

# VC

## GEAR TYPE FLOW METERS



**KRACHT**®  
FLUID TECHNOLOGY AND SYSTEMS

## Content

<b>General</b>		
Construction, function, general product characteristics, approvals		4
Electronic versions		5
<b>Technical data</b>		
General characteristics, nominal sizes, geometric tooth volumes, accuracy characteristics		6
Application examples		7
Specifications, electronic versions, measuring ranges		8
Resolutions, sound pressure levels, weights		9
Temperature compatibility of sealing elements and electronics		10 - 11
Pressure drop diagrams		12 - 18
<b>Type key</b>		19
<b>Electronics</b>		
Standard and high-temperature versions		20 - 21
Analogue versions		22 - 25
IO-Link versions		26 - 29
Encoder versions		30
Explosion-proof versions (ATEX/IECEX)		31
<b>Technical drawings – Flow meters</b>		
Spheroidal cast iron versions		32 - 33
Spheroidal cast iron versions / K3 specifications		34 - 35
Stainless steel versions		36 - 38
<b>Technical drawings – Connecting plates</b>		39 - 40

## General

### Construction

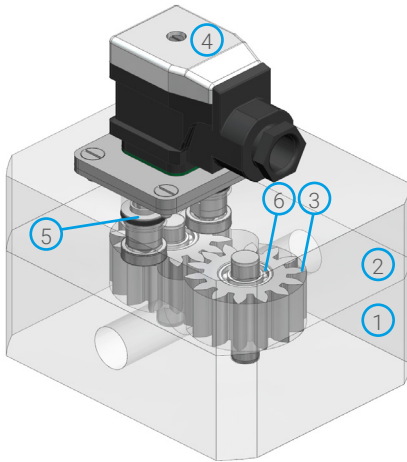

- 1 Housing
- 2 Cover
- 3 Gear
- 4 Plug
- 5 Sensor
- 6 Bearing

### General product characteristics

- High-precision measurements with excellent repeatability
- Encoder technology available with maximised measurement resolution
- IO-Link technology available
- Analogue technology available
- Explosion-proof versions ATEX/IECEX
- Wide measurement ranges with appropriate design sizes
- Application-optimised specification
- Low pressure drop
- Any flow direction
- Wide temperature range
- High working pressure
- Low noise emission
- Highly-dynamic measurements

### Function

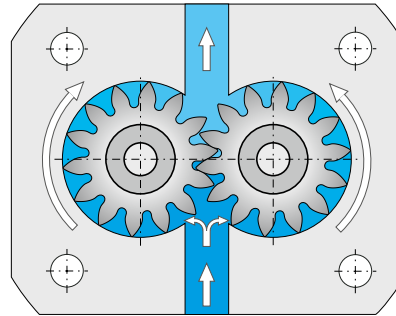

Consisting of two high-precision gears, the measuring unit is driven by the liquid flow based on the displacement principle. The gears run in an almost contactless manner in the measuring chamber. The bearing consists of ball and plain bearings.

Thanks to the measuring principle, there is no need for calming sections on the inlet and outlet side so that machines/plants can be designed to be more compact. All moving parts are lubricated by the measuring medium.

The gear movement is scanned in a contactless manner by the lid-mounted sensors. During the rotation of the measuring unit by one tooth pitch, a signal is generated per sensor that corresponds to the so-called geometric tooth volume. The dual-channel scanning facilitates a higher measuring resolution and detection of the direction of flow.

Alternatively available encoder specifications deliver maximal measurement resolution.

### Approvals

	Description	Country
	EU compliance – EMV – Pressure equipment – RoHS	European Union
	EAC EMV guideline	Eurasian Economic Community
	GOST metrology, measurement technology	Russia
	IO-Link	International

## General

### Electronic versions

#### Standard and high-temperature versions



These versions come with an integrated pre-amplifier which converts the pulses from the magnetic sensors into square-wave signals which are then computed by an electronics into specific measurement values.

#### IO-Link versions with internal calculation of measured values

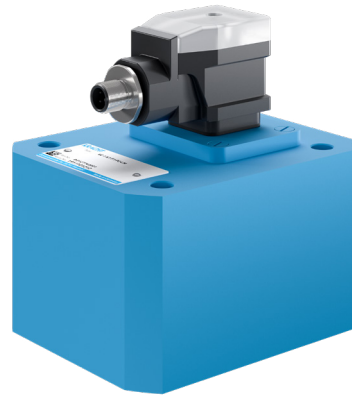

Flow meters with IO-Link technology are based on standard flow meters. Unlike standard versions which always send a square-wave signal to the electronics, IO-Link devices have the added capability of internally computing concrete measurement values. Therefore, these flow meters lend themselves for use in classic PLC and in IO-Link infrastructures.

#### Encoder versions with maximised measurement resolution



Compared to standard sensors, encoders are capable of generating significantly more pulses. This increases the measurement resolution many times over. Flow meters with encoders generate up to 2500 pulses per revolution and also detect the direction of flow. Like the standard versions, encoders supply square-wave signals to the evaluation electronics.

#### Analogue versions



Flow meters from the analogue series provide an analogue 4 ... 20 mA current signal that can be processed by many controllers and measuring devices. The analogue signal is used to determine the flow rate. In addition, devices with two sensors are able to transmit the flow direction via an additional digital signal.

#### Other versions

Alternatively, high-temperature Plus and low-temperature versions with remote electronics are available, designed for extreme temperature ranges. Flow meters compliant with ATEX/IECEX or ATEX/IECEX High-Temperature PLUS specifications are also available. For specialised applications, devices without a pre-amplifier are also offered.

## Technical data

### General characteristics

Type of connection	Plate mounting / Pipe connection
Mounting position	Any
Flow direction	Any
Maximum permissible pressure loss	16 bar
Viscosity	... 2 500 000 mm <sup>2</sup> /s

### Nominal sizes / Geometric tooth volumes

Nominal sizes	0.025	0.04	0.1	0.2	0.4	1	3	5	12	16
Geometric tooth volumes in cm <sup>3</sup>	0.025	0.040	0.100	0.245	0.400	1.036	3.000	5.222	12.000	16.000

### Accuracy characteristics

- The indicated measurement accuracy refers to the pulse volume, i.e. the percentage variance applies to the latest measurement value.
- The measurement accuracy is up to +/- 0.3% of the measured value by default.
- Repeatability is +/- 0.05% in stable conditions.
- The measurement accuracy tests performed can be traced to DAkkS (Deutsche Akkreditierungsstelle, German Accreditation Body).
- The measurement accuracy characteristics indicated by KRACHT is confirmed by DAkkS.
- A calibration is possible on request. The result of this calibration will be documented in the form of a measurement accuracy characteristic.

### Typical measurement accuracy characteristic

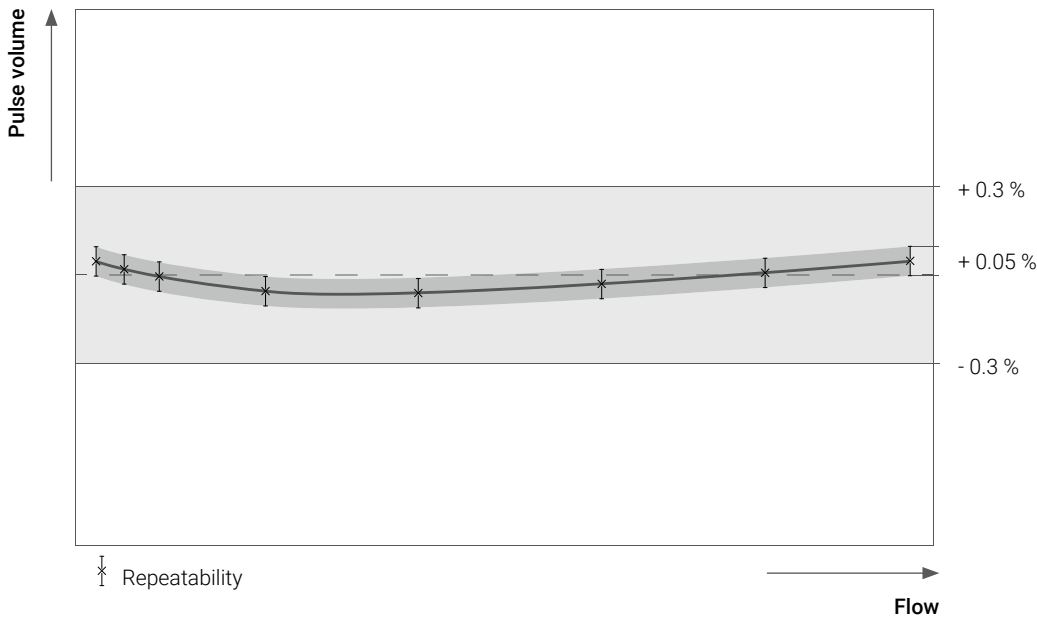

## Technical data

### Application examples

	- Bearings - Housing materials - Gear materials	Typical media	Typical media characteristics	Typical application of the flow/volume measurement
Specifications (type key ID for bearing and material)	K1 - Ball bearing - Spheroidal cast iron GJS-400 - Steel	Oil Braking fluid Diesel	Lubricating fluids Low to medium viscosity	Hydraulic systems Test bench construction Cylinder stroke measurement
	C1 - Ball bearing, high tolerance - Spheroidal cast iron GJS-400 - Steel	Gear oil	Lubricating fluids Medium viscosity	Oil filling (Metering systems)
	G1 - Carbide plain bearing - Spheroidal cast iron GJS-400 - Steel	Offset ink Polyol Isocyanate Glue Resin Silicone	Lubricating fluids Medium to high viscosity	Consumption measuring (Printing machines)
	G2 - Carbide plain bearing - Stainless steel - Stainless steel	Polyol Isocyanate Glue Resin Silicone	Poor lubricating fluids Medium to high viscosity	Ratio control (2-Component systems)
	K2 - Ball bearing - Stainless steel - Stainless steel	Clear varnish Cavity sealing wax	Lubricating fluids Low to medium viscosity	Dosing control (Paint-spray lines) Test bench construction
	H2 - Hybrid ball bearing - Stainless steel - Stainless steel	Urea (adBlue) Solvents Petrol	Poor lubricating fluids Low viscosity	Flow measurement (Paint-spray lines) Test bench construction Dosing
	K3 - Ball bearing - Spheroidal cast iron GJS-600 - Steel	Oil Braking fluid Diesel	Lubricating fluids Low viscosity	Applications of up to 480 bar for nominal sizes 3, 5, 12 and 16
	K4 - Ball bearing - Aluminium - Stainless steel	Oil Diesel Water	Low viscosity	Flow measurement

## Technical data

### Specifications

Specifications (type key ID for bearing and material)	K1	K2	G1	G2	C1	H2	K3	K4
Bearings	ball bearing	ball bearing	carbide plain bearing	carbide plain bearing	ball bearing (high clearances)	hybrid ball bearing	ball bearing	ball bearing
Housing materials	spheroidal cast iron GJS-400-15	stainless steel 1.4404	spheroidal cast iron GJS-400-15	stainless steel 1.4404	spheroidal cast iron GJS-400-15	stainless steel 1.4404	spheroidal cast iron GJS-600	aluminium 3.2315
Gear materials	steel 1.7131	stainless steel 1.4462	steel 1.7131	stainless steel 1.4462	steel 1.7131	stainless steel 1.4462	steel 1.7131	stainless steel 1.4462
Types of connection*	P	P / R	P	P / R	P	P / R	P	R
Permissible particle sizes in pumped medium	20 µm	20 µm	30 µm	30 µm	30 µm	20 µm	20 µm	20 µm
Media temperatures** in °C	-40 ... 210	-60 ... 210	-40 ... 80	-40 ... 80	-40 ... 210	-40 ... 210	-40 ... 210	-10 ... 80
Maximum pressures in bar								
0.025 · 0.04 · 0.1 · 0.2 · 0.4 · 1 · 12 · 16	480	480	480	480	480	480	480	200
3 · 5	350	350	350	350	350	-	480	-

\* Plate mounting (P) / Pipe connection (R)

\*\* See also the section "Technical data – Selection guide"

### Electronic versions

		Standard	High-temperature	ATEX/IECEX	IO-Link	Analogue	Encoder	High-temperature PLUS	ATEX/IECEX High-temperature PLUS	Low-temperature
Integrated electronics	Standard	•	•	•	•	•	•	•	•	•
	High-temperature	•	•	-	-	•	•	•	•	-
	ATEX/IECEX	•	•	•	•	•	•	•	•	•
	IO-Link	•	•	•	•	•	•	•	•	•
	Analogue	•	•	•	•	•	•	•	•	•
Remote electronics	Encoder	•	-	•	-	-	-	-	-	-
	High-temperature PLUS	•	•	-	-	-	•	•	-	-
	ATEX/IECEX High-temperature PLUS	•	•	-	-	-	•	•	-	-
	Low-temperature	-	•	-	-	-	-	-	-	-

### Measuring ranges

Nominal sizes	Starting points in l/min	Measuring ranges in l/min							
		0.008 ... 2	0.008 ... 2	-	0.02 ... 2	-	0.008 ... 2	-	-
0.025	0.001	0.008 ... 2	0.008 ... 2	-	0.02 ... 2	-	0.008 ... 2	-	-
0.04	0.004	0.02 ... 4	0.02 ... 4	-	-	-	0.02 ... 4	-	-
0.1	0.008	0.04 ... 8	0.04 ... 8	0.04 ... 8	0.04 ... 8	-	0.04 ... 8	-	-
0.2	0.01	0.16 ... 16	0.16 ... 16	0.16 ... 16	0.16 ... 16	0.16 ... 16	0.16 ... 16	-	0.2 ... 12
0.4	0.01	0.2 ... 40	-	0.2 ... 30	0.2 ... 30	-	-	-	-
1	0.02	0.4 ... 80	0.4 ... 80	0.3 ... 60	0.3 ... 60	0.4 ... 80	0.4 ... 80	-	-
3	0.03	0.6 ... 160	0.6 ... 160	0.6 ... 100	0.6 ... 100	0.6 ... 160	-	0.6 ... 160	-
5	0.04	1 ... 250	1 ... 250	1 ... 160	1 ... 160	1 ... 250	-	1 ... 250	-
12	0.1	-	-	-	-	-	-	2 ... 600	-
16	0.2	-	-	-	-	-	-	3 ... 700	-

## Technical data

### Resolution standard, IO-Link and analogue versions

Nominal sizes	0.025	0.04	0.1	0.2	0.4	1	3	5	12	16
Resolutions in pulse/l*	40 000.00	25 000.00	10 000.00	4 081.63	2 500.00	965.25	333.33	191.50	83.33	62.50

\* Resolution can be quadrupled by using both measurement channels (see the section "Electronics – Signal characteristics").

### Resolution encoder versions

Nominal sizes	Sensor resolutions*	Pulse volumes	Resolutions	Measured value resolutions 4-fold**	Max. pulse frequencies
	in pulse/rev	in cm <sup>3</sup> /pulse	in pulse/l	in pulse/l	in Hz
0.04	512	0.001484	673 684	2 694 737	44 912
	2 500	0.000304	3 289 474	13 157 896	219 298
0.2	512	0.006699	149 271	597 084	39 806
	2 500	0.001372	728 863	2 915 452	194 363
1	512	0.028328	35 301	141 204	47 067
	2 500	0.005802	172 366	689 464	229 822

\* More sensor resolutions available on request

\*\* Resolution with both measuring channels and 4-fold evaluation

### Sound pressure levels

Nominal sizes	0.025	0.04	0.1	0.2	0.4	1	3	5	12	16
Sound pressure levels in dB (A)	≤ 60	≤ 60	≤ 60	≤ 60	≤ 70	≤ 70	≤ 70	≤ 72	≤ 80	≤ 80

### Weights

		Nominal sizes									
		0.025	0.04	0.1	0.2	0.4	1	3	5	12	16
Spheroidal cast iron versions	Versions with integrated electronics	1.8	2.0	2.5	2.0	3.7	5.2	9.0	13.0	-	-
	Versions with separate electronics	1.8	2.0	2.3	2.0	3.7	5.2	9.0	13.0	-	-
	Encoder versions	-	2.0	-	2.0	-	5.4	-	-	-	-
	Versions in K3 specification	-	-	-	-	-	-	16.3	18.9	53.5	57.4
Stainless steel versions	All versions	3.0	3.0	3.0	3.1	4.8	7.0	15.9	18.7	-	-
Weights in kg											

## Technical data

### Temperature compatibility of sealing elements and electronics

Versions with integrated electronic (Hirschmann / IO-Link / Analogue / Encoder)

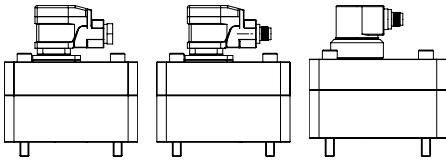

Electronic versions		Standard	High-temperature	ATEX/IECEX	IO-Link	Without pre-amplifier	Encoder (only K1/G1)	Analogue	
Type key ID		S	H	X	L	V	E	A	
<b>Medium temperatures in °C</b>									
Sealing materials	FKM	-40 ... 120	-40 ... 150	-15 ... 80	-40 ... 80	-40 ... 120	-20 ... 80	-40 ... 80	
	EPDM			-30 ... 80					
	FEP	-15 ... 120	-15 ... 150	-30 ... 80	-15 ... 120	-15 ... 80	-15 ... 80		
	FFKM			-15 ... 80					
<b>Ambient temperatures in °C</b>									
VC versions	Standard	-40 ... 80							
	IO-Link	-40 ... 50 (higher temperatures on request)							
	ATEX/IECEX	FKM	-15 ... 60						
		EPDM	-30 ... 60						
FEP		-30 ... 60							
FFKM		-15 ... 60							
Analogue	-40 ... 60 for supply voltages > 15 V -40 ... 80 for supply voltages < 15 V								

Versions with remote electronic

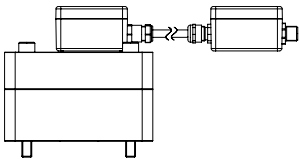

Electronic versions		High-temperature PLUS	ATEX/IECEX High-temperature PLUS	Low-temperature
Type key ID		K	KX	T
<b>Medium temperatures in °C</b>				
Sealing materials	FKM	-		
	EPDM	-		
	FEP	-40 ... 210	-30 ... 180	-
	FFKM	-15 ... 210	-15 ... 200	-
	FVMQ	-		-60 ... 200
<b>Ambient temperatures in °C</b>				
VC versions	Standard	-60 ... 150 for VC -40 ... 80 for remote electronic		
	ATEX/IECEX	FKM	-15 ... 60	
		EPDM	-30 ... 60	
		FEP	-30 ... 60	
		FFKM	-15 ... 60	

## Technical data

### Selection guide

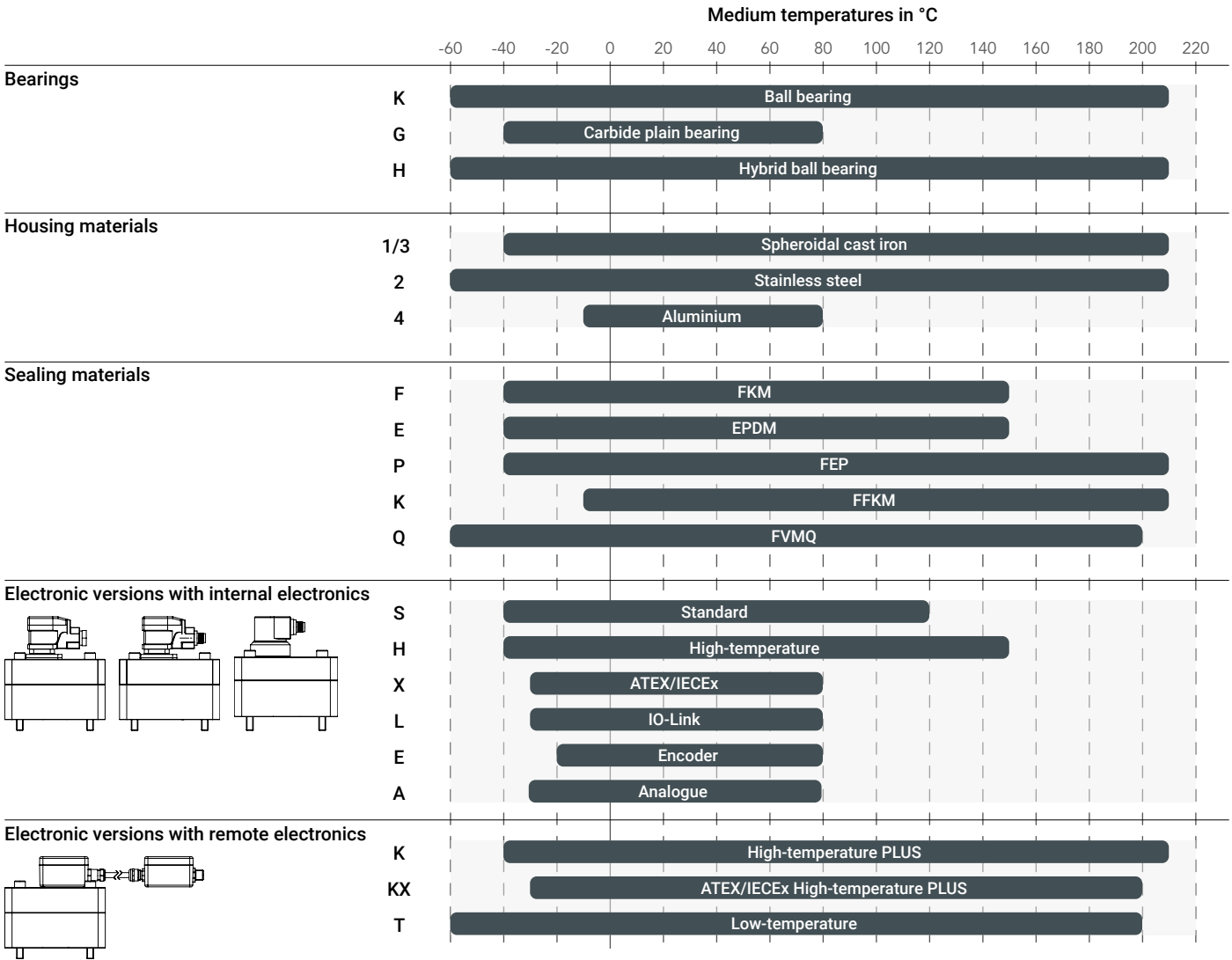

### Example: determination of temperature range

**VC 1 K 1 F 1 P 2 S H**

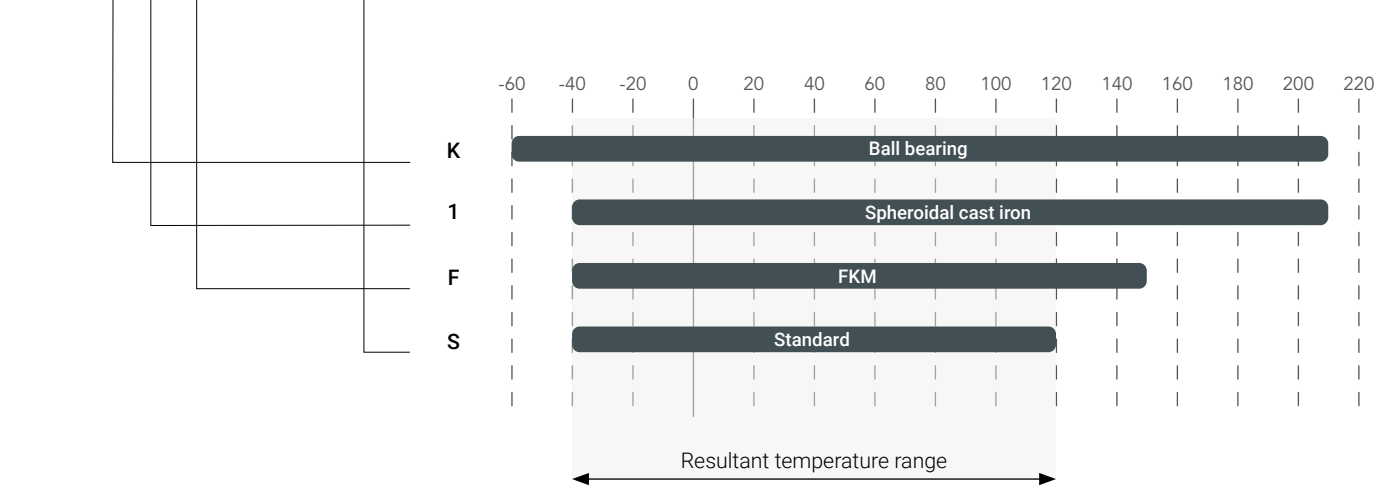

**Technical data**

**Pressure drop diagrams – Ball-bearing versions / Parameter: Viscosities in mm<sup>2</sup>/s**

**VC 0.025**

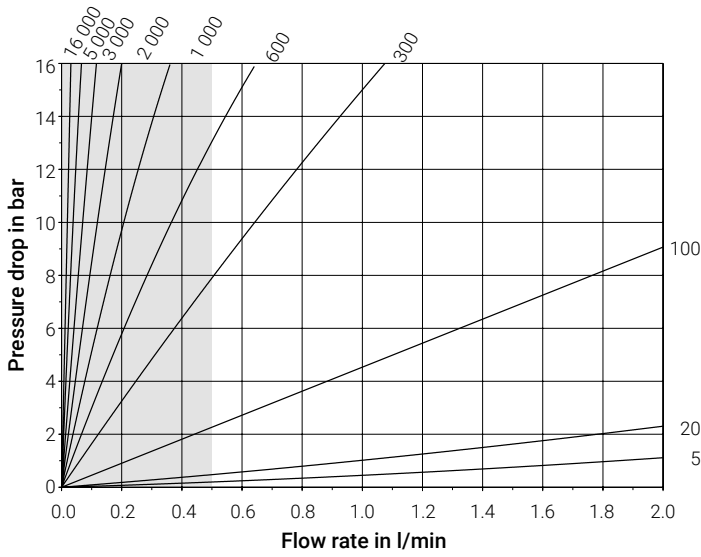

**VC 0.025 (section)**

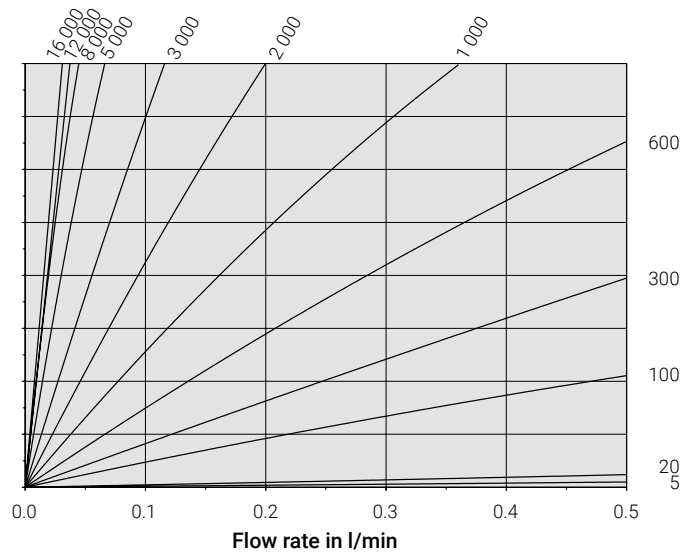

**VC 0.04**

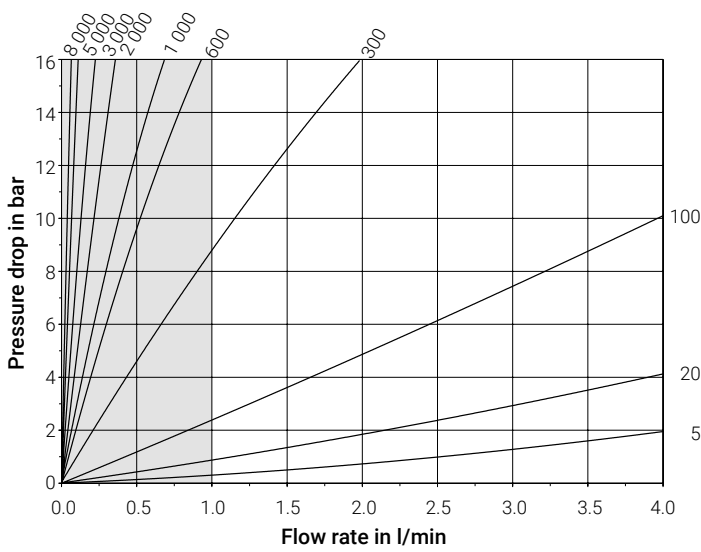

**VC 0.04 (section)**

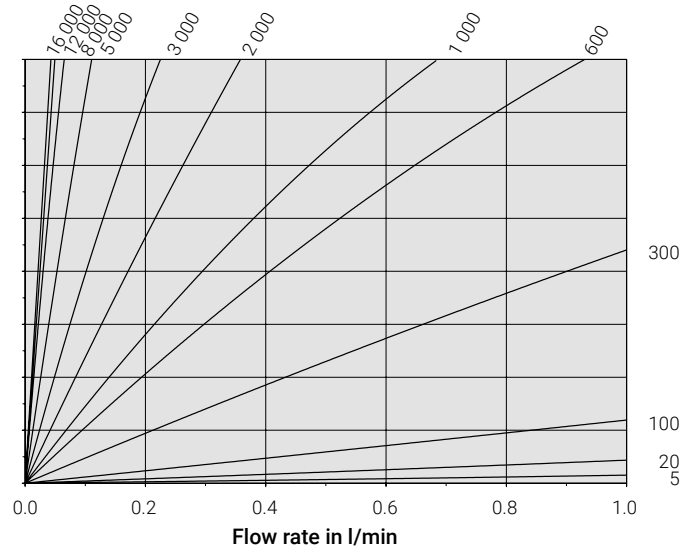

**VC 0.1**

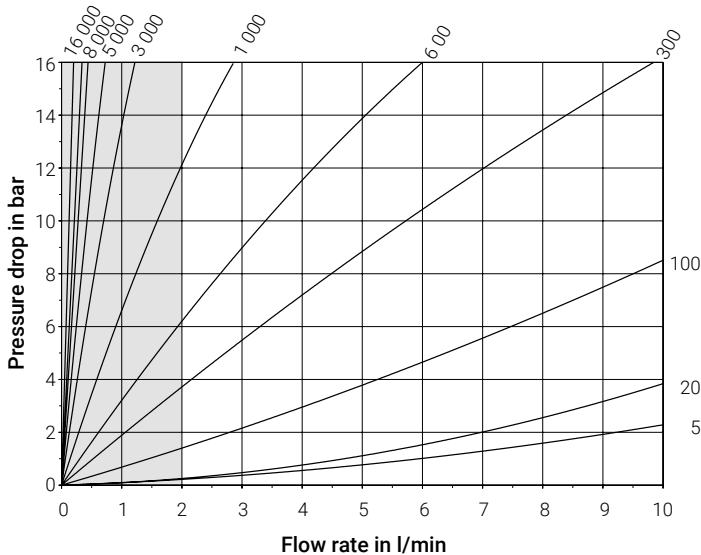

**VC 0.1 (section)**

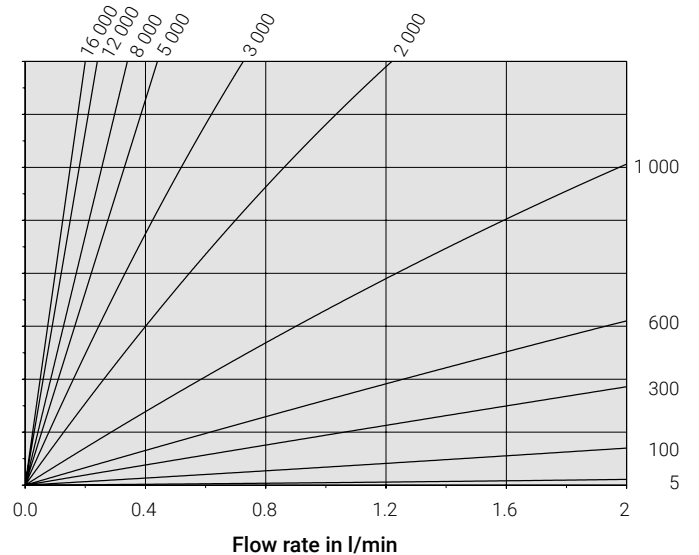

Technical data

Pressure drop diagrams – Ball-bearing versions / Parameter: Viscosities in mm<sup>2</sup>/s

VC 0.2

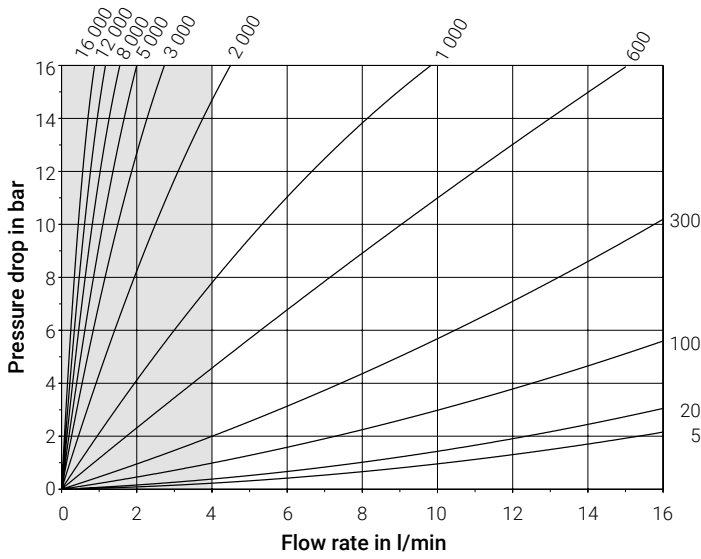

VC 0.2 (section)

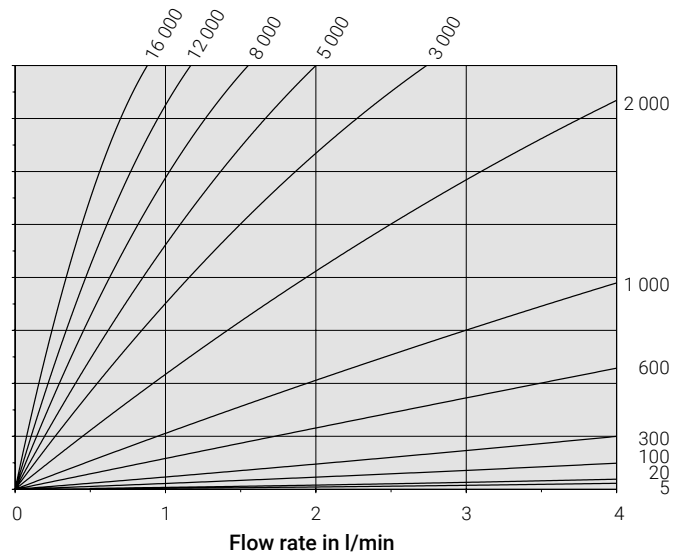

VC 0.4

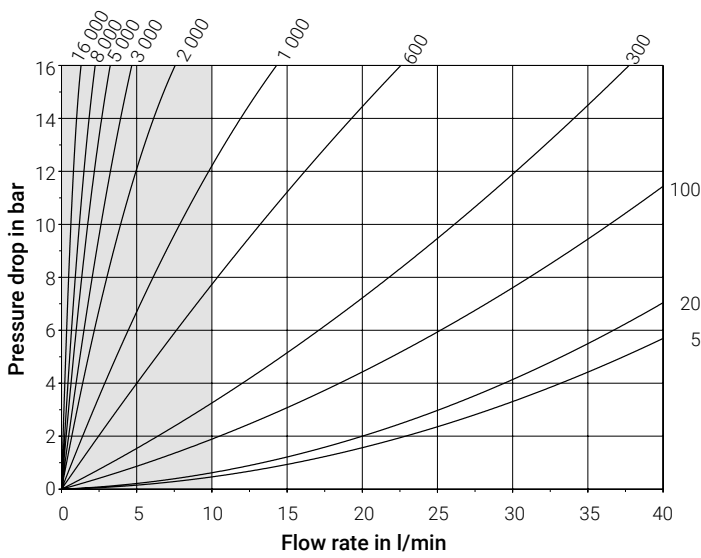

VC 0.4 (section)

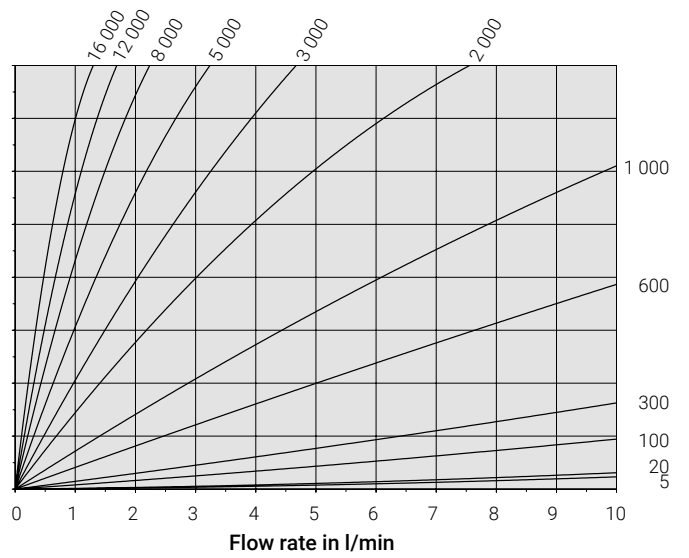

VC 1

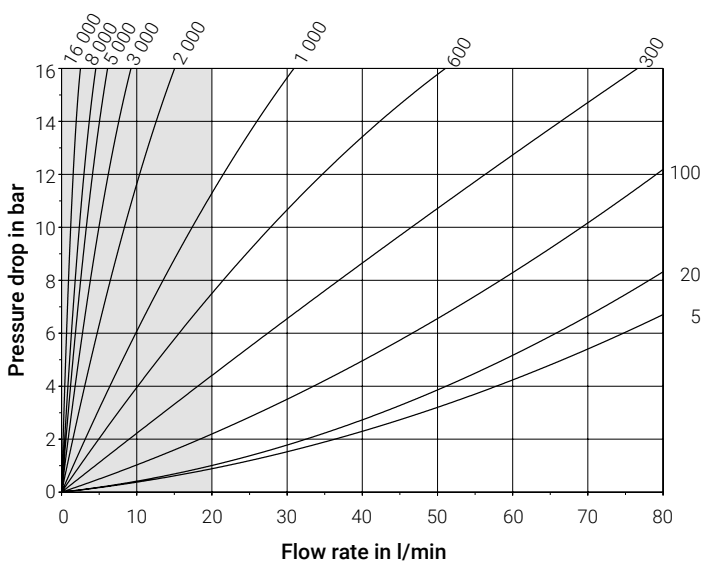

VC 1 (section)

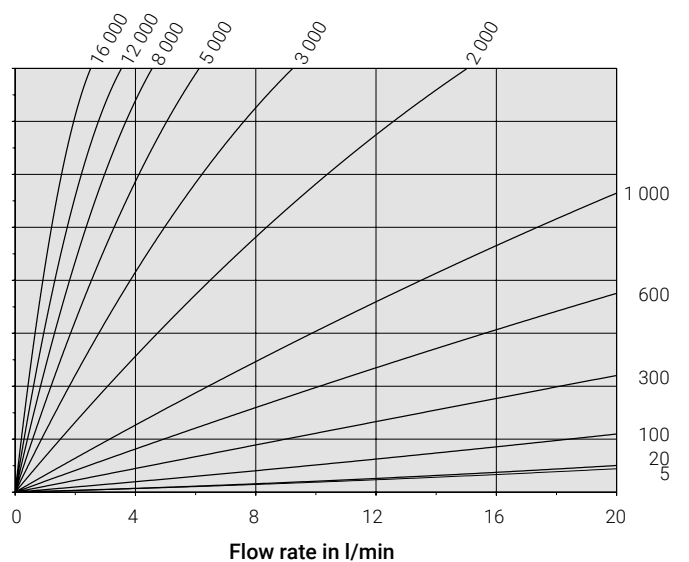

**Technical data**

**Pressure drop diagrams – Ball-bearing versions / Parameter: Viscosities in mm<sup>2</sup>/s**

**VC 3**

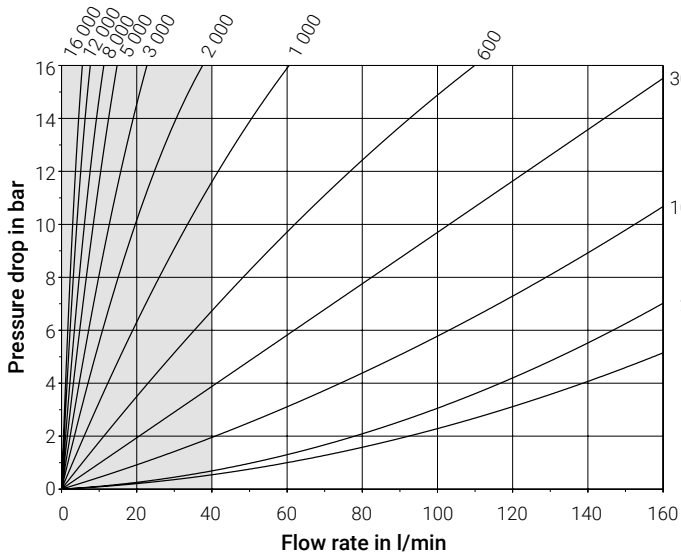

**VC 3 (section)**

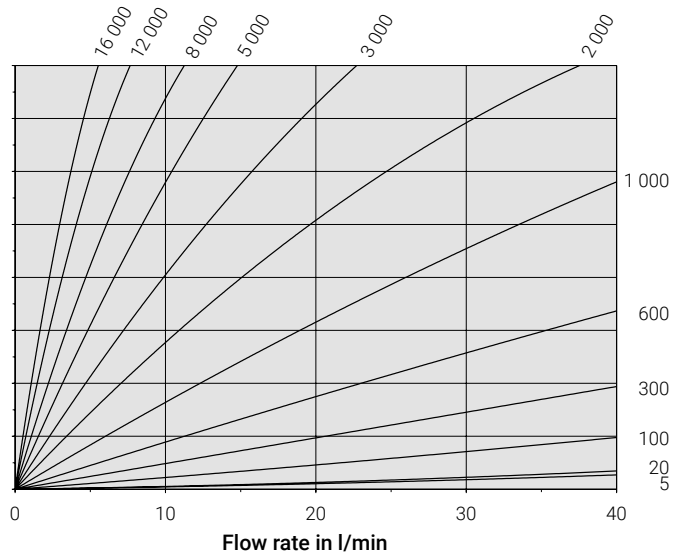

**VC 5**

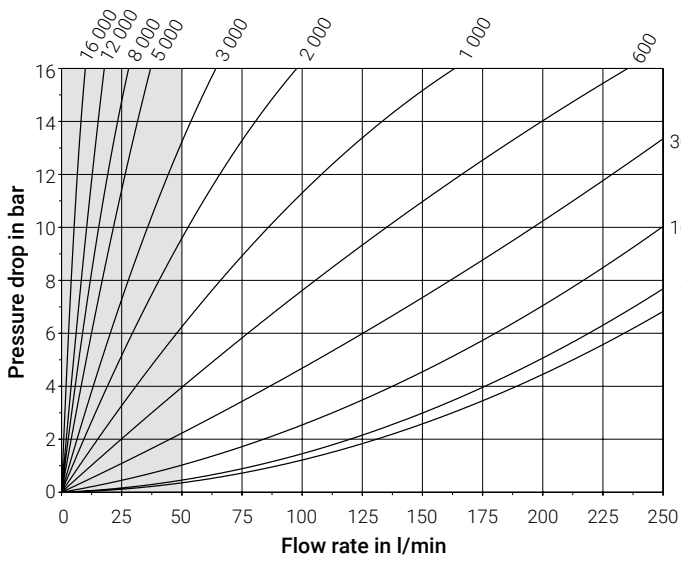

**VC 5 (section)**

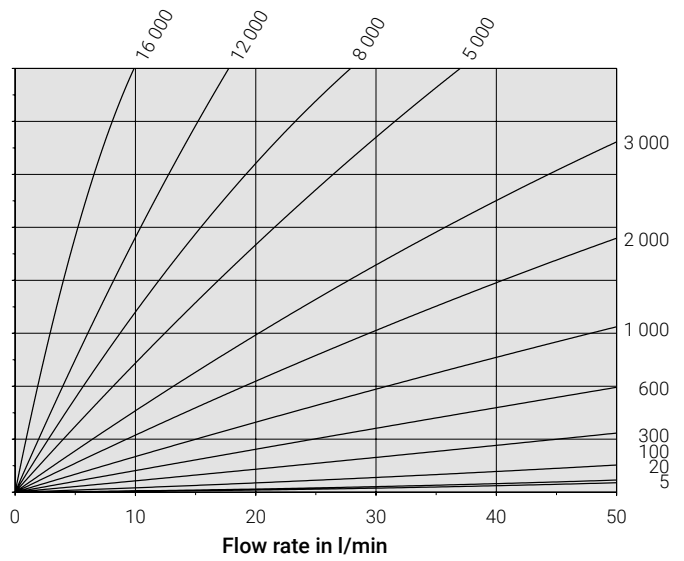

**VC 12**

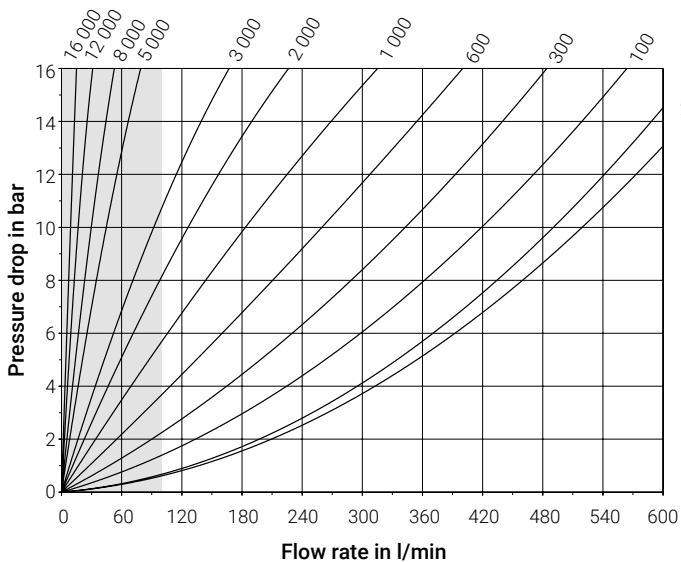

**VC 12 (section)**

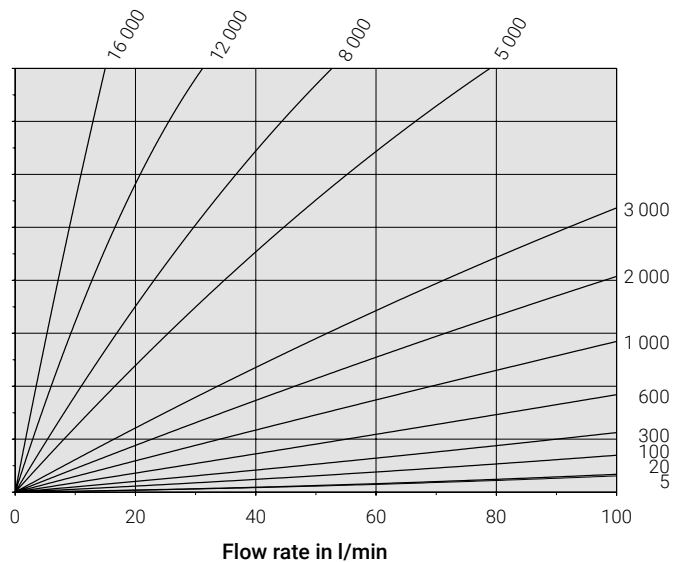

Technical data

Pressure drop diagrams – Ball-bearing versions / Parameter: Viscosities in mm<sup>2</sup>/s

VC 16

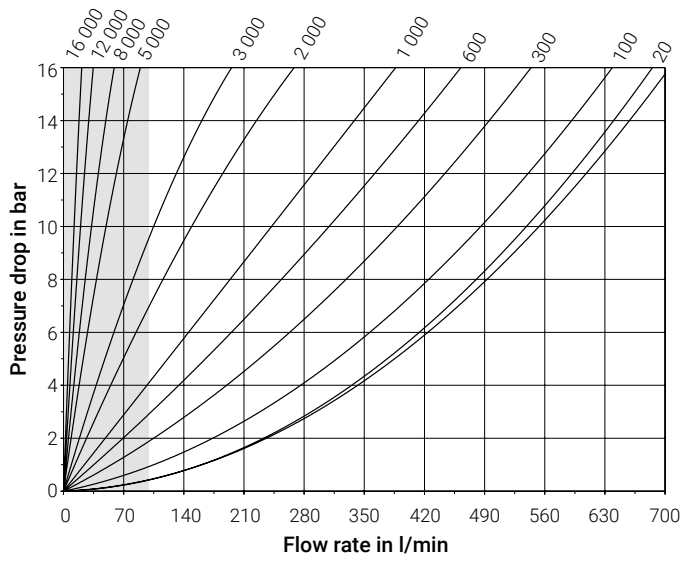

VC 16 (section)

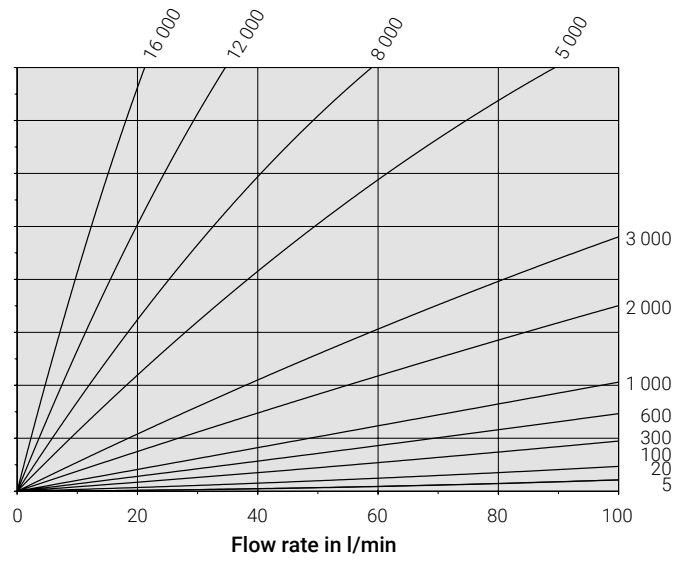

**Technical data**

**Pressure drop diagrams – Plain-bearing versions / Parameter: Viscosities in mm<sup>2</sup>/s**

**VC 0.025**

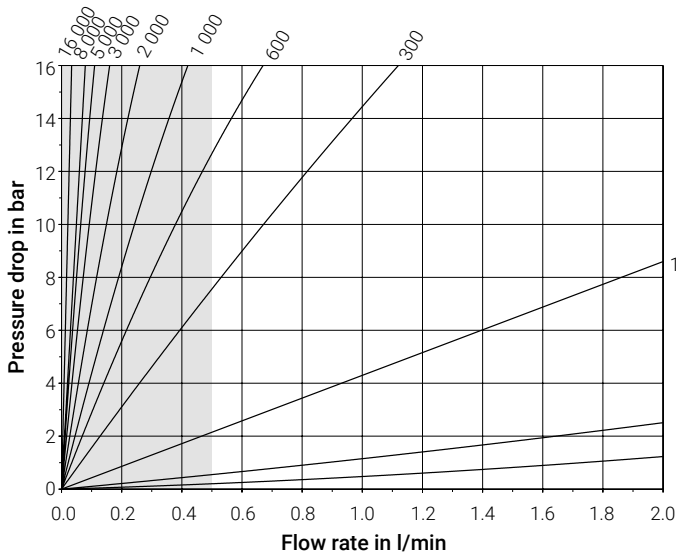

**VC 0.025 (section)**

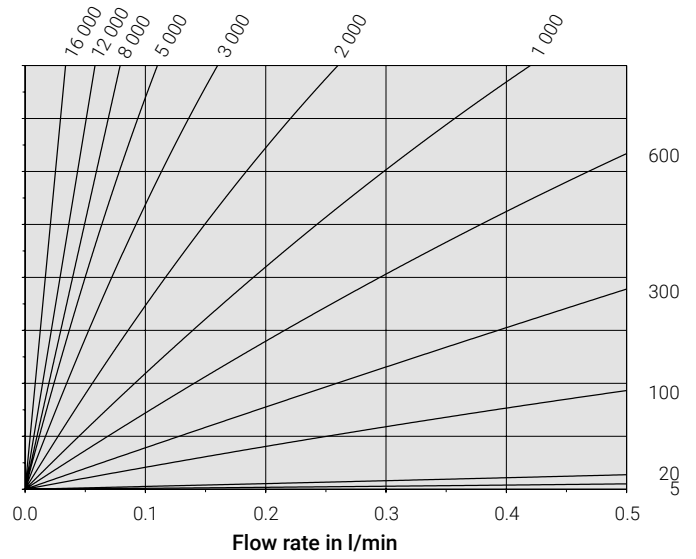

**VC 0.1**

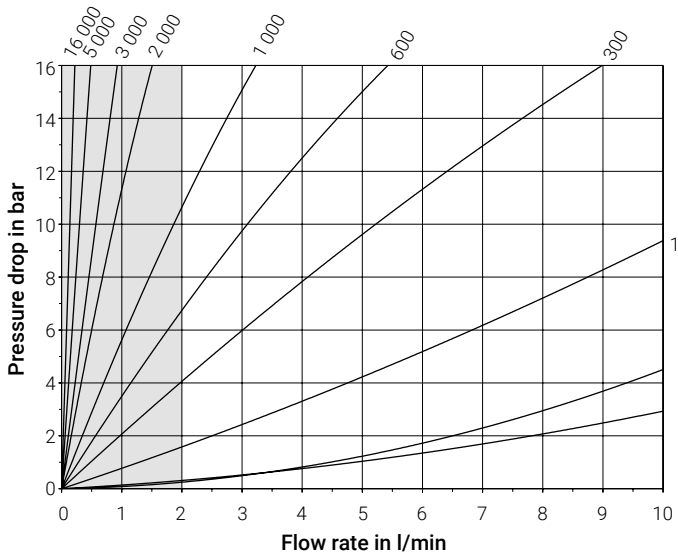

**VC 0.1 (section)**

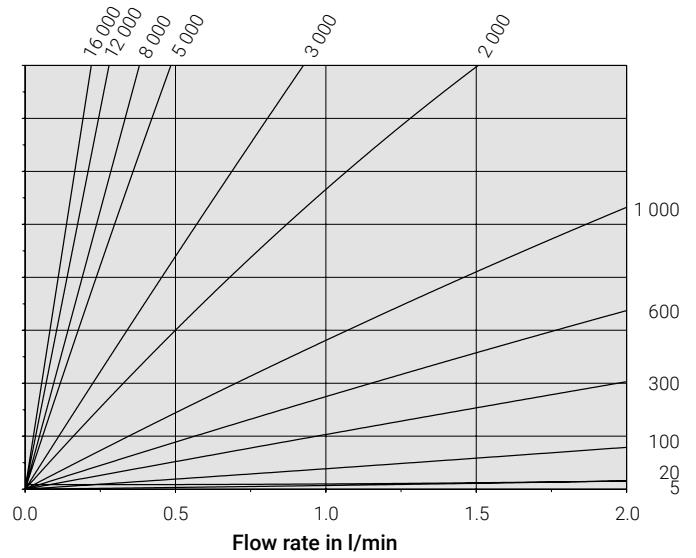

**VC 0.2**

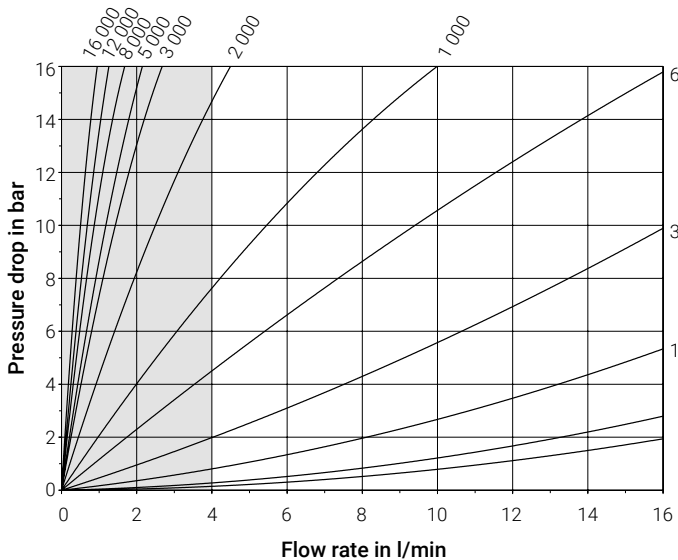

**VC 0.2 (section)**

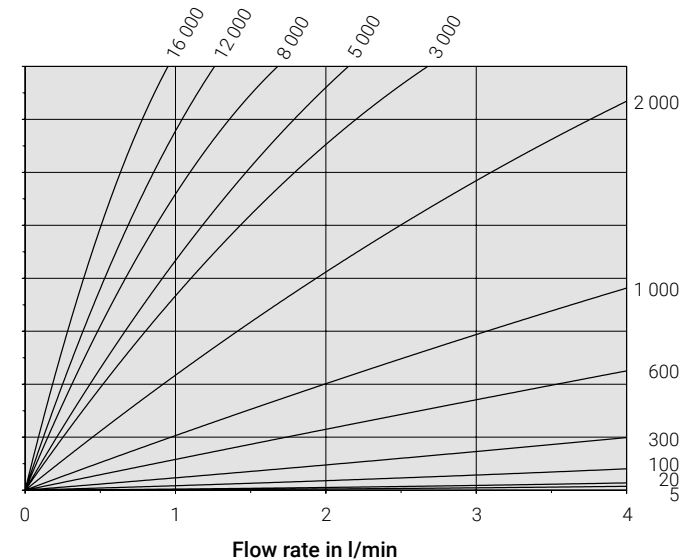

Technical data

Pressure drop diagrams – Plain-bearing versions / Parameter: Viscosities in mm<sup>2</sup>/s

VC 0.4

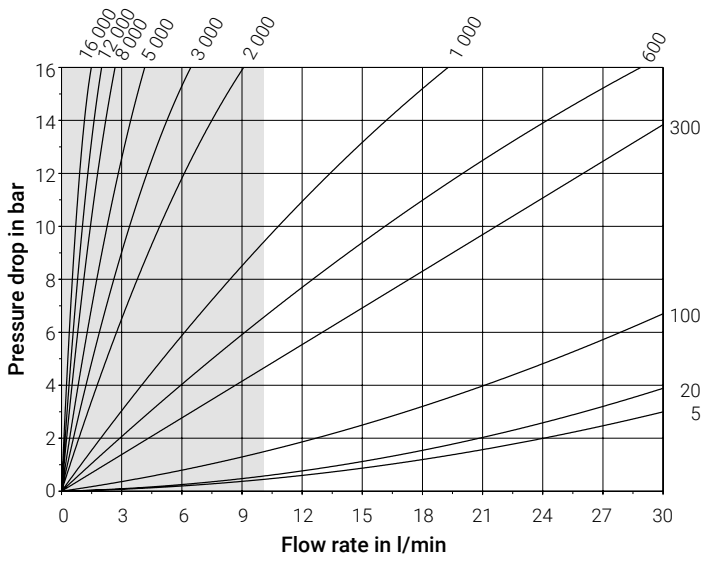

VC 0.4 (section)

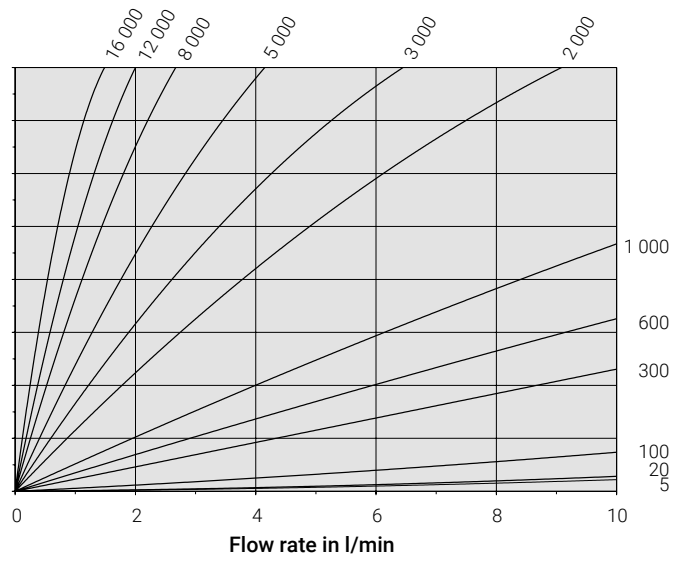

VC 1

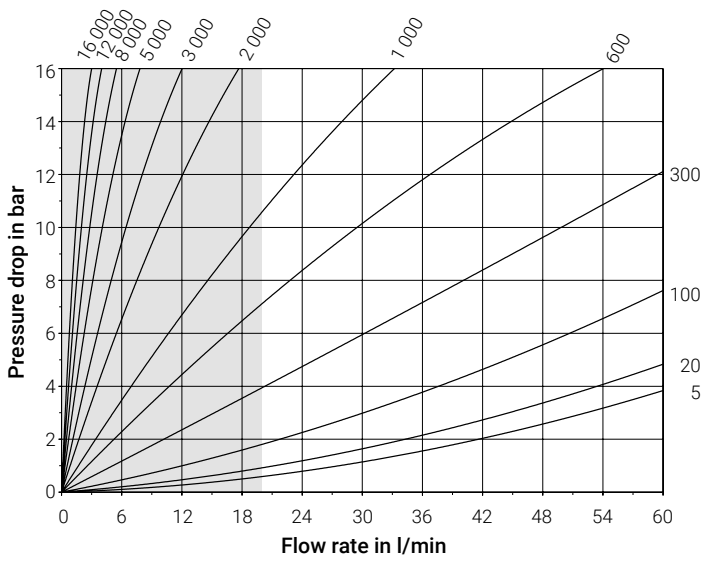

VC 1 (section)

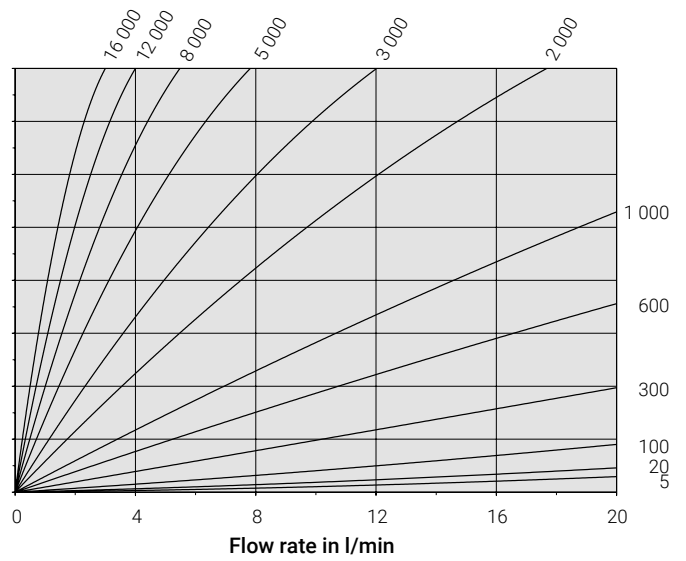

VC 3

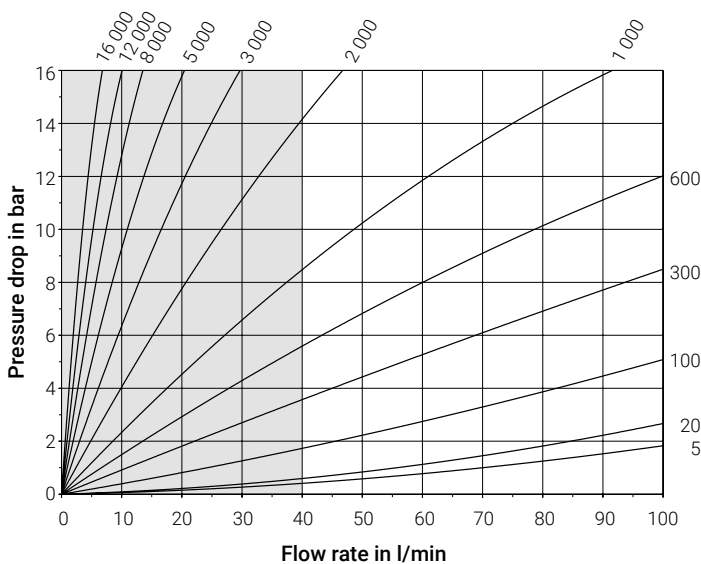

VC 3 (section)

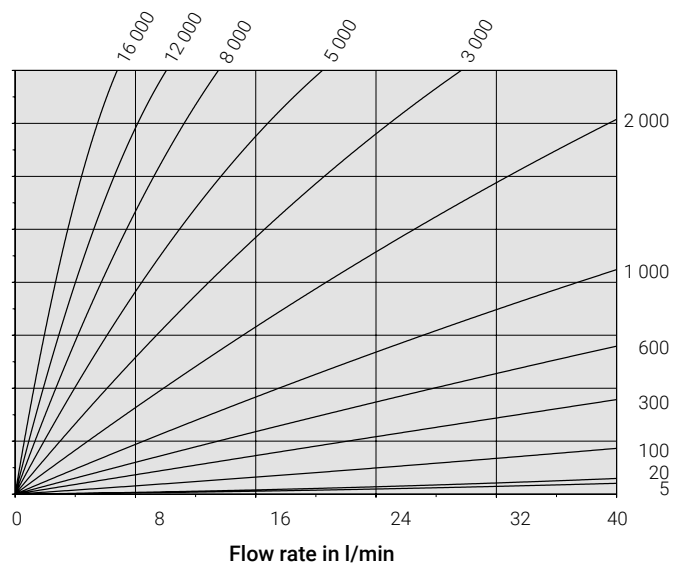

**Technical data**

**Pressure drop diagrams – Plain-bearing versions / Parameter: Viscosities in mm<sup>2</sup>/s**

**VC 5**

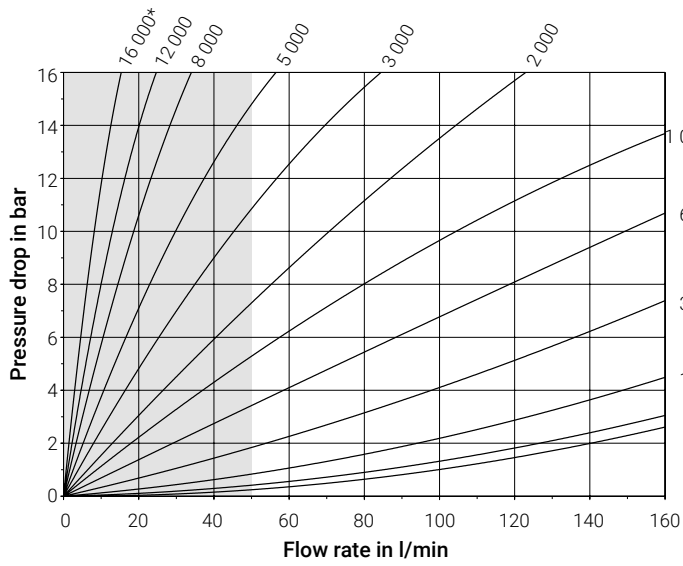

**VC 5 (section)**

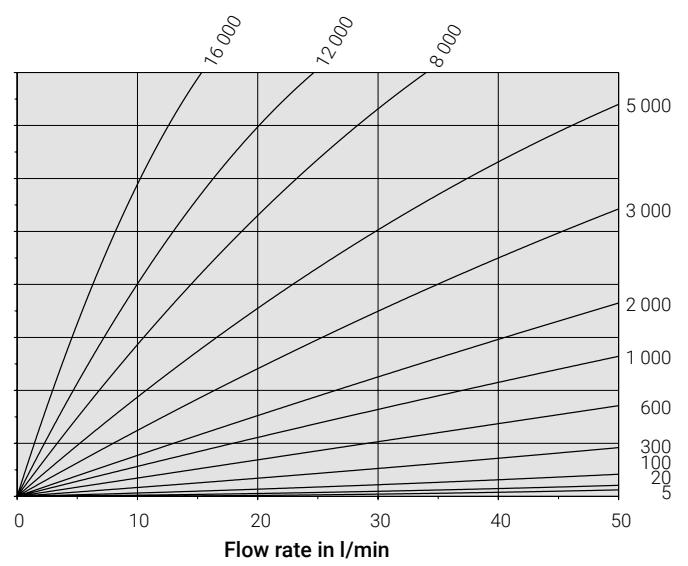

## Type key

<b>VC</b>	<b>1</b>	<b>K</b>	<b>1</b>	<b>F</b>	<b>1</b>	<b>P</b>	<b>2</b>	<b>S</b>		<b>H</b>
1	2	3	4	5	6	7	8	9	10	11

1 Product	
<b>VC</b>	Gear type flow meter

2 Nominal sizes	
0.025 · 0.04 · 0.1 · 0.2 · 0.4 · 1 · 3 · 5 · 12 · 16	

3 Bearings		Nominal sizes
<b>K</b>	Ball bearing	0.025 ... 16
<b>H</b>	Hybrid ball bearing	0.025 ... 0.2 · 1
<b>C</b>	Ball bearing: high tolerance	0.2 · 1 ... 5
<b>G</b>	Carbide plain bearing	0.025 · 0.1 ... 5

4 Materials		Nominal sizes
<b>1</b>	Housing: Spheroidal cast iron GJS-400, Gears: Steel	0.025 ... 5
<b>2</b>	Housing: Stainless steel, Gears: Stainless steel	0.025 ... 5
<b>3</b>	Housing: Spheroidal cast iron GJS-600, Gears: Steel	3 ... 16
<b>4</b>	Housing: Aluminium, Gears: Stainless steel	0.2

5 Sealings	
<b>F</b>	FKM
<b>E</b>	EPDM
<b>P</b>	FEP
<b>K</b>	FFKM
<b>Q</b>	FVMQ

6 Surfaces	
<b>1</b>	Coated
<b>3</b>	Uncoated

7 Connection types		Nominal sizes
<b>P</b>	Plate mounting	0.025 ... 16
<b>R</b>	Pipe connection	0.025 ... 5

8 Sensor technologies		Electronic versions	Nominal sizes
<b>1</b>	1 sensor	All except E	0.025 ... 16
<b>2</b>	2 sensors	All except E	0.025 ... 16
<b>3</b>	Without sensors	All except E	0.025 ... 16
<b>4</b>	2 sensors vibration-proof/condensation-proof	All except E	0.025 ... 16
<b>5</b>	Encoder	E	0.04 · 0.2 · 1

9 Electronic versions (pre-amplifier)		Electrical connections	Nominal sizes
<b>S</b>	Standard	H · M · C	0.025 ... 16
<b>H</b>	High-temperature	H · M	0.025 ... 16
<b>K</b>	High-temperature PLUS		0.025 ... 16
<b>T</b>	Low-temperature		0.025 ... 0.2 · 1 ... 5
<b>X</b>	ATEX/IECEx (isolating switching amplifier to be ordered separately)	H	0.025 ... 16
<b>KX</b>	ATEX/IECEx High-temperature PLUS	V	0.025 ... 16
<b>L</b>	IO-Link	M	0.025 ... 16
<b>V</b>	Without pre-amplifier	H	0.025 ... 16
<b>E</b>	Encoder	512 · 2500	0.04 · 0.2 · 1
<b>A</b>	Analogue	F	0.025 ... 16

10 Cable lengths	
	Without cable between flow meter and electronic
<b>2</b>	With 2 m cable
<b>5</b>	With 5 m cable
<b>10</b>	With 10 m cable

11 Electrical connections (Connector and pre-amplifier case)		
<b>H</b>	Appliance socket (Hirschmann)	standard
<b>M</b>	Appliance socket (Hirschmann)	with M12x1, 4-pole connection
<b>F</b>	Appliance socket (Hirschmann)	with M12x1, 5-pole connection
<b>K</b>	Aluminium connection box	with M12x1, 4-pole connection
<b>C</b>	Aluminium connection box	with Cannon plug KPTC
<b>E</b>	Aluminium connection box	with M12x1, 4-pole connection, external electronics can be disconnected
<b>V</b>	Without	
<b>512</b>	Encoder with 512 pulse/rev	with M12x1, 4-pole connection
<b>2 500</b>	Encoder with 2 500 pulse/rev	with M12x1, 4-pole connection

## Electronics

### Standard and high-temperature versions

#### General

The pre-amplifier generated square-wave signal enables application specific resolutions. Standard resolution means that the electronics will process one pulse from a channel/sensor per periodic time (a rising edge on channel 1 corresponds to a state change from low to high). The 4-fold evaluation, on the other hand, utilises the maximum number of state changes per period and enables a resolution four times higher than that of the standard evaluation. In this case, all characteristic features of the signal (rising and falling signal edges of both channels/sensors) are utilised during the evaluation. For devices with a single sensor, two state changes per periodic time are available, resulting in a 2-fold evaluation.

The duty cycle, the ratio between pulse and periodic time, is theoretically 50 % (1:1 ratio) in an ideal case – but may deviate by +/- 15 % in practice. For devices with two sensors, a tolerance of +/- 30° within the phase shifting of the two measurement channels is possible. Neither of these factors affects the resolution accuracy.

#### Electrical parameters

Number of measuring channels	1 or 2
Supply voltage	10 ... 30 V
Pulse amplitude	≥ 80 % of the supply voltage
Pulse form	Square
Duty cycle	50 % +/- 15 % (50 % corresponds to a duty factor 1:1)
Signal output	PNP / NPN / Push-Pull
Phase shifting (Devices with two sensors)	90 ° +/- 30 °
Maximum power requirement	0.9 W
Maximum output power per channel	0.3 W (short circuit-protected)
Protection rating	IP 65

#### LED configuration / behaviour

##### Flow meter with one sensor

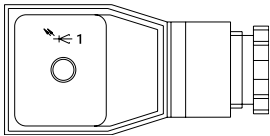

1	Signal transmitter channel 1 active	Red
---	-------------------------------------	-----

#### LED configuration / behaviour

##### Flow meter with two sensors

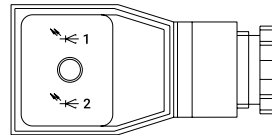

1	Signal transmitter channel 1 active	Red
2	Signal transmitter channel 2 active	Red

#### Pin configuration – Pre-amplifier

##### Flow meter with one sensor

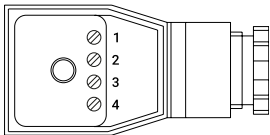

1	Supply voltage	Brown
2	Channel 1	Green
3	-	-
4	GND	White

#### Pin configuration – Pre-amplifier

##### Flow meter with two sensors

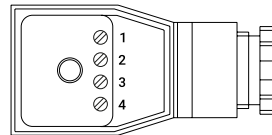

1	Supply voltage	Brown
2	Channel 1	Green
3	Channel 2	Yellow
4	GND	White

**Electronics**

**Standard and high-temperature versions**

**Signal behaviour**

**Flow meter with one sensor**

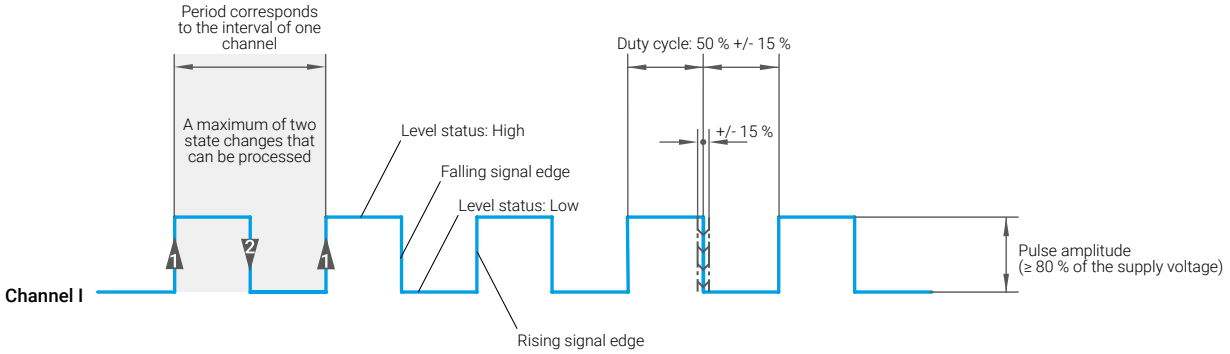

**Flow meter with two sensors**

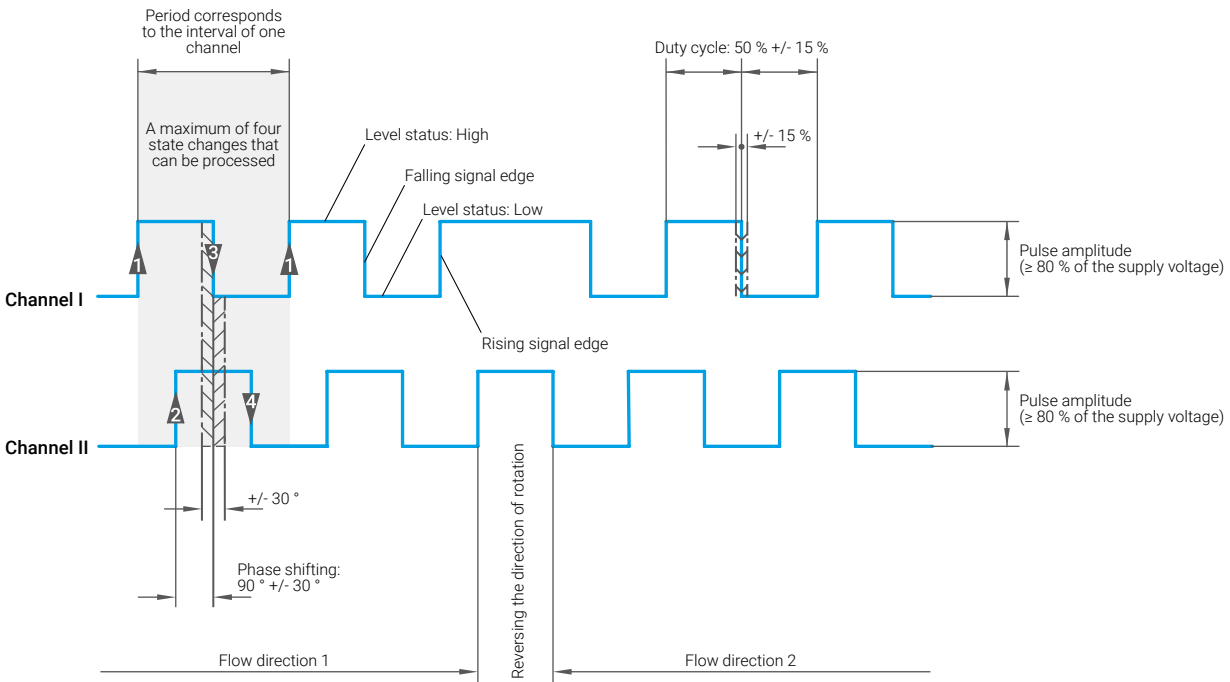

## Electronics

### Analogue versions

#### General

In addition to a digital signal indicating the direction of flow, analogue technology enables the provision of a 4 ... 20 mA current signal for determining the flow rate. A flow meter with two sensors and a digital input on the evaluation electronics are required for digital flow direction determination.

The 4 ... 20 mA range can be adapted to the application-specific measurement range. The analogue technology has been specially developed for standard analogue current inputs on controllers or measuring instruments.

#### Characteristics:

- Individualisation of the measuring range possible
- Universal application possibilities
- 16 bit resolution
- Cable break detection
- Display of flow rate and direction by proportional LED behaviour on the device

#### Firmware versions

Version	Date	Information
FW-V1.01	from 10.07.2024	First delivery status

#### LED configuration / behaviour

##### Flow meter with one sensor

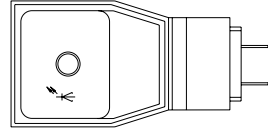

LED behaviour is proportional to the flow rate		
Green	Steady light	No measurable flow
Green/Red	Flashing	Flow rate within the measurement range
Red	Steady light	Maximum flow rate exceeded

#### LED configuration / behaviour

##### Flow meter with two sensors

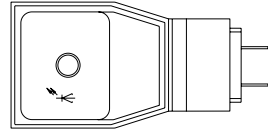

LED behaviour is proportional to the flow rate		
Blue	Steady light	Negative flow Maximum flow rate exceeded
Blue/Green	Flashing	Negative flow Flow rate within the measurement range
Green	Steady light	No measurable flow
Green/Red	Flashing	Positive flow Flow rate within the measurement range
Red	Steady light	Positive flow Maximum flow rate exceeded

#### Pole assignment – M12x1 circular connector / 5-pole

##### Flow meter with one or two sensors

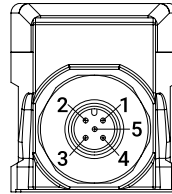

- 1 Supply voltage
- 2 Analogue output
- 3 GND
- 4 Digital output
- 5 Digital input

#### Wiring

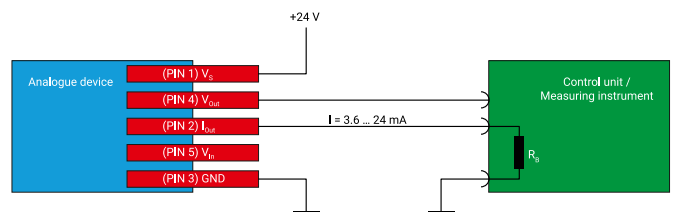

## Electronics

### Analogue versions

#### Load on the analogue output

If the analogue output is overloaded, the output current can no longer be driven by the available operating voltage. If there is a break in the cable, the resistance is too high and the electronics will indicate a value below 3.6 mA. If the load is too high, the output will be distorted, as the maximum flow rate can no longer be represented.

The following formula can be used for the calculation:

$$R_{B \max} = ((V_S - 4 \text{ V}) / 0.024 \text{ A}) - 40 \Omega$$

Example

Maximum load on the analogue output at 24 V:

$$\begin{aligned} R_{B \max} &= ((24 \text{ V} - 4 \text{ V}) / 0.024 \text{ A}) - 40 \Omega \\ &= (20 \text{ V} / 0.024 \text{ A}) - 40 \Omega \\ &= 833 \Omega - 40 \Omega \\ &= 793 \Omega \end{aligned}$$

$V_S$  Supply voltage (typically 24V DC)

$R_{B \max}$  Maximum resistance of the analogue current load

#### Electrical parameters

<b>Number of measuring channels</b>	1 or 2
<b>Supply voltage</b>	10 ... 30 V DC (Reverse polarity protection up to 30 V DC)
<b>Maximum load at the analog output</b>	793 $\Omega$ at 24 V DC
<b>Maximum current at the digital output</b>	100 mA (short-circuit-proof)
<b>Maximum power requirement</b>	1.4 W (without analogue and digital outputs)
<b>Output signals</b>	Analogue output 0 ... 24 mA (Measuring range from 4 ... 20 mA) Digital output High > Supply voltage - 3 V Low < 3 V
<b>Protection rating</b>	IP 65

## Electronics

### Analogue versions with one sensor

#### Interpretation of the signal behaviour

The 4 ... 20 mA range of the analogue signal is not restricted in the standard configuration and could therefore cover the entire measuring range of the flow meter. However, the signal can be assigned to an individual measuring range in accordance with the application requirements. In this example (actual flow rate is between 0 and 50 l/min), the range between 10 ... 40 l/min is relevant for the application, to which the 4 ... 20 mA signal range is proportionally assigned.

If the flow rate exceeds the defined maximum measurement value, the signal switches actively to 24 mA. Furthermore, a technical fault in the form of a broken wire or incorrect wiring can be detected. In this case, the electronics cannot function, which corresponds to a value of 0 mA at the control input. If the flow rate through the flow meter falls below the defined minimum measurement value, the signal switches actively to 3.6 mA. This provides the electronics with information that allows them to distinguish a flow rate below the minimum of the measurement range from a wire break or technical fault.

#### Electrical parameters

<b>Lower limit of the measuring range</b>	≈ 4 mA	= 10 l/min
<b>Upper limit of the measuring range</b>	≈ 20 mA	= 40 l/min
<b>Value below the lower limit of the measurement range</b>	≈ 3.6 mA	< 10 l/min
<b>Value above the upper limit of the measurement range</b>	≈ 24 mA	> 40 l/min
<b>Broken wire / Technical fault</b>	≈ 0 mA	
<b>Overload</b>	≈ > 0 mA or < 3.6 mA	

#### Value above the upper limit of the measurement range

When the maximum of the measuring range of 40 l/min is reached, the electronics output a current of 20 mA. If the maximum of the measuring range is exceeded, the output jumps from 20 mA to 24 mA and there is no longer a linear relationship between the flow rate and the analogue signal.

#### Value below the lower limit of the measurement range

When the minimum of the measuring range is 10 l/min, the electronics output a current of 4 mA. If the flow rate falls below the minimum of the measuring range, the output drops from 4 mA to 3.6 mA and there is no longer a linear relationship between the flow rate and the analogue signal.

#### Visual indication of the flow meter's behaviour

The flow rate is indicated visually via an RGB LED and can be seen directly on the device.

#### Example of actual flow rate 0 ... 50 l/min

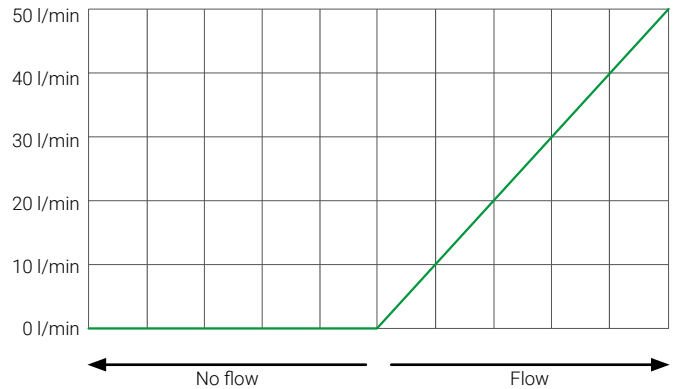

#### Analogue signal based on a defined measuring range of 10 ... 40 l/min

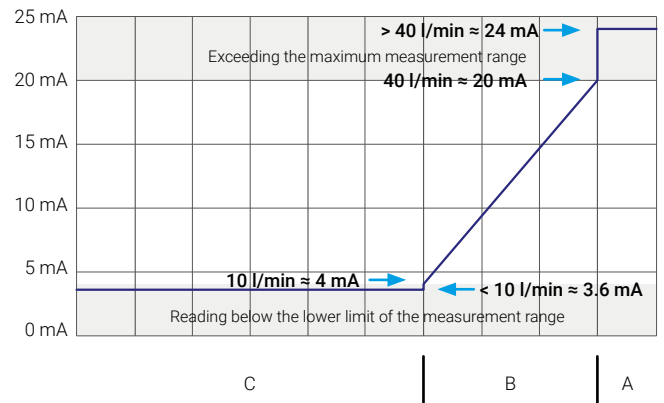

- A Maximum flow rate exceeded
- B Measurable flow range
- C Flow rate below minimum

#### LED behaviour



LED behaviour is proportional to the flow rate		
<b>Green</b>	Steady light	No measurable flow
<b>Green/Red</b>	Flashing	Flow rate within the measurement range
<b>Red</b>	Steady light	Maximum flow rate exceeded

## Electronics

### Analogue versions with two sensors

#### Interpretation of the signal behaviour

The 4 ... 20 mA range of the analogue signal is not restricted in the standard configuration and could therefore cover the entire measuring range of the flow meter. However, the signal can be assigned to an individual measuring range in accordance with the application requirements. In this example (actual flow rate is between 0 and 50 l/min), the range between 10 ... 40 l/min is relevant for the application, to which the 4 ... 20 mA signal range is proportionally assigned.

If the flow rate exceeds the defined maximum measurement value, the signal switches actively to 24 mA. Furthermore, a technical fault in the form of a broken wire or incorrect wiring can be detected. In this case, the electronics cannot function, which corresponds to a value of 0 mA at the control input. If the flow rate through the flow meter falls below the defined minimum measurement value, the signal switches actively to 3.6 mA. This provides the electronics with information that allows them to distinguish a flow rate below the minimum of the measurement range from a wire break or technical fault.

#### Electrical parameters

Lower limit of the measuring range	≈ 4 mA	= 10 l/min
Upper limit of the measuring range	≈ 20 mA	= 40 l/min
Value below the lower limit of the measurement range	≈ 3.6 mA	< 10 l/min
Value above the upper limit of the measurement range	≈ 24 mA	> 40 l/min
Broken wire / Technical fault	≈ 0 mA	
Overload	≈ > 0 mA or < 3.6 mA	

#### Value above the upper limit of the measurement range

When the maximum of the measuring range of 40 l/min is reached, the electronics output a current of 20 mA. If the maximum of the measuring range is exceeded, the output jumps from 20 mA to 24 mA and there is no longer a linear relationship between the flow rate and the analogue signal.

#### Value below the lower limit of the measurement range

When the minimum of the measuring range is 10 l/min, the electronics output a current of 4 mA. If the flow rate falls below the minimum of the measuring range, the output drops from 4 mA to 3.6 mA and there is no longer a linear relationship between the flow rate and the analogue signal.

#### Determining the direction of flow using the digital signal

- If flow passes through the meter in the forward direction, the digital signal is switched to the supply voltage.
- If flow passes through the meter in the reverse direction, the digital signal is held at 0 V.
- If no current flows through the meter, or if the current is less than the minimum of the measuring range, the direction signal is undefined and can assume either the high or low state.

#### Visual indication of the flow meter's behaviour

The flow rate is indicated visually via an RGB LED and can be seen directly on the device.

#### Example of actual flow rate 0 ... 50 l/min

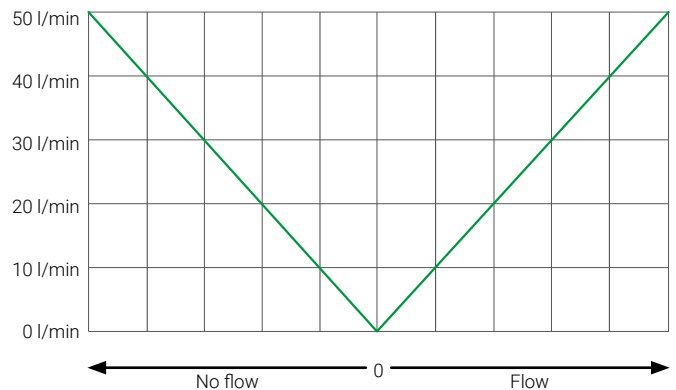

#### Analogue signal based on a defined measuring range of 10 ... 40 l/min

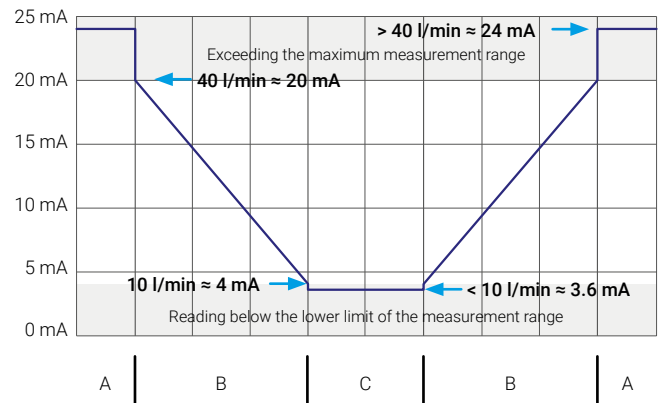

- A Maximum flow rate exceeded
- B Measurable flow range
- C Flow rate below minimum

#### Digital signal

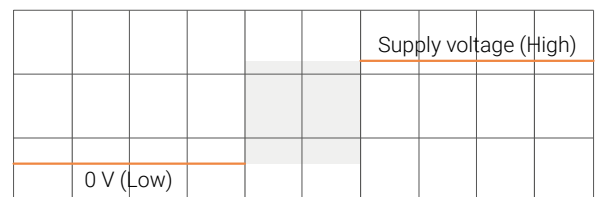

Below the minimum flow rate, the digital signal is undefined

#### LED behaviour



LED behaviour is proportional to the flow rate		
Blue	Steady light	Negative flow Maximum flow rate exceeded
Blue/ Green	Flashing	Negative flow Flow rate within the measurement range
Green	Steady light	No measurable flow
Green/ Red	Flashing	Positive flow Flow rate within the measurement range
Red	Steady light	Positive flow Maximum flow rate exceeded

## Electronics

### IO-LINK versions

#### General

Thanks to its international standardisation (IEC 61131-9), the IO-Link technology offers a point-to-point connectivity with continuous monitoring between any desired control layer and the IO-Link assembly. Handling and startup is made easy by the associated IODD file (IO Device Description) strongly simplified.

The IO-Link assembly directly delivers all measured values with units. In the preset SIO mode (standard input output), the volume counter gives squarewave signals if the IO-Link mode is not enabled by an IO-Link master. This guarantees downward compatibility of the IO-Link assembly with the standard square-wave signal.

The square-wave signal generated by the IO-Link module enables application specific resolutions. Standard resolution means that the electronics will process one pulse from a channel/sensor per periodic time (a rising edge on channel 1 corresponds to a state change from low to high). The 4-fold evaluation, on the other hand, utilises the maximum number of state changes per period and enables a resolution four times higher than that of the standard evaluation. In this case, all characteristic features of the signal (rising and falling signal edges of both channels/sensors) are utilised during the evaluation. For devices with a single sensor, two state changes per periodic time are available, resulting in a 2-fold evaluation.

The duty cycle, the ratio between pulse and periodic time, is theoretically 50 % (1:1 ratio) in an ideal case – but may deviate by +/- 15 % in practice. For devices with two sensors, a tolerance of +/- 30° within the phase shifting of the two measurement channels is possible. Neither of these factors affects the resolution accuracy.

#### Calibration of the pulse volume correction factor (Index 80)

If necessary, the pulse volume correction factor (variable „name“:  $V_{gz}$  factor) can be calibrated. Such calibration may be necessary due to variations in viscosity, temperature, or other external factors.

#### Calculation of the correction factor

Factor = Actual volume / PDOUT\_Volume

Example procedure:

1. Default  $V_{gz}$  factor = 1
2. Measure the test volume until the analysis unit displays 100 l ≈ PDOUT\_Volumen = 100 l
3. A verification measurement of the test volume using a calibrated measuring system gives an actual volume of 98 litres
4. Calculation of the correction factor: 98 l / 100 l = 0.98
5. Transmit the calculated factor to the IO-Link device
6. The actual volume then corresponds to PDOUT\_Volume

#### Calibration of the weight calculation (Index 81)

The weight of the fluid flow is calculated using the flow rate and density. The density is factory-set to 1 kg/l.

#### LED configuration / behaviour

##### Flow meter with one sensor

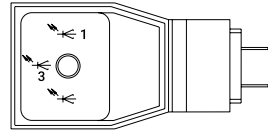

		IO-Link mode	SIO mode
1	Red	Signal transmitter channel 1 active	
3	Green	Flashing, IO-Link mode active	Steady light, SIO mode active

#### LED configuration / behaviour

##### Flow meter with two sensors

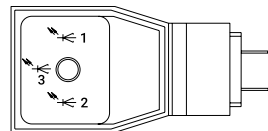

		IO-Link mode	SIO mode
1	Red	Signal transmitter channel 1 active	
2	Red	Signal transmitter channel 2 active	
3	Green	Flashing, IO-Link mode active	Steady light, SIO mode active

#### Pole assignment – M12x1 circular connector / 4-pole

In the SIO mode, the connector assignment for channel 1 or 2 influences the displayed direction of rotation of the measuring unit.

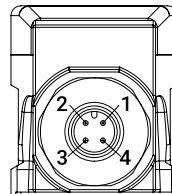

	IO-Link mode	SIO mode
1	Supply voltage	
2	I/Q	Channel 1
3	GND	
4	C/Q	Channel 2

According to IEC 61076-2-101 A-coded Port class A! Additional power supply not required.

#### Firmware versions and changes (Index 23)

Versions	Dates	Informations
<b>FW-V0.56</b>	First customer version	First delivery status
<b>FW-V0.58</b>	from 11.01.2022	Processing frequency extended
<b>FW-V1.03</b>	from 01.09.2023	Stack update to V1.1.3 Hardware redesign
<b>FW-V1.07</b>	from 16.12.2024	Adjustments of volume and weight output as Float32T value

## Electronics

### IO-Link versions

#### Communication of the assembly

SIO mode	Same output of the two square-wave signals as in standard pre-amplifier
IO-Link mode	Signal output as described in IO-Link according to the following units: Number of pulses, litres, dm <sup>3</sup> ...

#### Signal behaviour in SIO mode

##### Flow meter with one sensor

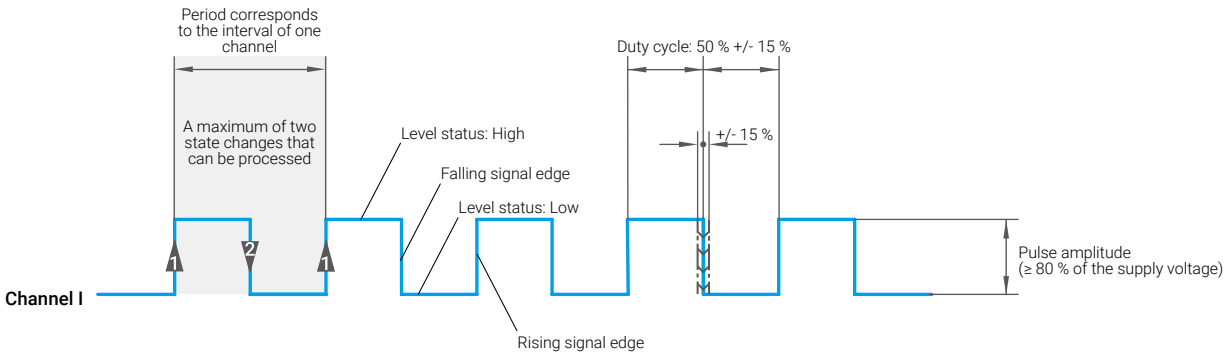

##### Flow meter with two sensors

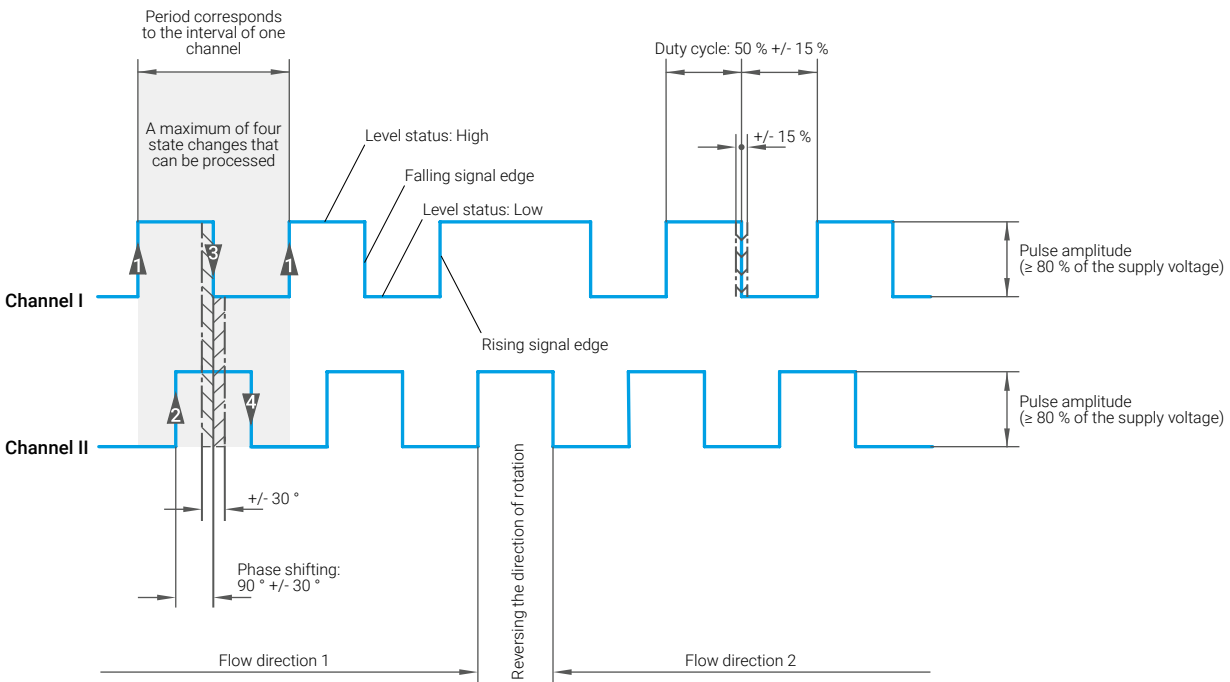

#### Signal behaviour in IO-Link mode



## Electronics

### IO-Link versions

#### Electrical parameters

	IO-Link mode	SIO mode
Number of measuring channels		1 or 2
Supply voltage	24 V	12 ... 24 V
Pulse amplitude		Min <sub>High</sub> ≥ Supply voltage - 2 V Max <sub>Low</sub> ≤ 2 V
Pulse form	–	Square
Duty cycle	–	50 % +/- 15 % (50 % correspond to a 1:1 duty cycle)
Phase shifting (Devices with 2 sensors)	–	90 ° +/- 30 °
Maximum current at the signal output		Push-Pull / 25 mA
Maximum power requirement		2 W
Protection rating		IP 65

#### Notes

With currents of max. 200 mA between the IO-Link device and the IO-Link master, core cross-sections of min. 0.35 mm<sup>2</sup> up to a maximum cable length of 20 m are permissible. The design of the supply line of the IO-Link master from the power supply unit is not affected by this and is the responsibility of the installer/operating company.

#### Technical characteristics

Manufacturer ID	0x0524
Name	VC IO-Link
Vendor ID	0x0524 / 1316
Device ID	0x000001 / 1
Vendor name	Kracht GmbH
IO-Link revision	V1.1
Bit rate	COM3 / 230.4 kbit/s
Minimum cycle time	500µs
SIO mode supported	Yes
Indexed Service Data Unit (ISDU) used	Yes
DS data storage usable	Yes

#### Input process data IO-Link mode

PD input (Process data input): Length 32 bit. Adjustable via variable: Output unit (Index 64)

Name	Description	Data type	Length	Value range	Unit
PDIN_Impulse	When the "Output Unit (64)" is selected, the sensor pulses are output	IntegerT	32 bit	-2.147.483.648 ... 2.147.483.647	–
PDIN_Volume	When the "Output Unit (64)" is selected, the volume is output	Float32T	32 bit	1.175.494.351e-29 ... 3.402.823.466e+38	l (litres)
PDIN_Weight	When the "Output Unit (64)" is selected, the weight is output	Float32T	32 bit	1.175.494.351e-29 ... 3.402.823.466e+38	kg (kilogram)
PDIN_FlowRate	When the "Output Unit (64)" is selected, the flow rate is output	Float32T	32 bit	1.175.494.351e-29 ... 3.402.823.466e+38	l/min (litres per minute)
PDIN_MassFlow	When the "Output Unit (64)" is selected, the mass flow is output	Float32T	32 bit	1.175.494.351e-29 ... 3.402.823.466e+38	kg/min (kilogram per minute)

#### Output process data IO-Link mode

PD output (Process data output): Length 1 bit. Adjustable via variable: Output unit (Index 64)

Name	Description	Data type	Length	Value range	Unit
PDOUT_Impulse	„Reset activated“ sets „PDIN_Impulse“ to value „0“ until „Reset deactivated“ is set	BooleanT	1 bit	true / false	true : Reset activated false : Reset deactivated
PDOUT_Volume	„Reset activated“ sets „PDIN_Volume“ to value „0“ until „Reset deactivated“ is set	BooleanT	1 bit	true / false	true : Reset activated false : Reset deactivated
PDOUT_Weight	„Reset activated“ sets „PDIN_Weight“ to value „0“ until „Reset deactivated“ is set	BooleanT	1 bit	true / false	true : Reset activated false : Reset deactivated
PDOUT_FlowRate	No effect on measurement	BooleanT	1 bit	true / false	–
PDOUT_MassFlow	No effect on measurement	BooleanT	1 bit	true / false	–

## Electronics

### IO-Link versions

#### Variables

Name	Index	Sub-index	Data type	Length	Access-right	Factory setting	Value range	Factor	Unit	Description
<b>Identification menu</b>										
Vendor name	16	0	StringT	11 byte	ro	KRACHT GmbH	-	-	-	-
Vendor text	17	0	StringT	52 byte	ro	Gear Pumps Flow measurement Hydraulics Valves	-	-	-	-
Product name	18	0	StringT	16 byte	ro	Flow meter	-	-	-	-
Product ID	19	0	StringT	2 byte	ro	VC	-	-	-	-
Product text	20	0	StringT	32 byte	ro	VC XXX	-	-	-	-
Serial number	21	0	StringT	10 byte	ro	See type plate	-	-	-	-
Hardware version	22	0	StringT	8 byte	ro	-	-	-	-	-
Firmware version	23	0	StringT	8 byte	ro	Description of the firmware version Firmware versions and changes (Index 23)[>40]	-	-	-	-
Application specifi tag	24	0	StringT	32 byte	rw	***	-	-	-	-
<b>Observation menu</b>										
Pulses	110	0	IntegerT	32 bit	ro	-	-2.147.483.648 ... 2.147.483.647	-	-	Impulses can be queried in each setting of process data
Flow	111	0	Float32T	32 bit	ro	-	1.175.494.351e-29 ... 3.402.823.466e+38	-	l/min	Flow rate can be queried in each setting of process data
<b>Parameter menu</b>										
Output unit	64	0	UIntegerT	8 bit	rw	0	(0) Pulses (15) Litres (52) Kilogram (101) l/min (154) kg/min	-	-	Setting content of process data
V <sub>gz</sub> Factor*	80	0	Float32T	4 byte	rw	1	0.5 ... 1.5	-	-	Factor for adjusting V <sub>gz</sub> , calibration of the tooth volume (Index 80) [>40]
Density	81	0	Float32T	4 byte	rw	1	0.5 ... 15	-	-	Density of medium, calibration of the weight calculation (Index 81) [>80]
<b>Diagnosis menu</b>										
Operating hours	100	0	UIntegerT	2 byte	ro	0	0 ... 65.534	1	-	Operating hours since initial commissioning
Total impulses	101	0	UIntegerT	4 byte	ro	0	0 ... 4.294.967.294	1.000	-	Total impulses since initial commissioning

\* The V<sub>gz</sub> factor is a universal correction factor for impulse volume,  
a term used not only for gear flowmeters but also for screw and turbine flowmeters.

## Electronics

### Encoder versions

#### General

The pre-amplifier generated square-wave signal enables application specific resolutions. Standard resolution means that the electronics will process one pulse from a channel/sensor per periodic time (a rising edge on channel I corresponds to a state change from low to high). The 4-fold evaluation, on the other hand, utilises the maximum number of state changes per period and enables a resolution four times higher than that of the standard evaluation. In this case, all characteristic features of the signal (rising and falling signal edges of both channels/sensors) are utilised during the evaluation.

The duty cycle, the ratio between pulse and periodic time, is theoretically 50 % (1:1 ratio) in an ideal case – but may deviate by +/- 15 % in practice. A tolerance of +/- 30° within the phase shifting of the two measurement channels is possible. Neither of these factors affects the resolution accuracy.

#### Pole assignment – M12x1 circular connector / 4-pole

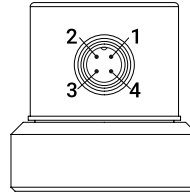

- |   |                |
|---|----------------|
| 1 | Supply voltage |
| 2 | Channel 1      |
| 3 | GND            |
| 4 | Channel 2      |

#### Electrical parameters

Number of measuring channels	2
Supply voltage	11 ... 30 V
Pulse amplitude	Min <sub>High</sub> ≥ Supply voltage - 3 V Max <sub>Low</sub> ≤ 2,5 V
Pulse form	Square
Duty cycle	50 % +/- 15 % (50 % corresponds to a duty factor 1:1)
Signal output	Push-Pull
Phase shifting	90° +/- 30°
Maximum load	+/- 30 mA
Power consumption	Standard 45 mA Maximum 150 mA
Protection rating	IP 65

#### Signal behaviour

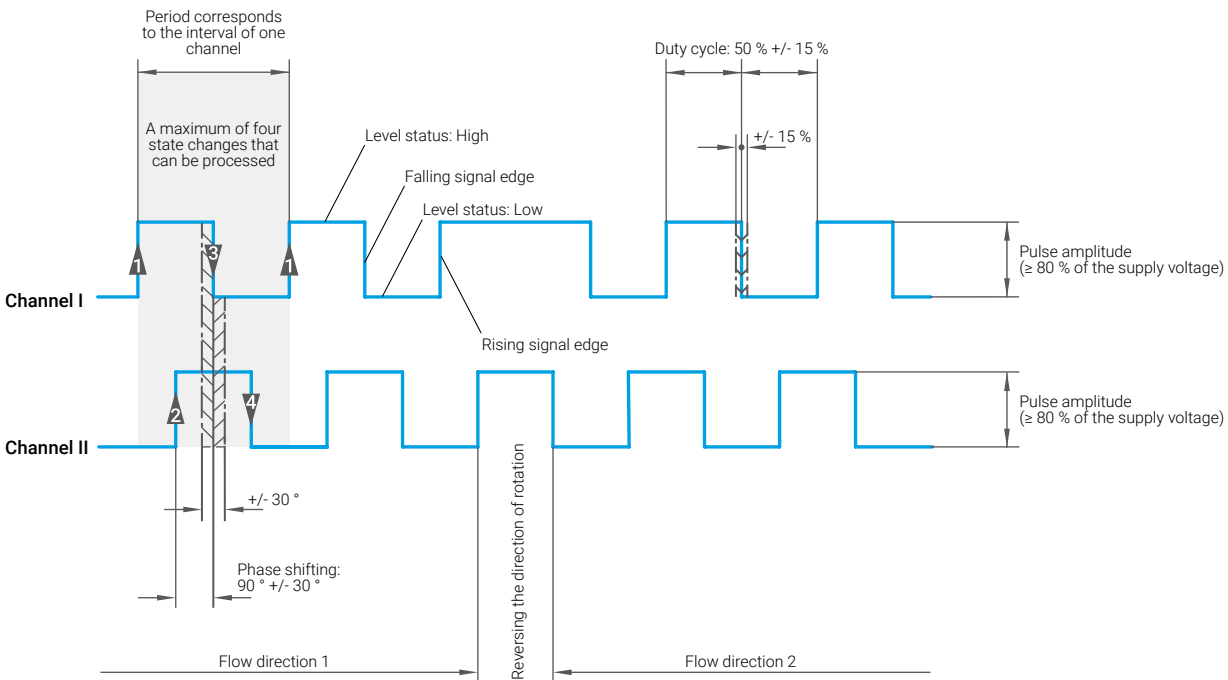

## Electronics

### Explosion-proof versions (ATEX/IECEX)

#### General

- All gear type flow meters are available as explosion-proof versions according to ATEX and IECEx certification.
- The explosion-proof version consists of the gear type flow meter (intrinsically safe electric gear) and the switching amplifier K 130 (accessory electric gear). This layout meets the ignition protection type "intrinsic safety".
- The gear type flow meter is installed in the explosive atmosphere.
- The switching amplifier K 130 is assembled in the safe atmosphere.
- The gear type flow meter is electrically connected with the switching amplifier. The switching amplifier analyses the sensor signals coming from the gear type flow meter and converts them into square-wave signals.
- It is prohibited to deploy the gear type flow meter in explosive atmospheres without switching amplifier.
- The cable between the gear type flow meter and switching amplifier may be up to 400 m long.
- The switching amplifier features LEDs to monitor for line breakage / short circuit, channel switching state, and voltage supply.

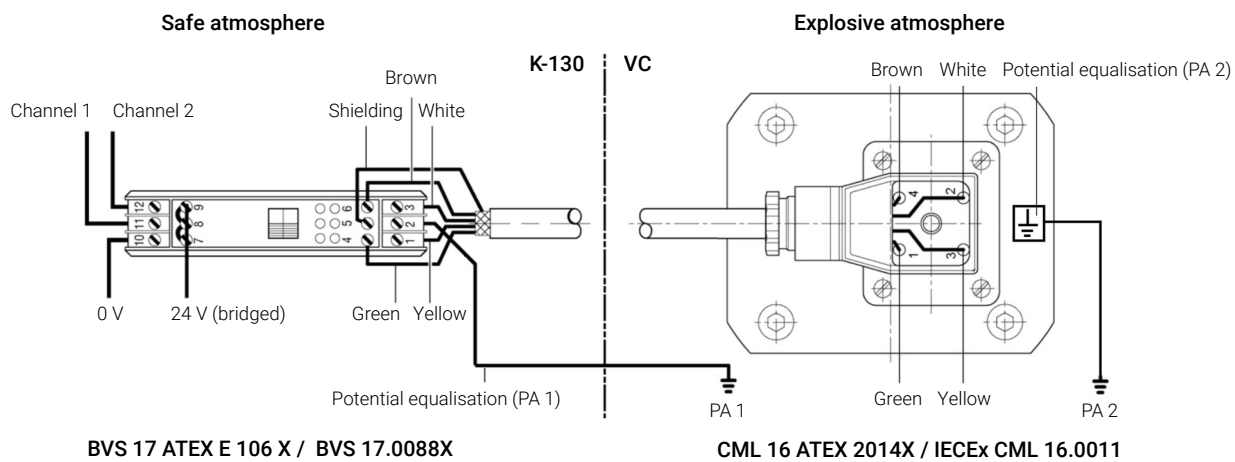

#### Notes

This drawing only serves as an example for the connection of the sensors to the isolating switching amplifier K 130. Observe the applicable standards when assembling a plant in an explosive atmosphere.

Ignition protection marking (device-dependent)

⊕ II 2G Ex ia IIC T4 Gb

⊕ II 2D Ex ia IIIC T135 °C Db

#### Switching amplifier K-130 technical characteristics

<b>Supply</b>	
Supply voltage terminal 7 (L+), terminal 10 (L-)	DC 24 Volt +/- 20 %
<b>Output (not intrinsically safe) / nominal data terminals 9, 12, 8, 11</b>	
Electronic outputs	Electrically isolated via photocoupler
Signal level 1-signal	Output voltage > 15 V
Signal level 0-signal	Output voltage ≤ 5 V
<b>Ambient conditions</b>	
Low threshold temperature	248 K (-25 °C)
High threshold temperature	333 K (+60 °C)
<b>Mechanics</b>	
Dimensions	114.5 x 99 x 22 mm
Mounting	Can be snapped on to 35 mm sectional rail, DIN EN 60715

## Technical drawings

### Spheroidal cast iron versions with integrated electronic – plate mounting

Nominal sizes	Dimensions											Tightening torques in Nm
	A	C	D	F	G*	J	K	L	M	N	P	
VC 0.025	85	10	60	50	101	-	70	40	20	6.7	M6	14
VC 0.04	85	9	60	56	107	-	70	40	20	6.7	M6	14
VC 0.04 / Encoder	85	12	60	48	95	9.65	70	40	20	6.7	M6	14
VC 0.1	85	10	60	55	106	-	70	40	20	9.0	M6	14
VC 0.2	85	13	60	57	108	-	70	40	20	9.0	M6	14
VC 0.2 / Encoder	85	13	60	57	104	10.80	70	40	20	9.0	M6	14
VC 0.4	100	17	90	63	114	-	80	38	34	16.0	M8	35
VC 1	120	13	95	72	123	15.50	84	72	35	16.0	M8	35
VC 1 / Encoder	120	16	95	69	116	18.20	84	72	35	16.0	M8	35
VC 3**	170	18	120	89	140	46.50	46	95	50	25.0	M12	120
VC 5**	170	22	120	105	156	46.50	46	95	50	25.0	M12	120

\* plus 12 mm for high-temperature electronics version  
 plus 6 mm for ATEX/IECEX electronics version

\*\* does not apply to K3 specification (See the section " Spheroidal cast iron versions with integrated electronic – plate mounting – specification K3)

#### Available electronic versions

	Standard	High-temperature	ATEX/IECEX	IO-Link	Encoder	Analogue
VC 0.025 ... 5	•	•	•	•	•	•

#### Versions with Hirschmann connector

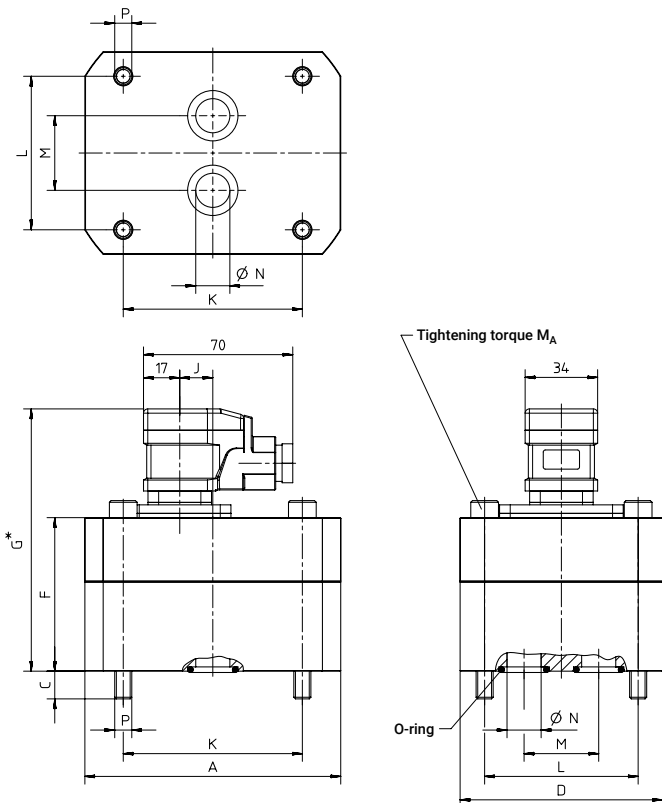

#### Versions with encoder

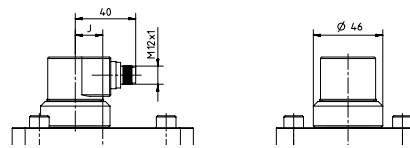

#### Versions with analogue / IO-Link connector

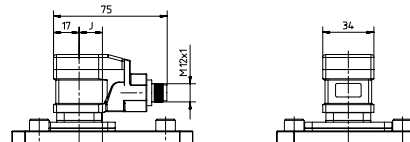

Dimensions in mm

## Technical drawings

### Spheroidal cast iron versions with remote electronic – plate mounting

Nominal sizes	Dimensions											Tightening torques in Nm
	A	C	D	F	G	J	K	L	M	N	P	
VC 0.025	85	10	60	50	87	-	70	40	20	6.7	M6	14
VC 0.04	85	9	60	56	93	-	70	40	20	6.7	M6	14
VC 0.1	85	10	60	55	92	-	70	40	20	9	M6	14
VC 0.2	85	13	60	57	94	-	70	40	20	9	M6	14
VC 0.4	100	17	90	63	100	-	80	38	34	16	M8	35
VC 1	120	13	95	72	109	18.5	84	72	35	16	M8	35
VC 3	170	18	120	89	126	11.0	46	95	50	25	M12	120
VC 5	170	22	120	105	142	11.0	46	95	50	25	M12	120

### Available electronic versions

	High-temperature PLUS	High-temperature PLUS ATEX/IECEX	Low-temperature
VC 0.025 ... 5	•	•	-

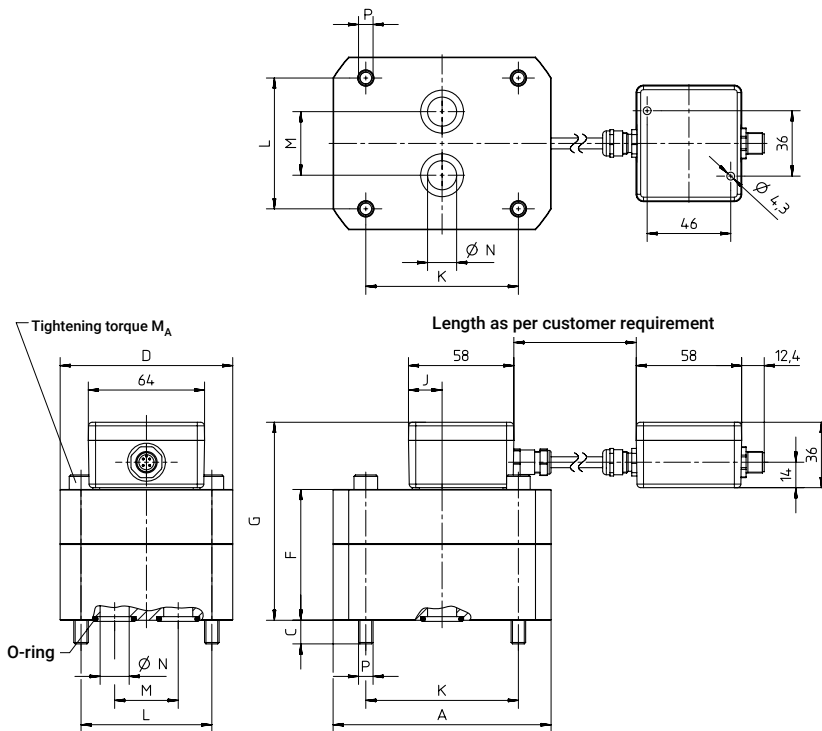

## Technical drawings

### Spheroidal cast iron versions with integrated electronic – plate mounting – specification K3

Nominal sizes	Dimensions										Tightening torques in Nm
	C	D	F	G*	J	K	L	M	N	P	
VC 3	23	179	99	150	46.5	46	95	50	25	M12	145
VC 5	22	179	115	166	46.5	46	95	50	25	M12	145
VC 12	44	249	168	219	78.0	120	140	70	38	M20	400
VC 16	38	249	184	235	78.0	120	140	70	38	M20	400

\* plus 12 mm for high-temperature electronic version  
plus 6 mm for ATEX/IECEx electronics version

#### Available electronic versions

	Standard	High-temperature	ATEX/IECEx	IO-Link	Encoder	Analogue
VC 3 ... 16	•	•	•	•	-	•

#### Versions with Hirschmann connector

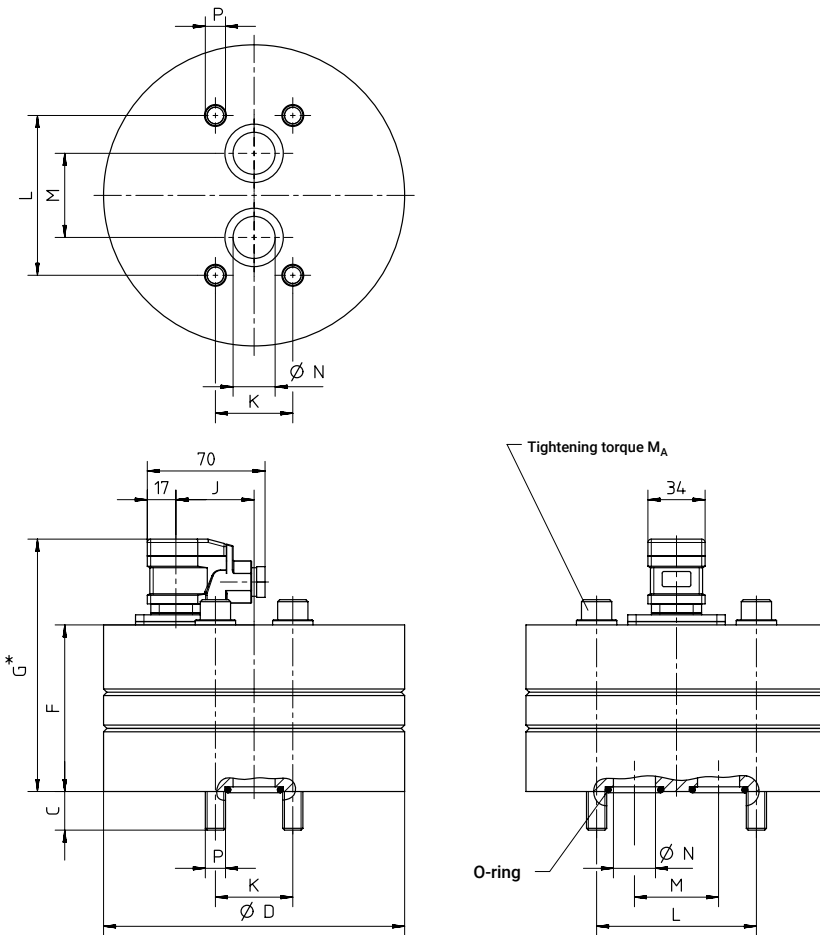

#### Versions with analogue / IO-Link connector

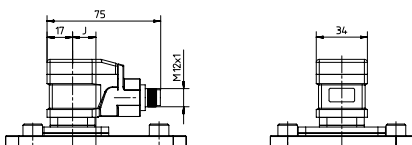

Dimensions in mm

Technical drawings

Spheroidal cast iron versions with remote electronic – plate mounting – specification K3

Nominal sizes	Dimensions										Tightening torques in Nm
	C	D	F	G	J	K	L	M	N	P	
VC 3	23	179	99	136	-	46	95	50	25	M12	120
VC 5	22	179	115	152	11	46	95	50	25	M12	120
VC 12	44	249	168	205	48	120	140	70	38	M20	400
VC 16	38	249	184	221	48	120	140	70	38	M20	400

Available electronic versions

	High-temperature PLUS	High-temperature PLUS ATEX/IECEX	Low-temperature
VC 3 ... 16	•	•	-

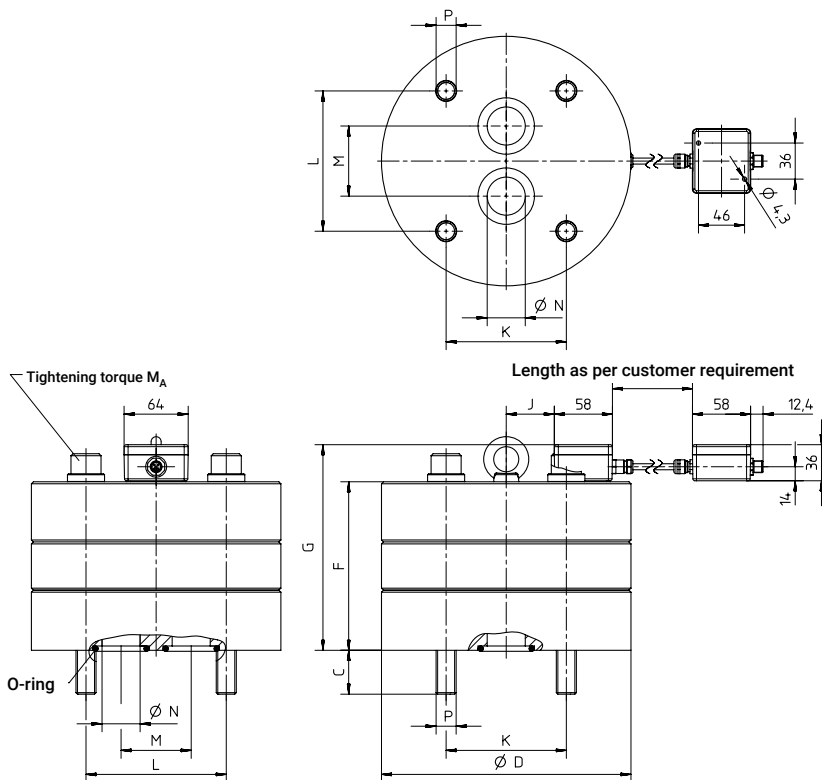

## Technical drawings

### Stainless steel versions with integrated electronic – plate mounting

Nominal sizes	Dimensions										Tightening torques in Nm
	C	D	F	G*	J	K	L	M	N	P	
VC 0.025	10	94	55	106	-	70	40	20	6.7	M6	14
VC 0.04	9	94	56	107	-	70	40	20	6.7	M6	14
VC 0.1	10	94	55	106	-	70	40	20	9.0	M6	14
VC 0.2	13	94	57	108	-	70	40	20	9.0	M6	14
VC 0.4	17	118	63	114	-	80	38	34	16.0	M8	35
VC 1	13	124	72	123	15.5	84	72	35	16.0	M8	35
VC 3	18	170	89	140	46.5	46	95	50	25.0	M12	120
VC 5	22	170	105	156	46.5	46	95	50	25.0	M12	120

\* plus 12 mm for high-temperature electronic version  
plus 6 mm for ATEX/IECEX electronics version

### Available electronic versions

	Standard	High-temperature	ATEX/IECEX	IO-Link	Encoder	Analogue
VC 0.025 ... 5	•	•	•	•	-	•

### Versions with Hirschmann connector

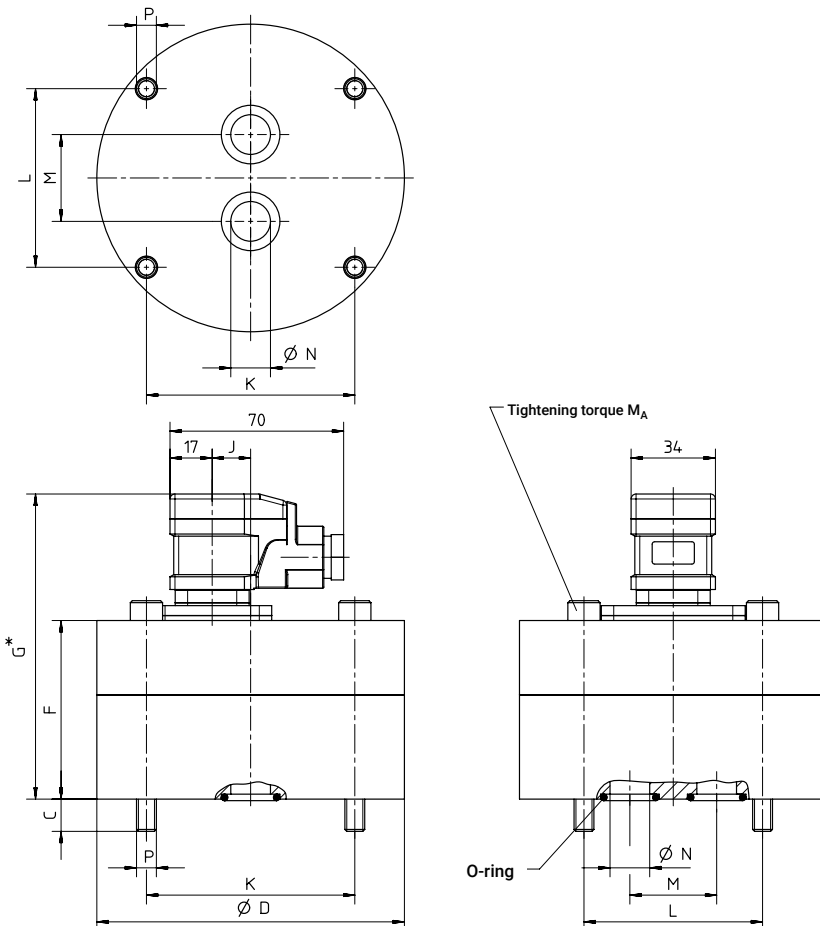

### Versions with analogue / IO-Link connector

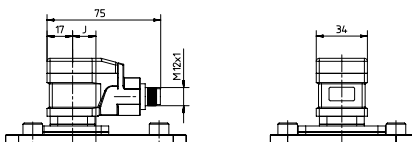

Dimensions in mm

## Technical drawings

### Stainless steel versions with remote electronic – plate mounting

Nominal sizes	Dimensions										Tightening torques in Nm
	C	D	F	G	J	K	L	M	N	P	
VC 0.025	10	94	55	92	-	70	40	20	6.7	M6	14
VC 0.04	9	94	56	93	-	70	40	20	6.7	M6	14
VC 0.1	10	94	55	92	-	70	40	20	9.0	M6	14
VC 0.2	13	94	57	94	-	70	40	20	9.0	M6	14
VC 0.4	17	118	63	100	-	80	38	34	16.0	M8	35
VC 1	13	124	72	109	18.5	84	72	35	16.0	M8	35
VC 3	18	170	89	126	11.0	46	95	50	25.0	M12	120
VC 5	22	170	105	142	11.0	46	95	50	25.0	M12	120

### Available electronic versions

	High-temperature PLUS	High-temperature PLUS ATEX/IECEX	Low-temperature
VC 0.025 ... 5	•	•	•

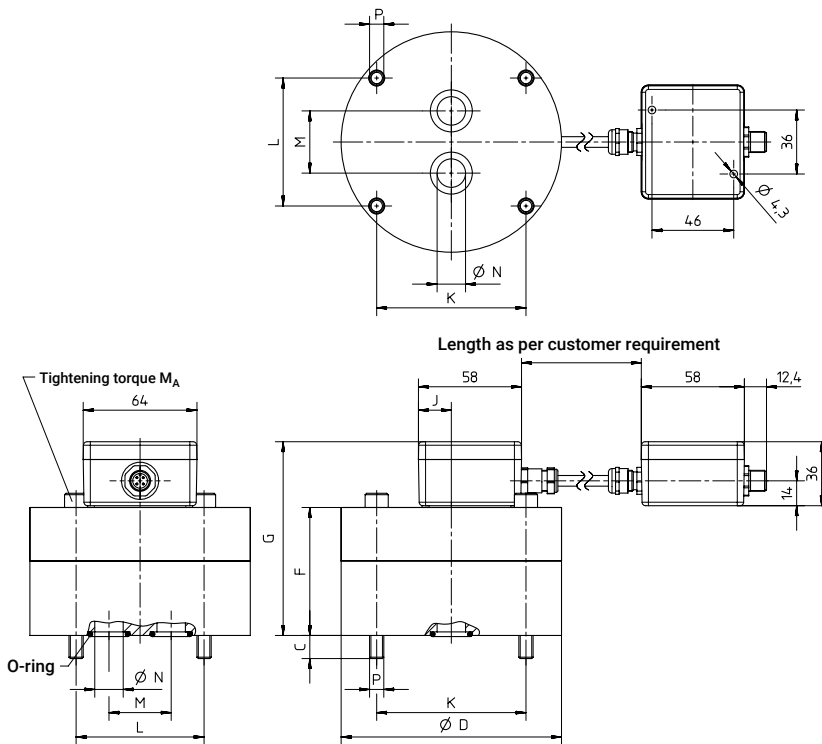

**Technical drawings**

**Stainless steel versions with integrated electronic – pipe connection**

Nominal sizes	Dimensions											
	A	B	C	D	E	F	G*	H	J	K	L	R
VC 0.025	G <sup>1/8</sup>	9	17.0	94	90	55	106	15.0	-	70	40	6.7
VC 0.04	G <sup>1/4</sup>	13	21.0	94	90	56	107	15.0	-	70	40	6.7
VC 0.1	G <sup>3/8</sup>	13	25.0	94	90	55	106	15.0	-	70	40	6.6
VC 0.2	G <sup>3/8</sup>	13	25.0	94	90	57	108	16.0	-	70	40	6.5
VC 0.4	G <sup>1/2</sup>	15	29.0	118	114	63	114	17.5	-	80	38	9.0
VC 1	G <sup>1/2</sup>	15	29.0	124	120	72	123	22.0	15.5	84	72	9.0
VC 3	G1	19	51.5	170	162	89	140	30.0	46.5	46	95	13.0
VC 5	G1	19	42.0	170	162	105	156	30.0	46.5	46	95	13.0

\* plus 12 mm for high-temperature electronic version  
 plus 6 mm for ATEX/IECEX electronics version

**Available electronic versions**

	Standard	High-temperature	ATEX/IECEX	IO-Link	Encoder	Analogue
VC 0.025 ... 5	•	•	•	•	-	•

**Versions with Hirschmann connector**

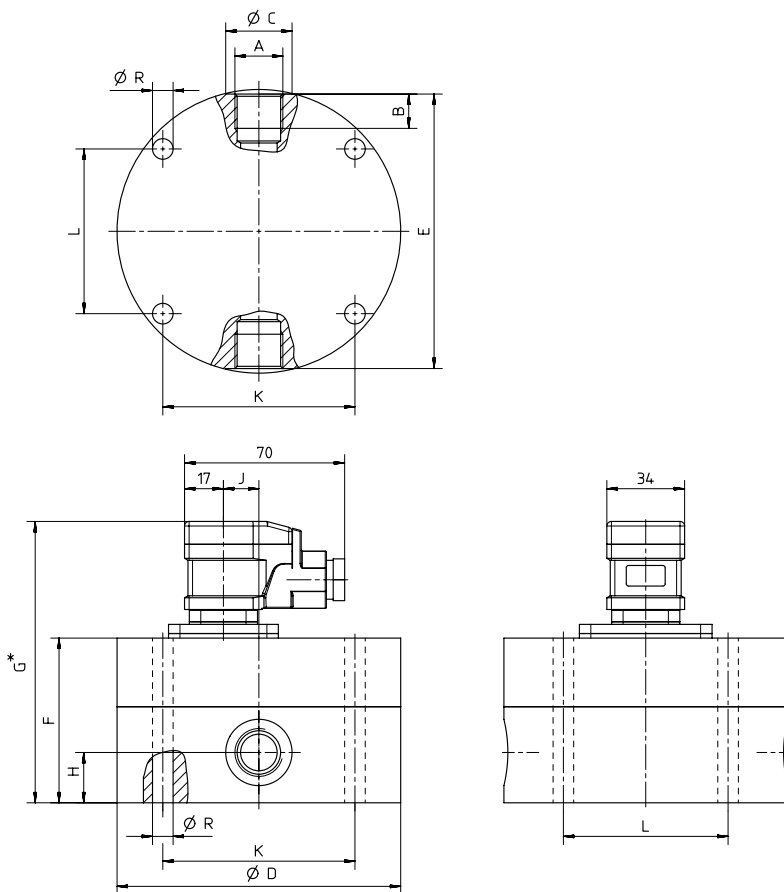

**Versions with analogue / IO-Link connector**

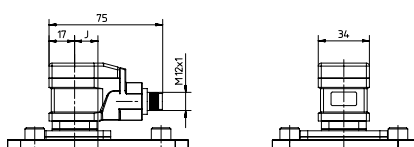

Dimensions in mm

## Technical drawings

### Connection plates (cast iron) with lateral threaded connection

Ordering codes	Dimensions																		Weights
	e	A	B	C	E	F	G	H	J	K	L	M	N	P	R	c	d	f	
<b>MVC 0.2 R3 B05*</b>	G <sup>3</sup> / <sub>8</sub>	85	90	35	65	76	7	11	7	70	40	20	6.5	M6 - 14 deep	17.0	0.7	25	13	1.8
<b>MVC 0.2 R3 C05*</b>	G <sup>1</sup> / <sub>2</sub>	85	90	35	65	76	7	11	7	70	40	20	6.5	M6 - 14 deep	17.5	0.7	29	15	1.7
<b>MVC 0.4 R1 C09</b>	G <sup>1</sup> / <sub>2</sub>	100	110	37	86	96	7	11	7	80	38	34	16	M8 - 18 deep	18.5	0.7	29	15	2.7
<b>MVC 0.4 R1 D09</b>	G <sup>3</sup> / <sub>4</sub>	100	110	42	86	96	7	11	7	80	38	34	16	M8 - 18 deep	21.0	1.0	36	17	2.9
<b>MVC 1 R2 C09</b>	G <sup>1</sup> / <sub>2</sub>	100	120	37	80	106	7	11	7	84	72	35	12	M8 - 18 deep	17.5	0.7	29	15	2.9
<b>MVC 1 R3 D05</b>	G <sup>3</sup> / <sub>4</sub>	120	120	42	80	106	7	11	7	84	72	35	13	M8 - 18 deep	21.0	1.0	36	17	4.0
<b>MVC 1 R2 E05</b>	G1	100	120	65	80	106	7	11	8	84	72	35	13	M8 - 18 deep	32.5	1.0	42	19	4.9
<b>MVC 5 R2 E05**</b>	G1	160	165	80	140	145	9	15	9	46	95	50	25	M12 - 24 deep	28.0	1.0	42	19	14.0
<b>MVC 5 R2 G09**</b>	G1 <sup>1</sup> / <sub>2</sub>	170	165	100	140	145	9	15	9	46	95	50	25	M12 - 24 deep	42.0	1.0	58	23	17.8

\* Suitable for VC 0.025, VC 0.04, VC 0.1 and VC 0.2 as well as VC 0.2 with encoder

\*\* Suitable for VC 3 and VC 5

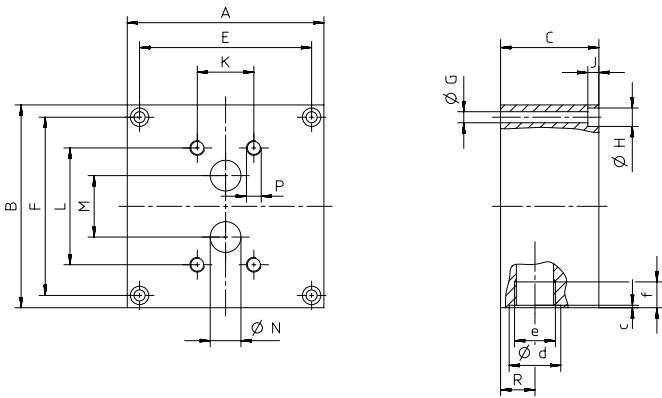

### Connection plates (cast iron) with rear threaded connection

Ordering codes	Dimensions																		Weights
	e	A	B	C	E	F	G	H	J	K	L	M	N	P	R	c	d	f	
<b>MVC 0.2 R3 B04*</b>	G <sup>3</sup> / <sub>8</sub>	85	90	35	65	76	7	11	7	70	40	20	6.5	M6 - 14 deep	28	0.7	25	13	1.6
<b>MVC 0.4 R1 C08</b>	G <sup>1</sup> / <sub>2</sub>	100	110	37	86	96	7	11	7	80	38	34	16	M8 - 18 deep	46	0.7	29	15	2.5
<b>MVC 0.4 R1 D08</b>	G <sup>3</sup> / <sub>4</sub>	100	110	42	86	96	7	11	7	80	38	34	16	M8 - 18 deep	52	1.0	36	17	2.9
<b>MVC 1 R2 C04</b>	G <sup>1</sup> / <sub>2</sub>	100	120	37	80	106	7	11	7	84	72	35	12	M8 - 18 deep	50	0.7	29	15	2.7
<b>MVC 5 R2 E04**</b>	G1	160	165	55	140	145	9	15	9	46	95	50	25	M12 - 24 deep	55	1.0	42	19	9.6

\* Suitable for VC 0.025, VC 0.04, VC 0.1 and VC 0.2 as well as VC 0.2 with encoder

\*\* Suitable for VC 3 and VC 5

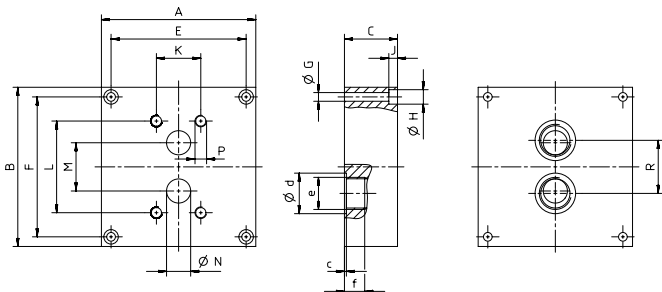

## Technical drawings

### Connection plates (stainless steel) with lateral threaded connection

Ordering codes	Dimensions															Weights
	e	B	C	D	E	G	H	J	K	L	M	N	P	R	f	
<b>MVC 0.2 R4 B11*</b>	G <sup>3</sup> / <sub>8</sub>	85	35	94	75	7	11	7	70	40	20	6.5	M6 - 14 deep	18.0	13	1.7
<b>MVC 1 R3 C11</b>	G <sup>1</sup> / <sub>2</sub>	116	37	124	100	9	15	9	84	72	35	12.0	M8 - 18 deep	19.5	15	3.2
<b>MVC 1 R2 D11</b>	G <sup>3</sup> / <sub>4</sub>	116	42	124	100	9	15	9	84	72	35	12.0	M8 - 18 deep	21.0	17	3.5
<b>MVC 5 R2 E11**</b>	G1	158	80	170	140	9	15	9	46	95	50	25.0	M12 - 24 deep	52.0	19	13.9
<b>MVC 5 R2 G11**</b>	G <sup>1</sup> / <sub>2</sub>	158	105	170	140	9	15	9	46	95	50	25.0	M12 - 24 deep	63.0	23	17.9

\* Suitable for VC 0.025, VC 0.04, VC 0.1 and VC 0.2 as well as VC 0.2 with encoder

\*\* Suitable for VC 3 and VC 5

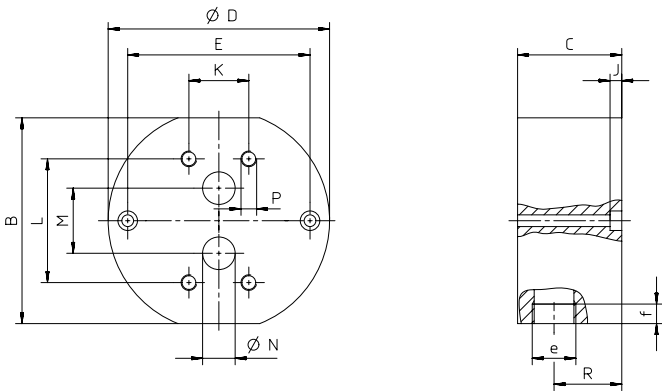

### Connection plates (spheroidal cast iron) with lateral SAE flange connection for VC 3, 5, 12 and 16 in K3 specification

Ordering codes	Dimensions															Weights	
	B	C	D	E	F	G	K	L	M	N	P	R	a	b	e		f
<b>MVC 5 V1 E09</b>	150	90	180	110	110	M8 - 24 deep	46	95	50	25	M12 - 24 deep	50	57.2	27.8	25	M12 - 24 deep	14.20
<b>MVC 12 V1 G09</b>	200	140	249	120	140	M10 - 20 deep	120	140	70	38	M20 - 45 deep	70	79.38	36.5	38	M16 - 25 deep	41.18

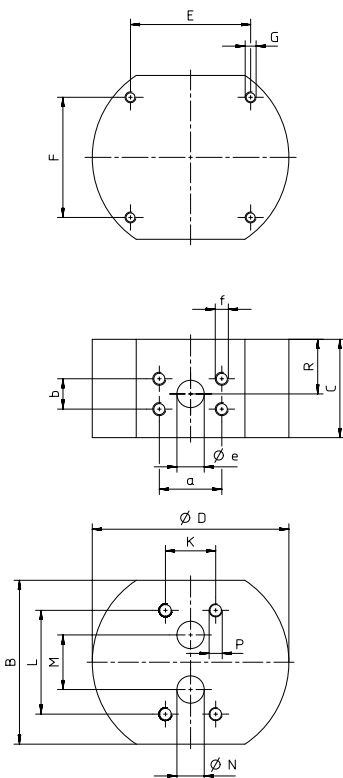

Dimensions in mm / Weights in kg







**KRACHT CORP.**

6552 Weatherfield Court  
Maumee, OH 43537

**Phone:** +1 419 874 1000

**E-Mail:** [sales@krachtcorp.com](mailto:sales@krachtcorp.com)

**[krachtcorp.com](http://krachtcorp.com)**

Errors and technical changes reserved  
VC/US/06.2026

■ **Part of Atlas Copco Group**

**KRACHT**<sup>®</sup>  
FLUID TECHNOLOGY AND SYSTEMS