

SPV

PRESSURE RELIEF VALVES



KRACHT®
FLUID TECHNOLOGY AND SYSTEMS

Content

General	4
Construction / Description / Function	
Technical data	5
General characteristics / Hydraulic characteristics / Materials / Temperatures / Weights	
Δp -Q characteristic curves	6 - 7
Type key	8
Explosion protection version (Atex)	9
Technical drawings	
Valves	10 - 11
Technical drawings / Technical specifications	
Accessories – Weld-on flanges	12

General

Construction

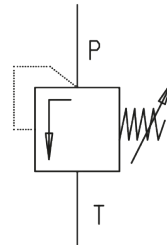
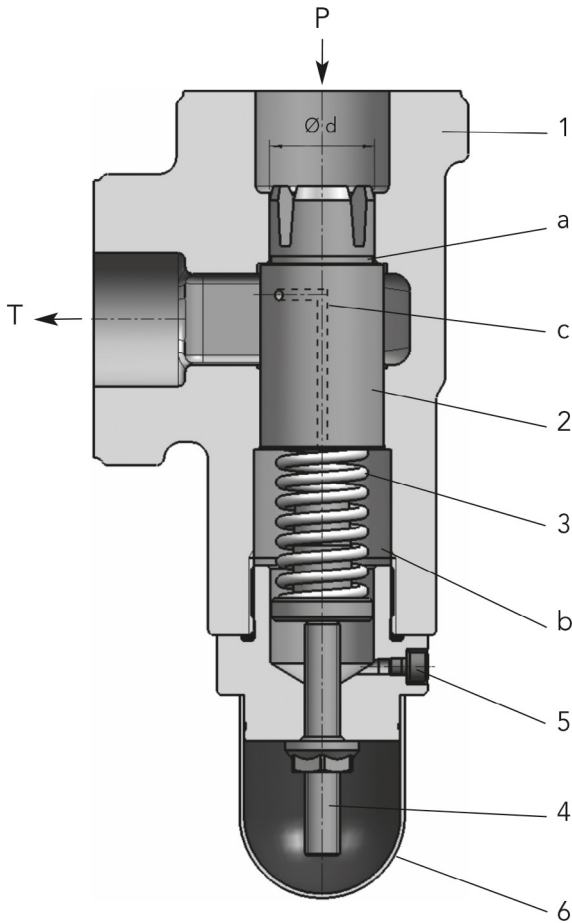

- 1 Housing
- 2 Sliding piston
- 3 Compression spring
- 4 Set screw
- 5 Bleeding screw
- 6 Protective cap
- a Ring surface
- b Spring chamber
- c Bore hole
- d Diameter
- P Pressure connection
- T Tank connection

Description

The pressure relief valve SPV is a direct spring sliding piston valve. It is intended for mounting in pipelines and is suitable to safeguard low pressure hydraulic circuits.

The pipe connection is to be effected either by SAE mounting surfaces or by Whitworth pipe threads.

Notes

When using strongly aerated media, the valve should preferably be mounted vertical with the set screw facing down.

The tank connection T of the valve must not be exposed to underpressure when subject to flow, as in this case the valve cannot be ventilated, possibly resulting in unwanted vibrations and noise. If this cannot be avoided, version 3 „vibration-damped, with damping nozzle“ should be selected under item 10 in the type code.

Function

The sliding piston 2 is pressed against the annular surface a by the compression spring 3 and thus blocks the pressure connection P from the tank connection T via the diameter d. When the opening pressure, set by the adjusting screw 4, is reached, the sliding piston 2 releases the fluid flow to the tank connection. The spring chamber b is relieved through the hole c. When commissioning the valve, the spring chamber b must be vented using the bleeding screw 5. In order to achieve an optimum characteristic curve, the valves are available in several pressure stages for the respective pressure setting ranges.

Technical data

General characteristics

Nominal sizes	10 · 20 · 25 · 32 · 40 · 50 · 80
Types of construction	Slide valve – directly operated Seat valve Ball valve
Mounting types	Pipe installation Flange Panel installation
Hydraulic connections	Flange connection SAE (ISO 6162-1 / SAE J518) Pipe thread (ISO 228-1)
Mounting positions	Any, pressure adjustment screw at the bottom preferred
Pressure adjustment types	Mechanical, adjusting screw Mechanical, rotary handle
Pressure fluids	Hydraulic oils acc. to DIN 51 524/25 (other fluids on request)

Hydraulic characteristics

Nominal sizes	10	20	25	32	40	50	80
Maximum flow rates	40 l/min	90 l/min	90 l/min	450 l/min	450 l/min	550 l/min	800 l/min
Nominal pressures	120 bar	120 bar	120 bar	120 bar	120 bar	100 bar	80 bar
Viscosities	1.2 ... 1000 mm ² /s (higher viscosities on request)						
Δp-Q characteristic curves	See the section „Technical data – Δp-Q characteristic curves“						
	Setting ranges / Set pressures						
Pressure stage 002	-	0.5 ... 2.5	0.5 ... 2.5	0.5 ... 2.5	0.5 ... 2.5	0.5 ... 2.5	0.5 ... 2.5
Pressure stage 005	-	2.0 ... 5.0	2.0 ... 5.0	2.0 ... 5.0	2.0 ... 5.0	2.0 ... 5.0	2.0 ... 5.0
Pressure stage 007	0.5 ... 7.0	2.0 ... 7.0	2.0 ... 7.0	2.0 ... 7.0	2.0 ... 7.0	-	-
Pressure stage 012	4.0 ... 12.0	4.0 ... 12.0	4.0 ... 12.0	4.0 ... 12.0	4.0 ... 12.0	4.0 ... 12.0	4.0 ... 12.0
Pressure stage 020	-	10.0 ... 20.0	10.0 ... 20.0	10.0 ... 20.0	10.0 ... 20.0	10.0 ... 20.0	10.0 ... 20.0
Pressure stage 025	-	19.0 ... 25.0	19.0 ... 25.0	19.0 ... 25.0	19.0 ... 25.0	19.0 ... 25.0	-
Pressure stage 030	10.0 ... 30.0	-	-	10.0 ... 30.0	10.0 ... 30.0	-	-
Pressure stage 040	-	20.0 ... 40.0	20.0 ... 40.0	-	-	-	-

Materials

Housings	Grey cast iron Spheroidal graphite cast iron	EN-GJL-300 EN-GJS-400-15
Sealings	FKM, NBR, Copper, Soft iron	
Compression springs	Spring steel	
Cap nuts	Polypropylene	
Other parts	Steel	

Note:

Metal protective cap (cap nut) for Atex version

Temperatures

Media temperatures	FKM	-15 ... 150 °C
	NBR	-20 ... 90 °C
	Copper	-20 ... 220 °C
	Soft iron	-40 ... 220 °C
Ambient temperatures	FKM	-15 ... 60 °C
	NBR	-20 ... 60 °C
	Copper	-20 ... 60 °C
	Soft iron	-40 ... 60 °C

Weights

Nominal sizes						
10	20	25	32	40	50	80
0.9 kg	3.0 kg	3.0 kg	5.5 kg	6.0 kg	8.2 kg	18.5 kg

Technical data

Δp -Q characteristic curves

Possible setting ranges of the pressure stages, viscosity = 34 mm²/s

SPV 10

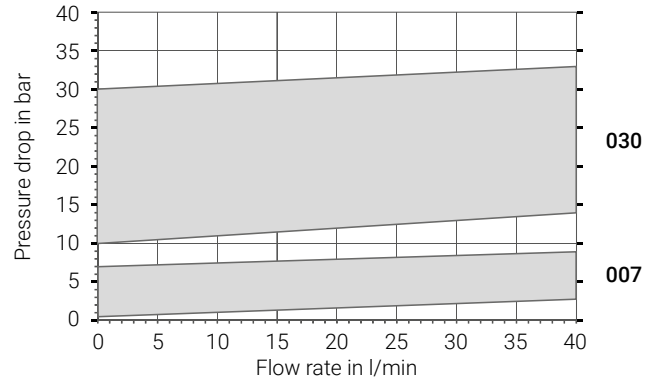
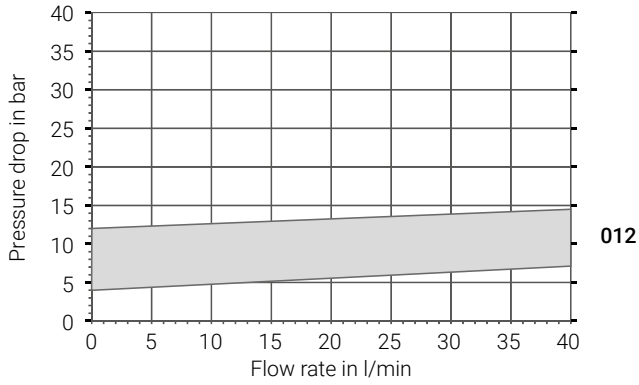

SPV 20/25

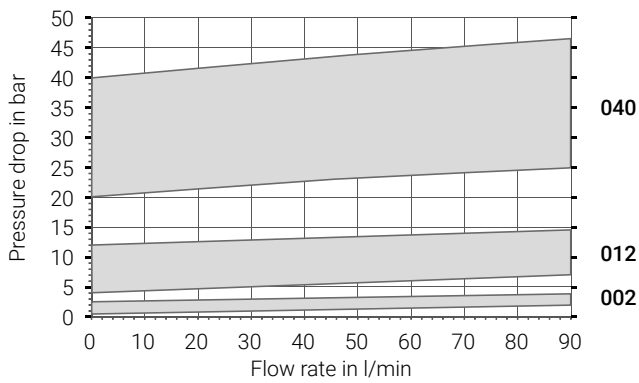
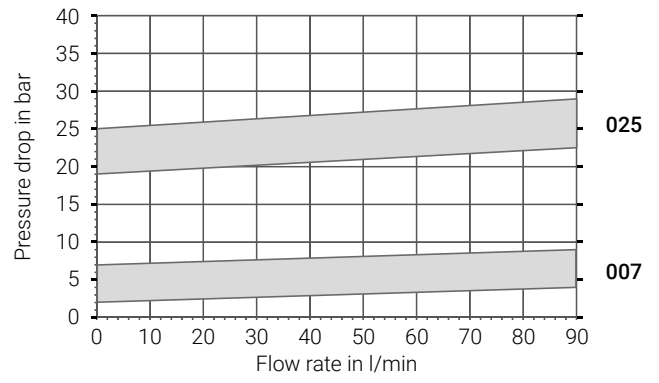
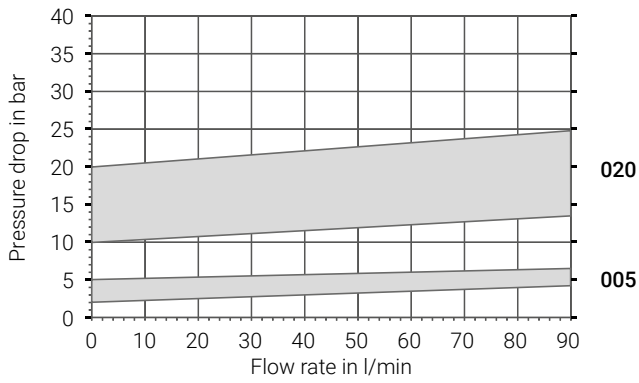

Technical data

Δp -Q characteristic curves

Possible setting ranges of the pressure stages, viscosity = 34 mm²/s

SPV 32/40

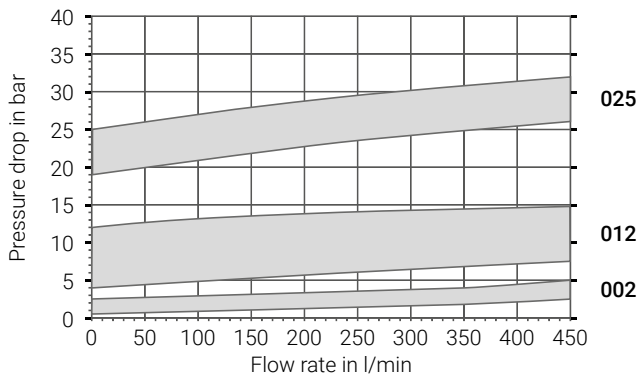
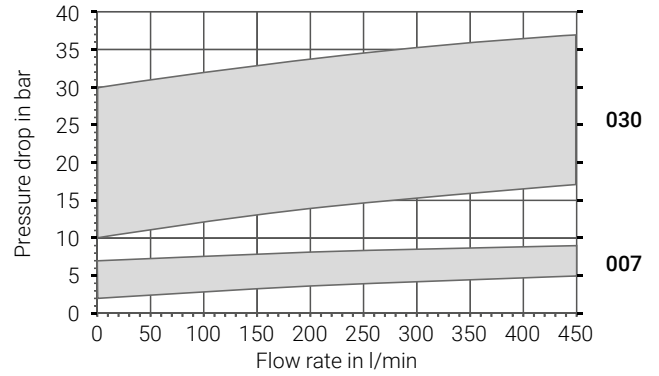
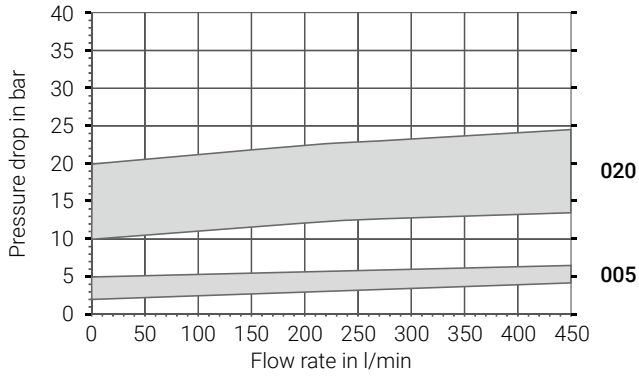

SPV 50

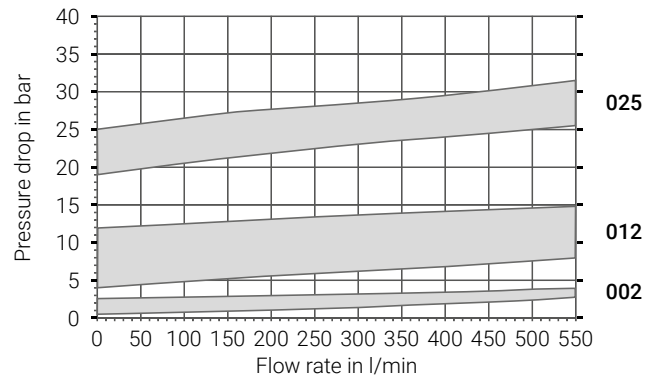
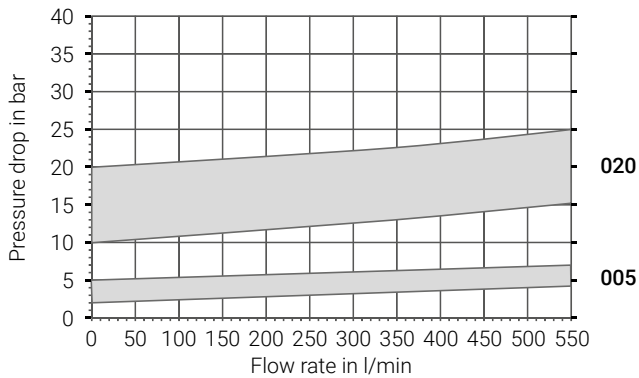

SPV 80

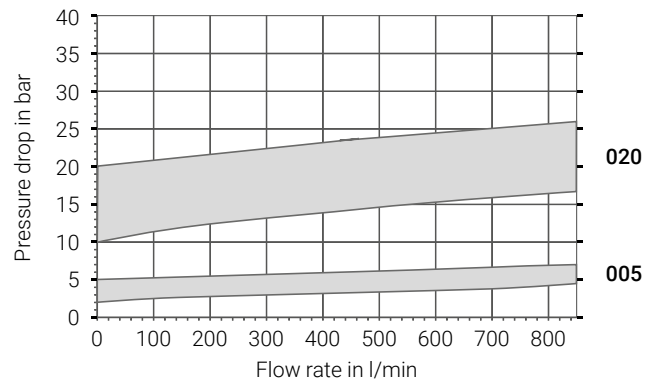
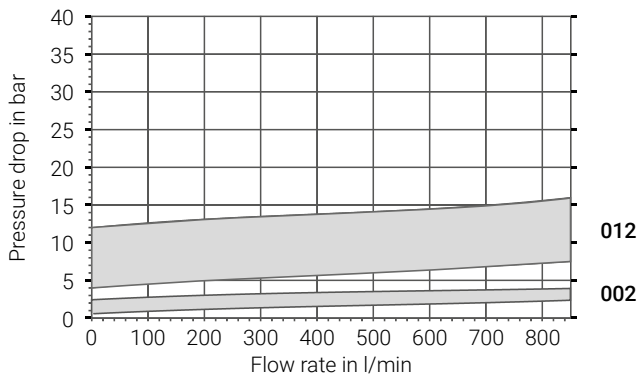

Type key

SPV	20	V	1	F	1	S	007	S	1	A	/	00.
1	2	3	4	5	6	7	8	9	10	11		12

1 Product	
SPV	Pressure relief valve

2 Nominal sizes	
10 · 20 · 25 · 32 · 40 · 50 · 80	

3 Types of construction		Nominal sizes
V	Slide valve	10 ... 80
S	Seat valve	20 ... 40
L	Ball valve	10

4 Housing materials		
1	Grey cast iron	EN-GJL-300
2	Spheroidal graphite cast iron	EN-GJS-400-15

5 Sealing materials	
F	FKM
N	NBR
K	Copper
W	Soft iron

6 Pressure adjustment types		Nominal sizes
1	Adjusting screw, manual	10 ... 80
2	Manual rotary handle	10 ... 40
3	Adjusting screw, manual, panel installation	10 ... 25
4	Rotary handle, manual, panel installation	10 ... 25
5	Adjusting screw, sealed	10 ... 80

7 Hydraulic connections		Nominal sizes
S	Flange connection SAE (ISO 6162-1)	20 ... 80
R	Pipe thread (ISO 228-1)	10 ... 80

8 Pressure stages (Pressure setting ranges)		Nominal sizes
002	0.5 ... 2.5 bar	20 ... 80
005	2 ... 5 bar	20 ... 80
007	0.5 ... 7 bar	10
	2 ... 7 bar	20 ... 40
012	4 ... 12 bar	10 ... 80
020	10 ... 20 bar	20 ... 80
025	19 ... 25 bar	20 ... 50
030	10 ... 30 bar	10 · 32 ... 40
040	20 ... 40 bar	20 ... 25
000	Special pressure level	On request

9 Media temperatures		
S	Standard	... 150 °C
H	High temperature	... 220 °C
X	Atex	... 80 °C

10 Viscosities / damping		
1	Standard	... 1000 mm ² /s
2	High viscosity	on request
3	Vibration-damped, damping nozzle	

11 Hydraulic controls	
A	Without hydraulic control
E	External spring space relief

12 Special numbers	
00.	On request

Explosion protection version (Atex)

Explosion protection – field of application for the pressure relief valves

The valve is used to secure low pressure hydraulic circuits with various flammable and non-flammable fluids.

They can be used:

1. In zone 2 (Gas-Ex, Category 3G)
in the explosion groups IIA, IIB and IIC
2. In zone 22 (Dust-Ex, Category 3D)
in the explosion groups IIIA and IIIB
3. In zone 1 (Gas-Ex, Category 2G)
in explosion groups IIA, IIB and IIC
4. In zone 21 (Dust-Ex, Category 2D)
in the explosion groups IIIA and IIIB

The qualification for the surface temperature is T4; for all gases, vapours, mists with an ignition temperature >135 °C, the operating materials are not an ignition source.

In the Dust-Ex area, 135 °C is the reference temperature for further considerations regarding the safety margin to the glow temperature, etc. (can only be decided by the operating company).

The permissible ambient temperature ranges from
-20 ... +60 °C (NBR, Copper, Soft iron)
-15 ... +60 °C (FKM)

Flashpoint, minimum ignition temperature and mediaspecific attributes must be complied with by the operating organisation.

Not allow any explosive mixture to be present inside the unit.

The permissible media temperature ranges from
-20 ... +80 °C (NBR, Copper, Soft iron)
-15 ... +80 °C (FKM)

Technical drawings

Nominal size 10

Media temperatures	Standard	High temperature	Atex
Pressure adjustment types	Adjusting screw	Adjusting screw	Adjusting screw
Hydraulic connections	Pipe thread	Pipe thread	Pipe thread

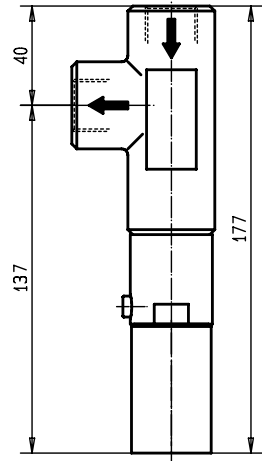
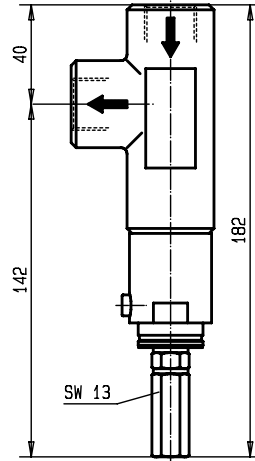
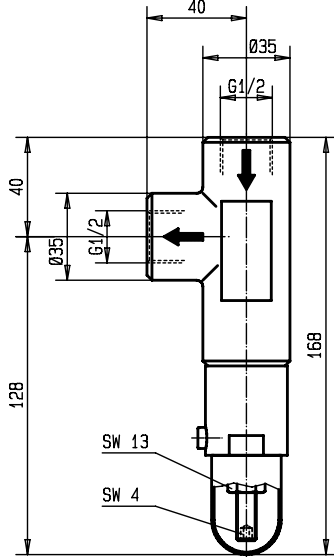

Media temperatures	Standard	Standard	Standard
Pressure adjustment types	Rotary handle	Rotary handle, panel installation	Adjusting screw, panel installation
Hydraulic connections	Pipe thread	Pipe thread	Pipe thread

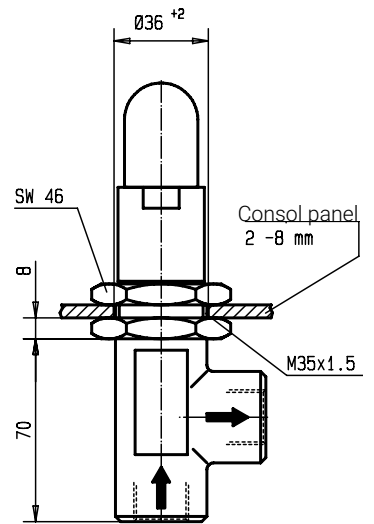
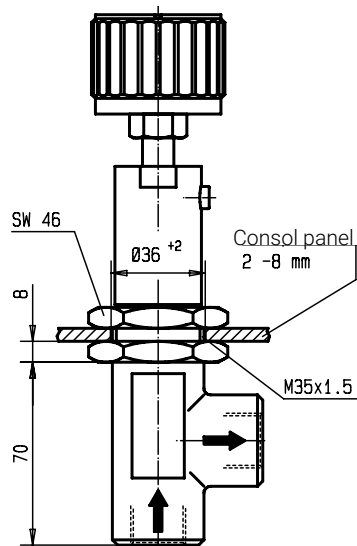
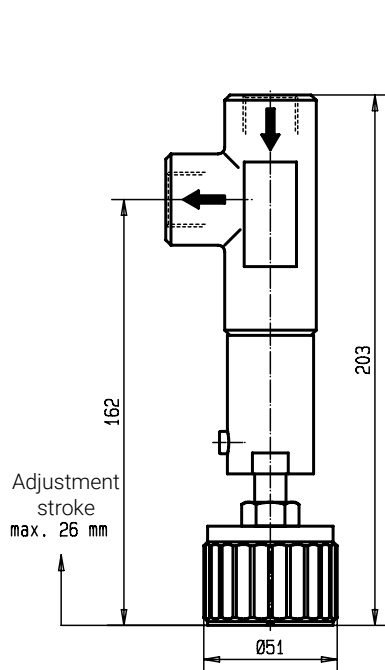

Technical drawings

Nominal sizes 20 ... 80

Media temperatures	Standard	High temperature
Pressure adjustment types	Adjusting screw	Adjusting screw
Hydraulic connections	Flange connection SAE	Flange connection SAE

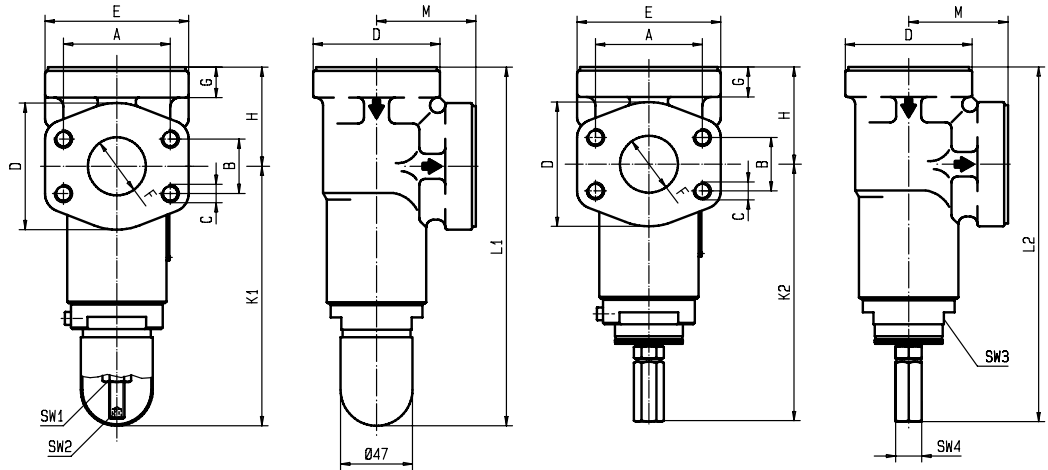

Media temperatures	Atex
Pressure adjustment types	Adjusting screw
Hydraulic connections	Flange connection SAE

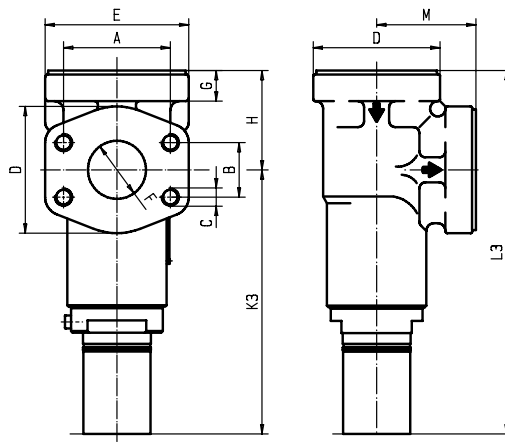

Nominal sizes	SAE flanges	Thread R	A	B	C	D	E	F	G	H	K1	K2	K3	L1	L2	L3	M	Spanner sizes			
																		SW1	SW2	SW3	SW4
20	3/4"	G3/4	47.6	22.2	M10	59	70	24	20	50	160	167	169	210	217	227	50	17	5	46	17
25	1"	G1	52.4	26.2	M10	59	70	24	20	50	160	167	169	210	217	227	55	17	5	46	17
32	1 1/4"	G1 1/4	58.7	30.2	M10	72	79	32	20	65	165	172	174	230	237	247	65	17	5	46	17
40	1 1/2"	G1 1/2	69.9	35.7	M12	83	94	38	20	65	165	172	174	230	237	247	65	17	5	46	17
50	2"	G2	77.8	42.9	M12	97	102	50.5	20	75	192	209	212	267	284	284	75	19	6	46	19
80	3"	G3	106.4	61.9	M16	131	135	79	25	110	190	207	208	300	317	315	110	19	6	-	19

Technical drawings / Technical specifications

Accessories – Weld-on flanges SAE (ISO 6162-1)

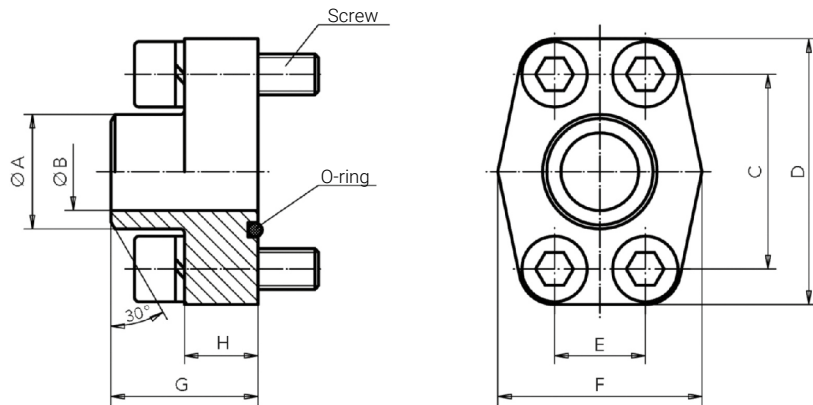

SAE flanges	A	B	C	D	E	F	G	H	Screws 10.9	O-rings	Maximum pressures in bar	Weights
3/4"	28.0	19.0	47.63	65	22.23	50	36	18	M10x35	24.99 x 3.53	350	0.46
1"	34.0	25.0	52.37	70	26.19	55	38	18	M10x35	32.92 x 3.53	315	0.54
1 1/4"	42.8	32.0	58.72	79	30.18	68	41	21	M10x40	37.69 x 3.53	250	0.78
1 1/2"	48.6	38.0	69.85	93	35.71	78	44	25	M12x45	47.22 x 3.53	200	1.24
2"	61.0	51.0	77.77	102	42.88	90	45	25	M12x45	56.74 x 3.53	200	1.40
3"	92.0	73.0	106.38	134	61.93	124	50	27	M16x50	85.32 x 3.53	138	2.54

KRACHT GmbH

Gewerbestrasse 20
58791 Werdohl, Germany
Phone: +49 2392 935 0
E-Mail: info@kracht.eu

kracht.eu

Errors and technical changes reserved
SPV/EN/06.2026

■ **Part of Atlas Copco Group**

KRACHT[®]
FLUID TECHNOLOGY AND SYSTEMS