

KRACHT[®]

- | Gear Pumps
- | Flow Measurement
- | Hydraulics
- | Valves

Gear Pumps

KF-F 2.5 ... 630

for fuels



Description

I Construction

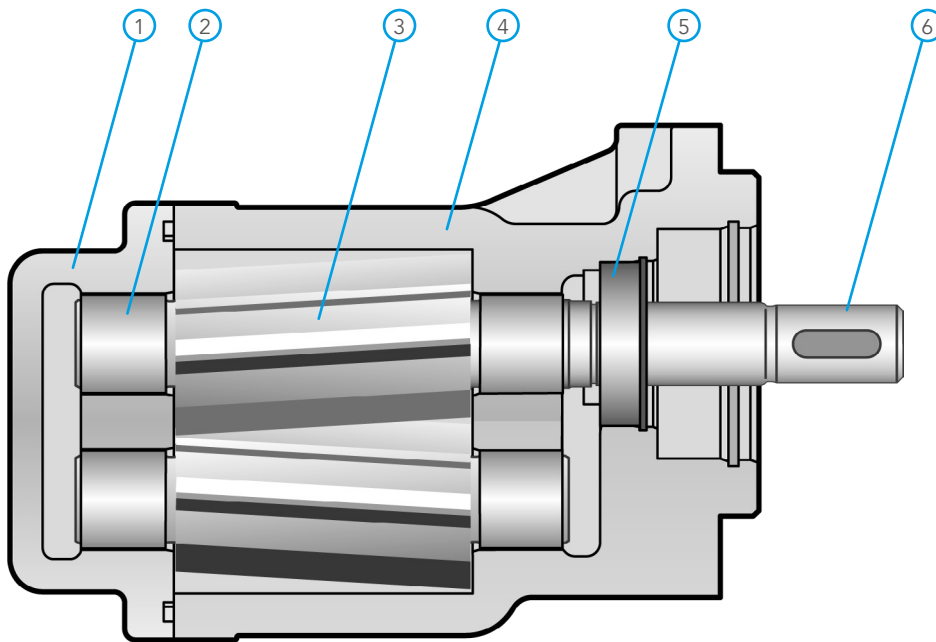

- 1 End cover
- 2 Plain bearing bushes
- 3 Gear unit
- 4 Housing
- 5 Shaft seal
- 6 Drive shaft end

I Description

The Type KF-F transfer pumps were developed specifically for use with fuels, especially for marine fuels. These need to be critically considered, especially regarding the lubricity. And above all, those with low sulphur. Diesel fuels (MGO/DMA) exhibit low lubricity, which cannot be determined through the viscosity. Special methods are available for determining the tribological properties.

The HFRR test acc ISO 12156 is a recognised method for measuring the lubricity of diesel fuels. The characteristic value determined using this method is referred to as Wear Scar Diameter (WSD) and increases with decreasing lubricity. This characteristic value is stated by the fuel manufacturers and can be included when assessing the stability of components.

The KF-F fuel pumps are durable up to a WSD value of 520 µm, which is the minimum lubricity of MGO and DMA according to ISO 8217.

Furthermore, the pumps exhibit extremely good efficiency, especially at high speeds.

The KF-F pumps can be used without restrictions for pumping fuels with low sulphur content, MGO/DMA (gas oil) acc ISO 8217 (see working characteristics).

Direction of Rotation

The following should be note for direction of rotation:

- when looking at the pump shaft end, the direction of pumping is from left to right if the shaft rotates clockwise.
- when looking at the pump shaft end, the direction of pumping is from right to left if the shaft rotates counterclockwise.

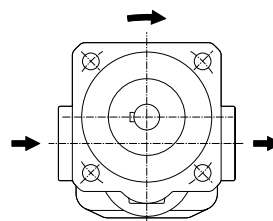

suction side pressure side
pump running cw

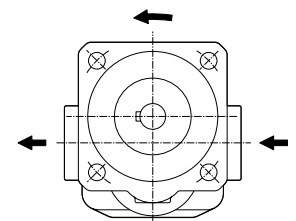

pressure side suction side
pump running ccw

Technical data

I Materials

Housing and cover	EN-GJS-400-15 (GGG 40)
Gear	Steel 1.7139
Bearing	Multi-layer friction type bearing
Shaft end seals	Rotary shaft lip-type seal FKM Mechanical seal FKM Magnetic coupling
O-rings	FKM

I Properties of fuels

Viscosity	$v_{\min} = 1,2 \text{ mm}^2/\text{s}$ $v_{\max} = 20\,000 \text{ mm}^2/\text{s}$ (dependent on pressure, speed and lubricity)
Lubricity HFRR-test (according to ISO 12156)	WSD $\leq 520 \mu\text{m}$ (meet the requirements of ISO 8217 for marine fuels)

I Characteristics

Nominal sizes	2,5 ... 630
Direction of rotation	right or left
Fixing type	flange (DIN ISO 3019)
Pipe connection	KF-F 2,5 ... 25 Whitworth-pipe thread, SAE flange KF-F 32 ... 630 SAE flange
Drive shaft end	ISO R 775 short-cylindrical
Fuel temperature	-10 ... 150 °C
Ambient temperature	-20 ... 60 °C
Working pressure inlet port	see chart page 5
Working pressure outlet port	$p_{\max} = 12 \text{ bar}$ at $v = 1,2 \text{ mm}^2/\text{s}$ für 2,5 ... 630 cm^3 $p_{\max} = 25 \text{ bar}$ at $v \geq 12 \text{ mm}^2/\text{s}$ (dependent on viscosity)
Driving Speed	2,5 ... 63 cm^3 $n = 200 \dots 3600 \text{ rpm}$ 80 ... 180 cm^3 $n = 200 \dots 3000 \text{ rpm}$ 200 cm^3 $n = 200 \dots 2500 \text{ rpm}$ 250 ... 630 cm^3 $n = 200 \dots 2000 \text{ rpm}$ (observe the restricted drive speed for higher viscosities)
Volumetric efficiency	strongly dependent to drive speed, viscosity and pressure Example: 6 bar, 2 mm^2/s , 1450 rpm: $\eta > 70\%$ 6 bar, 2 mm^2/s , 3600 rpm: $\eta > 90\%$

Technical data

I Operating parameters

Nominal size	geom. displacement	Working pressure* at $v \geq 12\text{mm}^2/\text{s}$	Maximum pressure	Speed range		Sound level		
	cm ³ /rev			bar	bar	n_{\min} at rpm	n_{\max} at rpm	p = 5 bar
2,5	2,55	25	40	200	3600	≤65	≤66	≤67
4	4,03	25	40	200	3600	≤65	≤66	≤67
5	5,05	25	40	200	3600	≤65	≤66	≤67
6	6,38	25	40	200	3600	≤65	≤66	≤67
8	8,05	25	40	200	3600	≤65	≤66	≤67
10	10,11	25	40	200	3600	≤65	≤66	≤67
12	12,58	25	40	200	3600	≤65	≤66	≤67
16	16,09	25	40	200	3600	≤65	≤66	≤67
20	20,10	25	40	200	3600	≤65	≤66	≤67
25	25,10	25	40	200	3600	≤65	≤66	≤67
32	32,12	25	40	200	3600	≤67	≤68	≤68
40	40,21	25	40	200	3600	≤67	≤68	≤68
50	50,20	25	40	200	3600	≤67	≤68	≤68
63	63,18	25	40	200	3600	≤67	≤68	≤68
80	80,50	25	40	200	3000	≤67	≤68	≤69
100	101,50	25	40	200	3000	≤67	≤68	≤69
112	113,50	25	40	200	3000	≤67	≤68	≤69
125	129,40	25	40	200	3000	≤70	≤70	≤70
150	155,60	25	40	200	3000	≤70	≤70	≤70
180	186,60	25	40	200	3000	≤70	≤70	≤70
200	206,20	25	40	200	3000	≤70	≤70	≤70
250	245,10	25	40	200	3000	≤75	≤75	≤75
315	312,90	25	40	200	3000	≤75	≤75	≤75
400	399,50	25	40	200	3000	≤77	≤77	≤77
500	496,50	25	40	200	3000	≤77	≤77	≤77
630	622,50	25	40	200	2500	≤80	≤80	≤80

Remark:

* Working pressure p_b = perm. sustained pressure
 For certain working conditions, the minimum or maximum characteristics should not be used.
 For example, the max. working pressure is not permissible in combination with low speed and low viscosity.

In such limit ranges, please consult us.

Sound level: measured in dB(A) at 1 m distance /
 with drive motor

Installation site: Works hall, quiet sound level = 40 dB(A),
 Pump assembly on rigid fastening angle,
 Suction and pressure conduits:
 Hose Measured with transmission oil,
 Oil viscosity $v = 34\text{ mm}^2/\text{s}$

Technical data

I Shaft End Seals

	Speed	Pressure inlet port						Fuel temperature
		bar						°C
		KF-F 2,5 ... 63	KF-F 80	KF-F 100 ... 180	KF-F 200	KF-F 250 ... 315	KF-F 400 ... 630	
Pump with rotary shaft lip-type seal and double rotary shaft lip-type seal	max. 750 rpm	-0,4 ... 6,0	-0,4 ... 6,0	-0,4 ... 6,0	-0,4 ... 6,0	-0,4 ... 5,5	-0,4 ... 5,0	-20 ... 150
	max. 1000 rpm	-0,4 ... 5,0	-0,4 ... 5,0	-0,4 ... 5,0	-0,4 ... 5,0	-0,4 ... 4,5	-0,4 ... 4,0	-20 ... 150
	max. 1500 rpm	-0,4 ... 4,0	-0,4 ... 4,0	-0,4 ... 3,5	-0,4 ... 3,5	-0,4 ... 3,0	-0,4 ... 2,5	-20 ... 150
	max. 2000 rpm	-0,4 ... 3,0	-0,4 ... 3,0	-0,4 ... 2,5	-0,4 ... 2,5	-0,4 ... 2,0	-0,4 ... 1,5	-20 ... 150
	max. 2500 rpm	-0,4 ... 2,5	-0,4 ... 2,5	-0,4 ... 2,0	-0,4 ... 2,0	–	–	-20 ... 150
	max. 3000 rpm	-0,4 ... 2,0	-0,4 ... 2,0	-0,4 ... 1,5	–	–	–	-20 ... 150
	max. 3600 rpm	-0,4 ... 1,5	–	–	–	–	–	-20 ... 150
Pump with mechanical seal		-0,4 ... 10,0						-20 ... 150
Pump with magnetic coupling		see page 9						-20 ... 150

I Variants

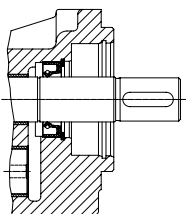

Pump with
rotary shaft lip-type seal
Type of seal 2

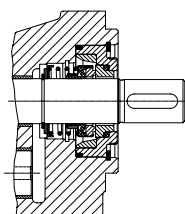

Pump with mechanical seal
Type of seal 5

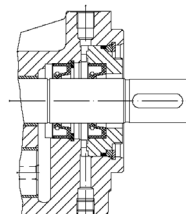

Pump with
double rotary shaft lip-type seal
Type of seal 7

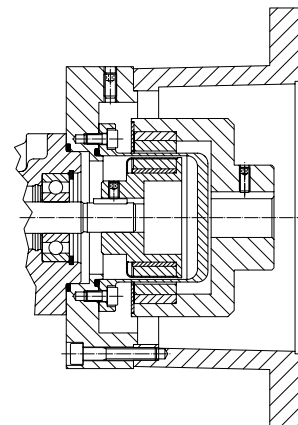

Pump with magnetic coupling

Type key

Example

KF-F	40	R	F	2	-	/...	-	D 15	GJS
1	2	3	4	5		6		7	8

1 Product	
2 Nominal size	
2,5 ... 630	
3 Direction of rotation	
B	right and left (Delivery direction changes)
L	left
R	right
4 Mounting	
F	DIN flange without outboard bearing
G	DIN flange with outboard bearing
W	Angle foot without outboard bearing (KFF 2,5 ... 200)
X	Angle foot with outboard bearing (KFF 2,5 ... 200)
5 Sealing	
2	Rotary shaft lip-type seal FKM
5	Mechanical seal with FKM secondary seals
7	Double rotary shaft lip-type seal FKM
40	Gleitringsdichtung mit FKM-Nebendichtungen
6 Special No.	
158	KF-F 2,5 ... 12 SAE 3/4"-connection
158	KF-F 16 ... 25 SAE 1"-connection
232	KF-F 50 ... 80 SAE 2"-connection
232	KF-F 100/125 SAE 2 1/2"-connection
232	KF-F 125/150 SAE 3"-connection
232	KF-F 180/200 SAE 3 1/2"-connection
7 Pressure valve	
D15	adjustable from 0 ... 15 bar
D25	adjustable from 15 ... 25 bar
8 Housing and cover material	
GJS	EN-GJS-400 (GGG 40)

Notes

I Gear Pumps

Low and high-pressure gear pumps for lubricating oil, hydraulic, process and test bench applications, fuel and metering systems.



I Flow Measurement

Gear, turbine and screw type flow meters and electronics for volume and flow, metering and consumption in the chemical industry, hydraulic, process and test bench technology.



I Hydraulics

Single and multistage high-pressure gear pumps, gear motors and valves for construction machinery, municipal vehicles, agricultural vehicles, special vehicles and truck bodies.



I Valves

Cetop valves for all requirements stationary and mobile applications. Pressure, switching and stop valves with pipe connection for high flow rates. Special valves.



KRACHT®

KRACHT GmbH · Gewerbestraße 20 · 58791 Werdohl, Germany
 Phone +49 2392.935 0 · Fax +49 2392.935 209
 E-Mail info@kracht.eu · Web www.kracht.eu