

Gear pumps
KF 1 coated

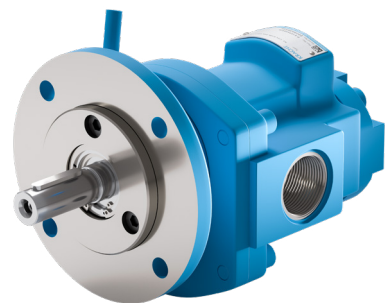

KRACHT®
FLUID TECHNOLOGY AND SYSTEMS

Description Construction	4
Characteristics Working Characteristics Materials	5
Physical characteristics Technical data (discharge flow / drive power)	6
Dimensions and weights	7
Type key	8
Calculation of input power	9
Characteristic curves	10 - 11

General

I Description

The central element in numerous technical processes is the metering of liquids. PU components, plasticisers, resins, adhesives, lacquers and paints are just a few of the important liquids with a broad application spectrum.

The accuracy, uniformity and reproducibility with which these liquids can be processed is also decisive for the quality of the final product.

Ideal for these applications is the KRACHT gear pump KF 1 coated. The KF 1 coated are external gear pumps with a discharge volume of 4 ... 24 cm³/rev.

I Construction

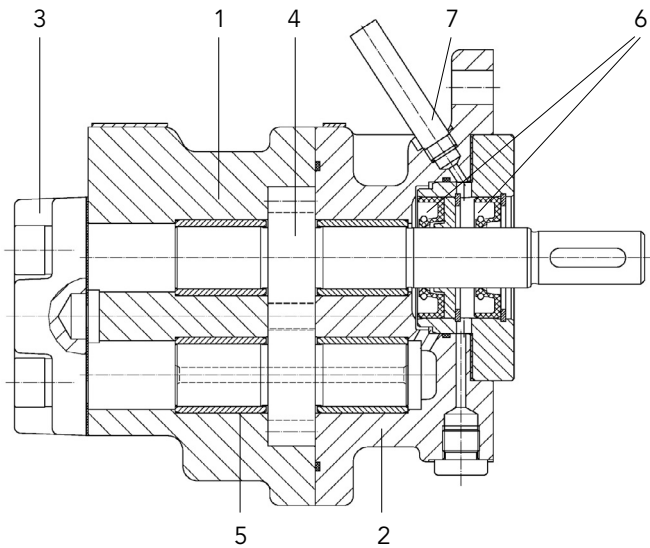

- 1 Housing
- 2 Flange cover
- 3 End cover
- 4 Gear
- 5 Plain bearing bush
- 6 Shaft end sealing
- 7 Port for liquid sealing

All gear parts and bearing bushes are protected against wear and corrosion by means of a special coating, so that also filled media up to a certain particle size and hardness of the fillers can be pumped.

Guide values in this respect are a maximum particle size of 30 µm and a Mohs hardness of 6.

The double rotary shaft seals enable operation with sealing liquid (quench) to prevent hardening or crystallising of the pumped medium.

On request the KF 1 coated can be supplied with a magnetic drive.

Technical data

I Characteristics

Mounting	Flange type
Pipe connection	Threaded ports
Direction of rotation	cw or ccw
Fitting position	Optional
Weight	See page 7

I Working characteristics

Nominal size in cm ³ /rev	4 · 8 · 11 · 16 · 20 · 24
Working pressure	
Inlet port	min max
Outlet port	max
Speed	200 ... 2 000 1/min (depends of viscosity)
Viscosity	12 ... 15 000 mm ² /s (higher viscosities on request)
Media temperature	-10 ... 150 °C for FKM-rotary shaft sealing / 200 °C for PTFE-rotary shaft sealing
Ambient temperature	-20 ... 60 °C

I Materials

Housing	EN-GJL-250
Gear	Steel 1.7139 nickel plated (with SiC inlets)
Bearing bushes	Steel ETG 100 nickel plated (with SiC inlets)
Seals	FKM, PTFE

Technical data

I Physical characteristics

Nominal size	Geometrical displacement	Working pressure	Max. pressure	Permitted forces (n = 1450 1/min)		Moment of inertia (without coupling) x 10 ⁻⁴
				Radial	Axial	
	in cm ³ /rev	in bar	in bar	in N	in N	in kg x m ²
4	4.6	50	60	500	100	0.20
8	8.3					0.35
11	11.3					0.45
16	16.6					0.65
20	20.5					0.75
24	24.8		0.87			
			50			

Kinematic viscosity in mm ² /s	<	300	400	500	1 000	2 000	3 000	6 000	10 000	20 000	30 000
Maximum speed in 1/min	≥	1 500	1 250	1 000	750	600	500	400	300	200	100

I Discharge flow and required drive power for speed n = 1450 1/min

Pressure in bar													Nominal size	Pressure in bar												
2	6	10	14	18	20	22	25	30	35	40	45	50		2	6	10	14	18	20	22	25	30	35	40	45	50
6.6	6.4	6.2	6.0	5.8	5.7	5.6	5.5	5.3	5.0	4.8	4.5	4.3	4	0.10	0.16	0.21	0.26	0.31	0.33	0.36	0.40	0.47	0.53	0.60	0.66	0.73
12.0	11.7	11.4	11.1	10.8	10.7	10.5	10.3	9.9	9.6	9.2	8.8	8.5	8	0.20	0.28	0.36	0.45	0.54	0.58	0.62	0.69	0.80	0.90	1.00	1.10	1.20
16.1	15.9	15.6	15.2	14.8	14.6	14.4	14.2	13.8	13.4	13.0	12.6	12.1	11	0.22	0.33	0.38	0.55	0.65	0.71	0.77	0.85	0.99	1.12	1.26	1.40	1.53
23.8	23.4	23.0	22.7	22.3	22.1	21.9	21.6	21.1	20.6	20.2	19.7	19.2	16	0.25	0.40	0.55	0.70	0.85	0.93	1.00	1.12	1.31	1.50	1.69	1.88	2.07
29.4	29.0	28.6	28.2	27.8	27.6	27.4	27.1	26.2	26.1	25.6	25.1	24.6	20	0.27	0.37	0.65	0.85	1.05	1.15	1.25	1.40	1.65	1.90	2.10	2.40	2.60
35.6	35.2	34.8	34.4	34.0	33.8	33.6	33.3	32.8	32.3	31.8	31.3	30.8	24	0.29	0.54	0.78	1.03	1.30	1.40	1.50	1.70	2.00	2.30	2.60	2.90	3.20
Discharge flow in l/min														Required drive power in kW												

The ratings refer to mineral oil with a viscosity of 34 mm²/s.
 The dispersion of the discharge flow as specified in the table may be -5 ...+2.5 %.
 At viscosities of < 30 mm²/s: Reduction of discharge flow.
 The drive motor output must be selected 20 % higher than the data as specified in the table.
 For viscosity of > 100 mm²/s, the power input must be increased.

Technical data

I Dimensions and weights

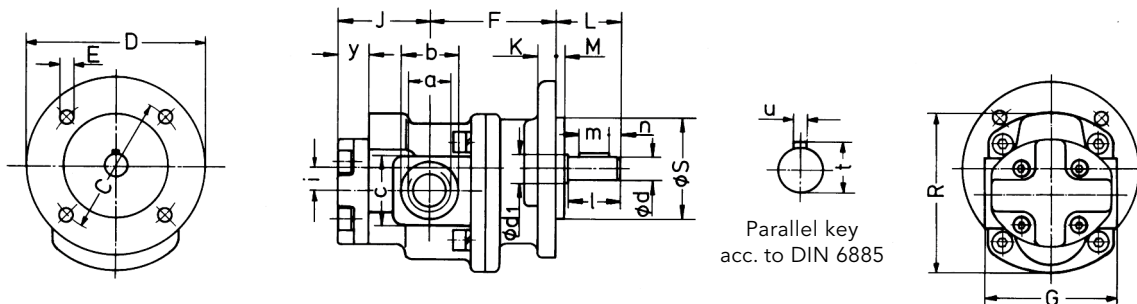

Nominal size	Inlet and outlet ports Pipe thread																Shaft end					Weight ca.		
	a	b	c	C	D	E	F	G	J	K	L	M	R	S _{h6}	i	y	d ₁	d _{K6}	l	m	n	t	u	kg
4	G½ - 16 deep	29	40	90	110	9	64	85	38	11	40	5	100	65	15.5	20	16	14	30	20	5	16	5	3.00
8	G¾ - 17 deep	36					70		57															3.70
11	G¾ - 17 deep	36					70		57															3.75
16	G¾ - 17 deep	36					70		57															3.80
20	G¾ - 17 deep	36					80		57															4.10
24	G¾ - 17 deep	36					80		57															4.20

I Dimensions and weights with pressure relief valve

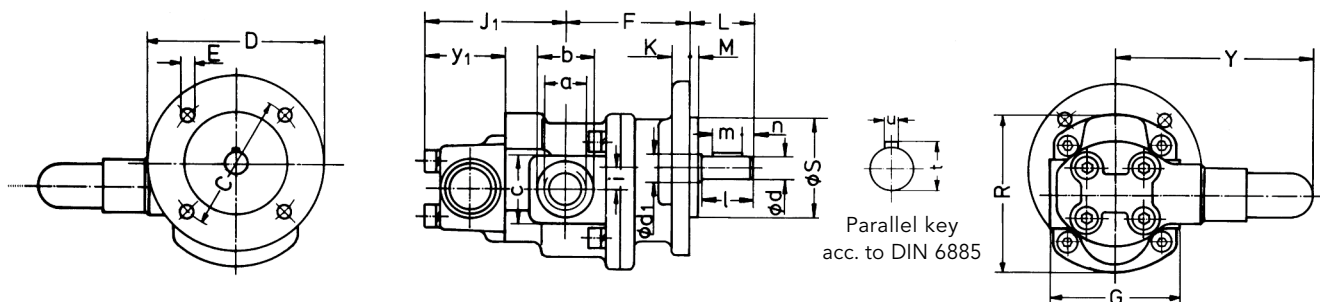

Nominal size	Inlet and outlet ports Pipe thread																Shaft end					Weight ca.			
	a	b	c	C	D	E	F	G	J ₁	K	L	M	R	S _{h6}	Y	i	y ₁	d ₁	d _{K6}	l	m	n	t	u	kg
4	G½ - 16 deep	29	40	90	110	9	64	85	70	11	40	5	100	65	132	15.5	52	16	14	30	20	5	16	5	3.80
8	G¾ - 17 deep	36					70		89																4.50
11	G¾ - 17 deep	36					70		89																4.55
16	G¾ - 17 deep	36					70		89																4.60
20	G¾ - 17 deep	36					80		89																4.90
24	G¾ - 17 deep	36					80		89																5.00

Type key

KF	1	/	4	D	1	X	K	P	0	A	0	D	E	2	/	130	+	DKF1	D	04
1	2		3	4	5	6	7	8	9	10	11	12	13	14		15		16	17	18

1 Product	
2 Size	
1	
3 Nominal size	
4 · 8 · 11 · 16 · 20 · 24	
4 Flange design	
D	Outside-Ø 110, bolt circle-Ø 90
5 Direction of rotation	
1	clockwise
2	counterclockwise
6 Mounting equipment	
X	with mounting angle
0	without mounting angle
7 Construction of housing and mounting surfaces	
K	Housing with threaded ports
8 Shaft end (Drive)	
P	Straight shaft end without outboard bearing
9 2. Shaft end (drive shaft)	
0	without 2. shaft end
10 End covers	
0	without end cover
A	for direction of rotation 1 or 2
11 Design serial no.	
	internal specified
12 Housing materials and plain bearing	
D	Cast iron with steel bearing bushes
13 Type of gear	
E	Spur gears
14 Seal	
2	FKM-radial shaft sealing for media temperatures ... 150 °C
32	PTFE-radial shaft sealing for media temperatures ... 200 °C
15 Special design no.	
130	Double shaft seal for quenching port. Bushing and gears with wear protective coating.
16 Pressure relief valve	
DKF1	Pressure relief valve for pump size 1
17 Material (Pressure relief valve)	
D	Housing GJL, seal FKM-O-ring, media temperatures ... 150 °C
C	Housing GJL, copper sealing, media temperatures ... 200 °C
18 Nominal size (Pressure relief valve)	
04	Pressure setting range: 2 ... 4 bar
08	Pressure setting range: 4 ... 8 bar
16	Pressure setting range: 8 ... 16 bar
25	Pressure setting range: 16 ... 25 bar

Technical data

I Input power

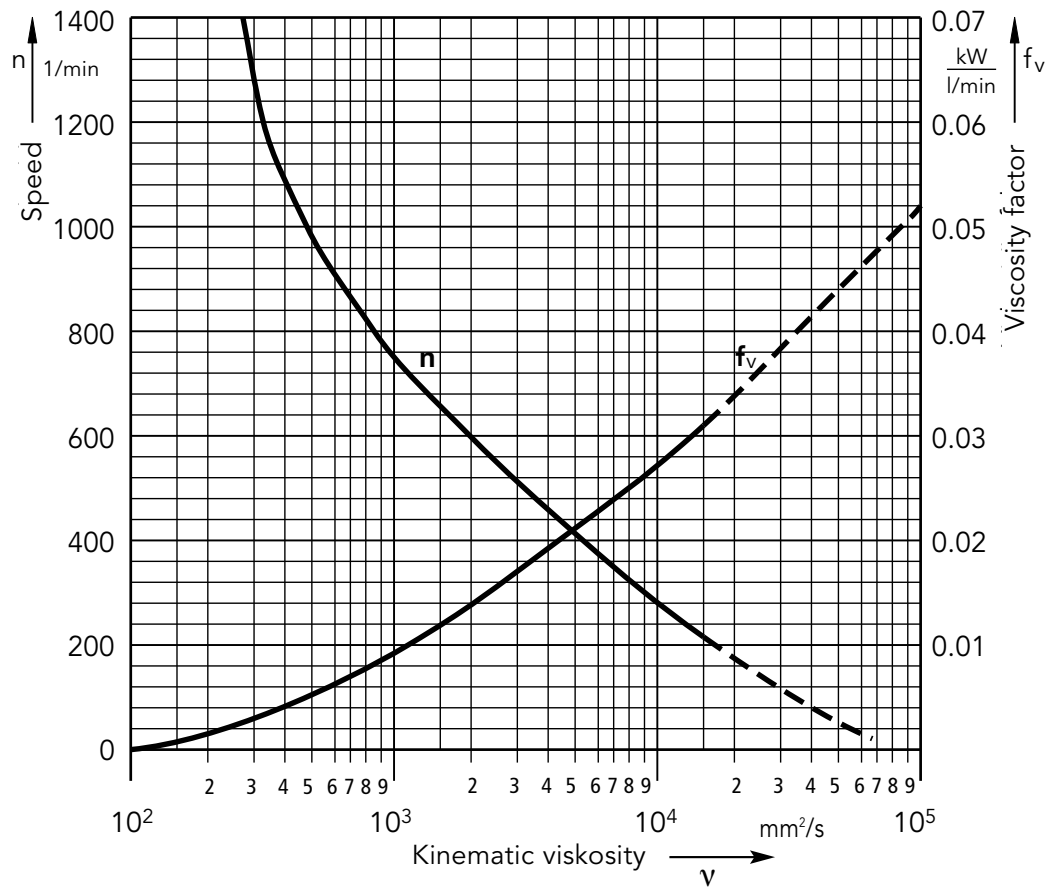

Chart: $n, f_v = f(v)$

Note:

To determine the power consumption, always take the max. operating viscosity at starting state into consideration. The power of the drive motor should be selected 20% higher than the value determined.

I Calculation of input power

Calculation / Characteristics

$$P_{1Pu} = P_{tab} \cdot \frac{n}{1450} + f_v \cdot Q$$

P_{1Pu} = Power input, pump (kW)

P_{tab} = Power input acc. to table (kW)

n = Speed (1/min)
Observe dependance of viscosity

f_v = Viscosity factor $\left[\frac{\text{kW}}{\text{l/min}} \right]$
see chart

Q = Discharge flow (l/min) with $Q = \frac{V_g \cdot n}{1000}$

V_g = Geometrical displacement (cm³/rev)

Sample calculation: Pump type KF 1/24

Viscosity $v = 3000 \text{ mm}^2/\text{s}$

Operating pressure $p = 18 \text{ bar}$

with $P_{tab} = 1.3 \text{ kW}$

$n = 500 \text{ 1/min}$

$f_v = 0.017 \frac{\text{kW}}{\text{l/min}}$

$Q = 34 \text{ l/min}$

then

$$P_{1pu} = \left(1.3 \cdot \frac{500}{1450} + 0.017 \cdot 34 \right) \text{ kW}$$

$$P_{1Pu} = 1.03 \text{ kW}$$

$$\text{Motor power output: } P_{2Mot} = 1.2 \cdot P_{1Pu} = 1.24 \text{ kW}$$

Select helical geared motor

Size 100 L with $P = 1.5 \text{ kW}$

$n = 490 \text{ 1/min}$

Technical data

I Characteristic curves

KF 1/4 ... E

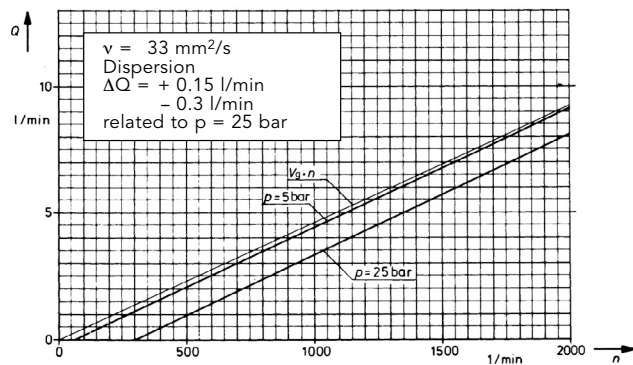

KF 1/8 ... E

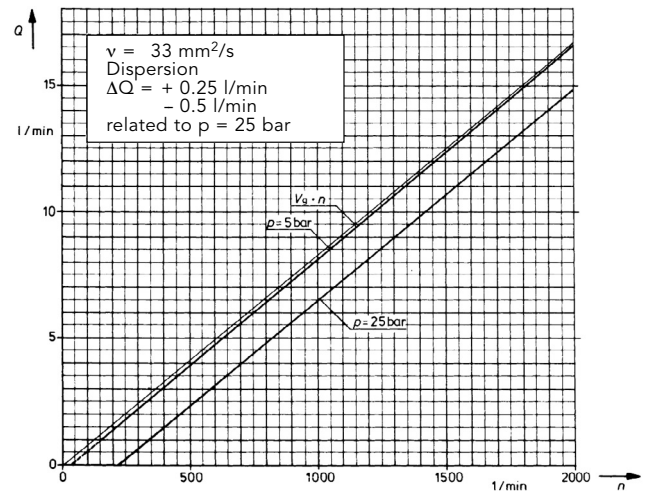

KF 1/11 ... E

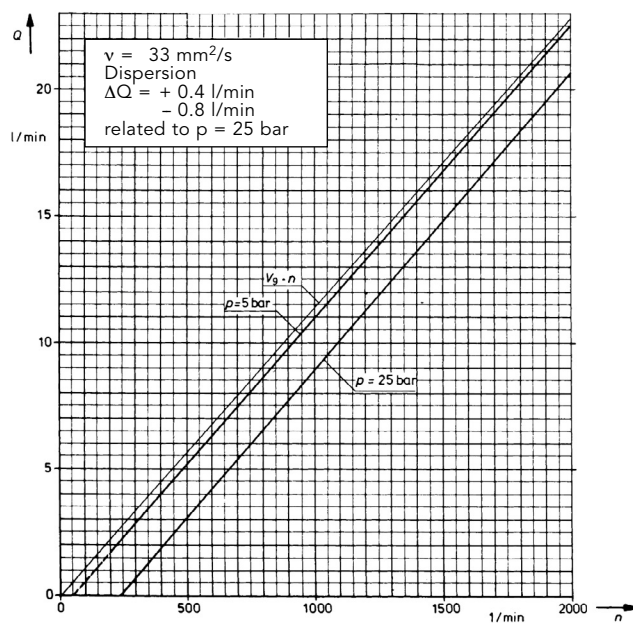

KF 1/16 ... E

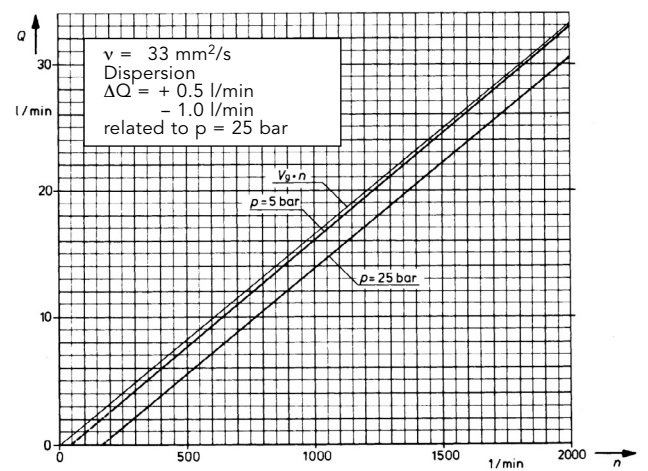

Technical data

I Characteristic curves

KF 1/20 ... E

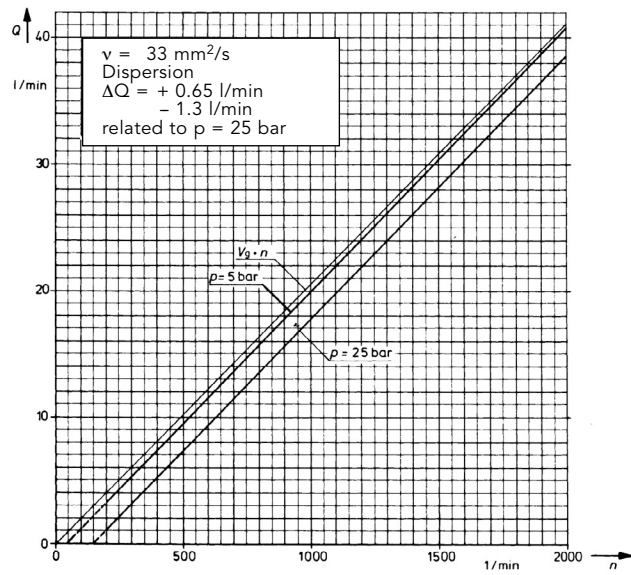

KF 1/24 ... E

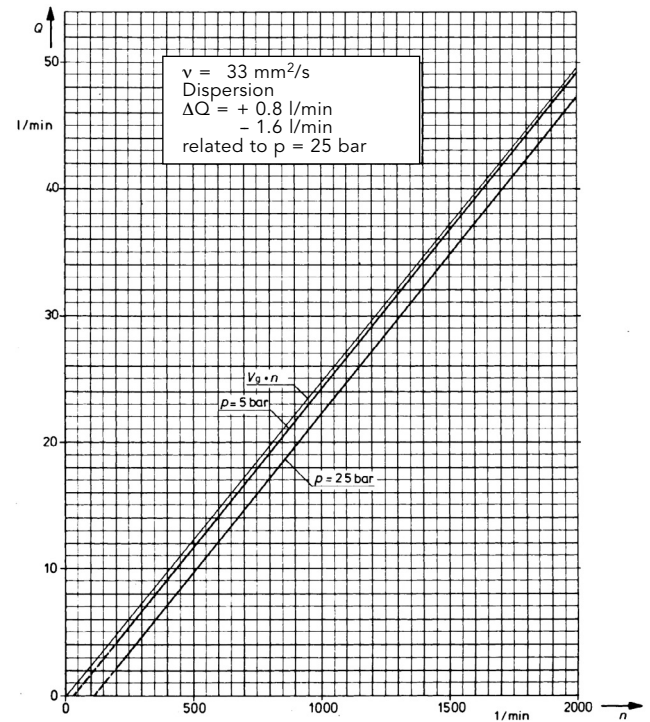

KRACHT[®]

KRACHT GmbH · Gewerbestrasse 20 · 58791 Werdohl, Germany
Phone +49 2392 935 0 · E-Mail info@kracht.eu · Web www.kracht.eu