

Pressure valves
DV



KRACHT®
FLUID TECHNOLOGY AND SYSTEMS

Content

Description / Product characteristics	4
DV B Pressure relief valve – Function / Construction / Circuit symbols / Application example	5
DV R Pressure control valve – Function / Construction / Circuit symbols / Application example	6
DV S Pressure stage control valve – Function / Construction / Circuit symbols / Application examples	7 - 8
Technical datas	9
Type key	10
p-Q Characteristic curves	11
Dimensions / Weights	12 - 15

General

I Description

The DV pressure valves are hydraulically pilot-controlled valves. They comprise a main valve and one or several pilot-controlled valves. The modular design permits using different pilot control valves which means a multitude of functions can be implemented. Along with pressure limiting and pressure control functions, this also includes special solutions such as pressure range switching valves and valves with electric relief. Typical application areas are oil hydraulics and lubrication technology.

I Product characteristics

- Pilot-controlled pressure valves for large volume flows of up to 1800 l/min
- Wide functionality through modular construction
- Supplied standard with outlet port measurement connector M
- External control-oil regulation connector X (e. g. for hydraulic relief)
- Redundant pressure protection with maximum pressure limitation (optional)
- Dimensionally interchangeable with KRACHT type SPV(F) and HV(F) valves
- Marine acceptance by various classification companies on request

I DV B Pressure relief valve



I DV R Pressure control valve



I DV S Pressure stage control valve



DV B Pressure relief valve

I Function

With the valve closed, both Main pilot valve cone **1** as well as Main pilot valve cone **2** are kept in the closed position by the spring force of the return spring. As soon as the pressure exceeds the pressure set with Setscrew **3**, the pilot valve opens and the spring chamber of the main valve is relieved to Tank **T**. A pressure gradient arises between Pressure port **P** and the spring chamber and the main valve cone opens, keeping the system pressure constant. The control oil can be discharged **Y** internally or externally. A measurement connector **M** and a port for external control oil regulation **X** are provided as standard.

I Construction

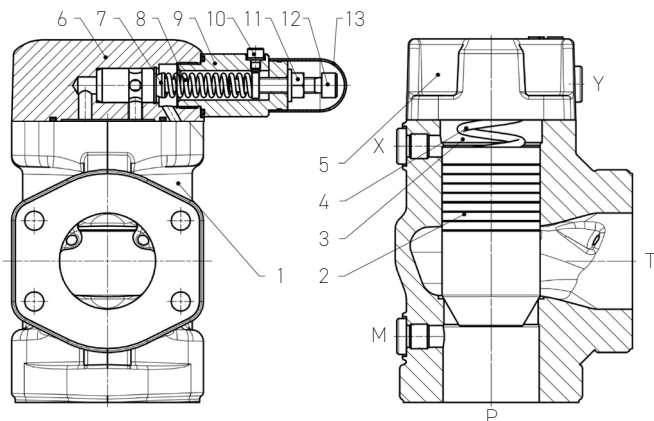

- | | |
|-------------------------------|----------------------|
| 1 Main valve | 5 Pilot valve |
| 2 Main valve piston | 6 Housing |
| 3 Spring chamber | 7 Pilot valve piston |
| 4 Compression spring | 8 Compression spring |
| M Measurement tap | 9 Cap screw |
| P Pressure port | 10 Venting screw |
| T Tank connection | 11 Union nut |
| X Control oil regulation port | 12 Adjustment screw |
| Y External control oil drain | 13 Protective cap |

I Circuit symbols

In addition, the valve is furnished with a permanently set maximum pressure relief (set-to-operate pressure = 12 bar).

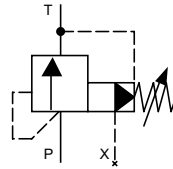

Control oil: internal drainage

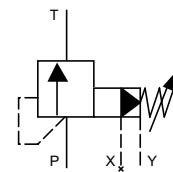

Control oil: external drainage (Y)

I Circuit symbol Option with directional valve

The DV B pressure relief valve is also available on request with an additional 2/2-directional valve (e.g. for depressurized circulation). The directional valve here is available as an open de-energised or closed de-energised version. The combination with a maximum pressure relief is not possible here.

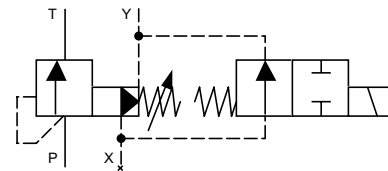

I Application example

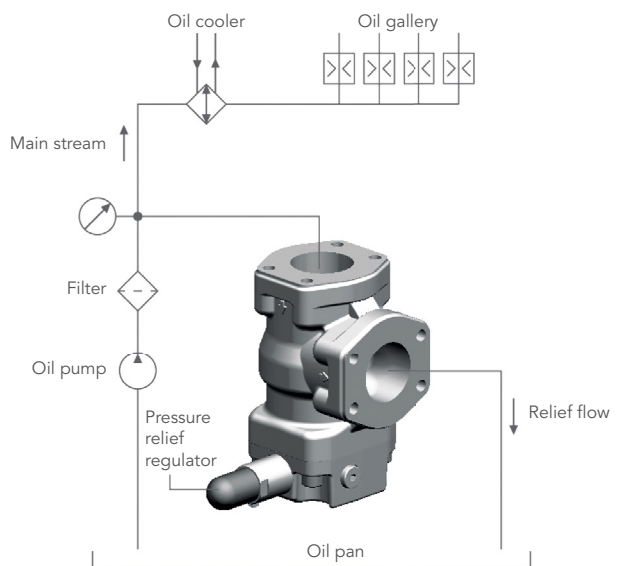

DV R Pressure control valve

I Function

The pressure control valve is a pilot-controlled pressure relief valve with external hydraulic triggering. It facilitates controlling a system pressure independent of the pressure losses between the valve and the point of the external control-oil tap. To accomplish that the pressure preset on the adjusting spindle on the connection **Z*** is kept constant.

In addition, the valve is furnished with a permanently set maximum pressure relief (set-to-operate pressure = 12 bar).

A typical application field is the pressure control of lubrication oil circuits in diesel engines.

General note:

Hydraulic counter-pressures in Connection T with internal control-oil return or in Connection Y with external control-oil return add up 1:1 to the response pressure of the valve set on the pilot control.

* see technical drawing page 13

I Construction

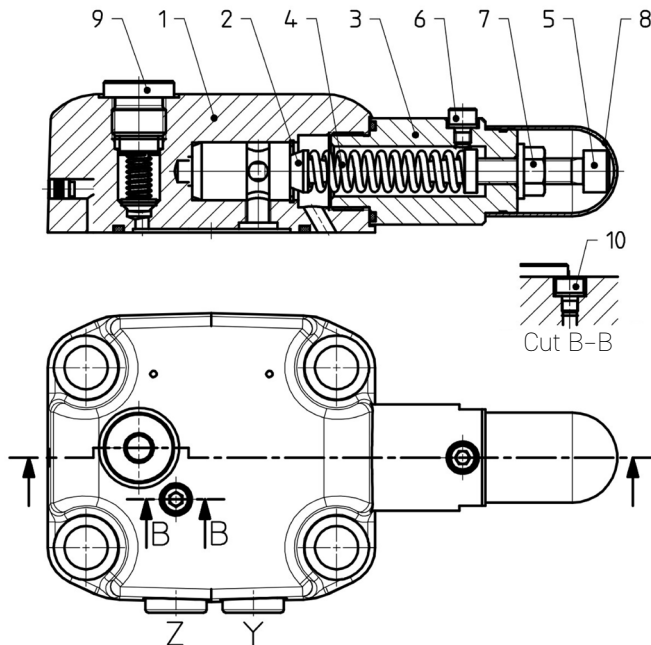

- 1 Housing
- 2 Pilot valve piston
- 3 Cap screw
- 4 Compression spring
- 5 Adjustment screw
- 6 Venting screw
- 7 Union nut
- 8 Protective cap
- 9 Max. pressure protection
- 10 Venting screw

I Circuit symbol (simplified)

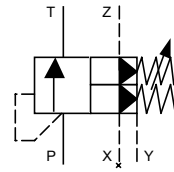

I Circuit symbol (comprehensive)

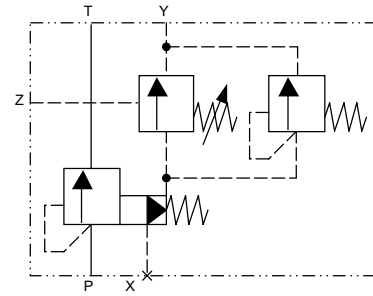

I Application example

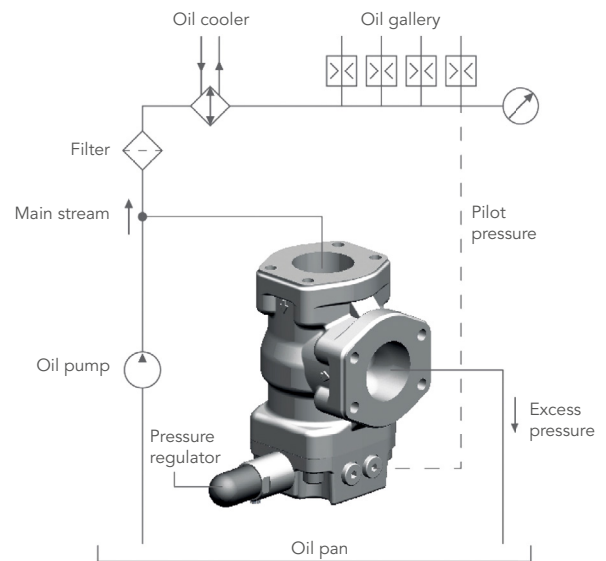

DV S Pressure stage control valve

I Function

The pressure stage control valve is a pilot-controlled pressure relief valve with two parallel switched pilot-control valves which can be set to different pressures. The basic setup corresponds to the DV B pressure relief valve. The pressure stage control valve has an integrated 2/2 directional valve in addition.

It is used to switch the low pressure stage (upstream pressure) on and off. The magnetic valve here is available as an open de-energised or closed de-energised design. The control oil drainage here can also be implemented internally or externally. A typical application field is the coupling control of ship transmissions.

I Construction pressure stage 1

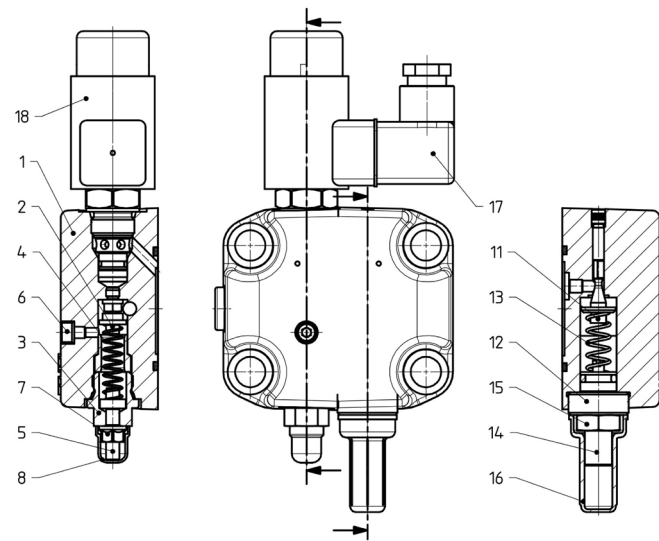

- | | |
|----------------------|-----------------------|
| 1 Housing | 11 Pilot valve piston |
| 2 Pilot valve piston | 12 Cap screw |
| 3 Cap screw | 13 Compression spring |
| 4 Compression spring | 14 Adjustment screw |
| 5 Adjustment screw | 15 Union nut |
| 6 Venting screw | 16 Protective cap |
| 7 Union nut | 17 Device plug |
| 8 Protective cap | 18 Magnet coil |

I Construction pressure stage 2

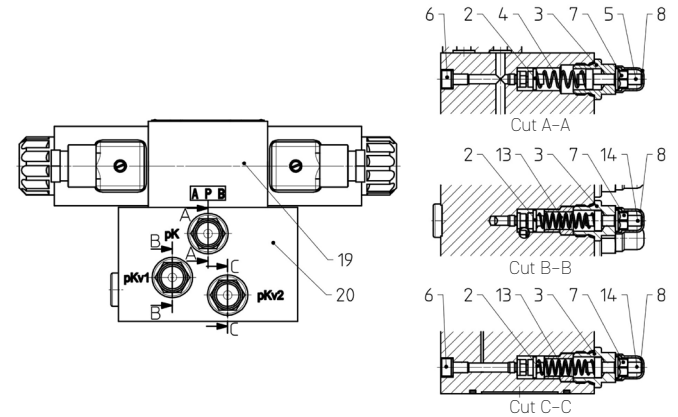

- | | |
|----------------------|-----------------------|
| 2 Pilot valve piston | 8 Protective cap |
| 3 Cap screw | 13 Compression spring |
| 4 Compression spring | 14 Adjustment screw |
| 5 Adjustment screw | 19 Directional valve |
| 6 Venting screw | 20 Valve cover |
| 7 Union nut | |

I Circuit symbols pressure stage 1

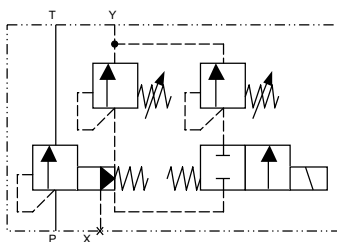

Control oil: external drainage (Y),
magnetic valve closed de-energised

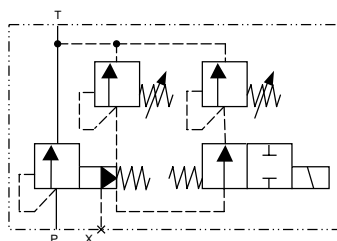

Control oil: internal drainage (Y),
magnetic valve open de-energised

I Circuit symbol pressure stage 2

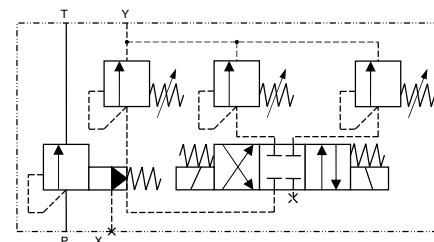

Control oil: external drainage (Y)

DV S Pressure stage control valve

I Application examples

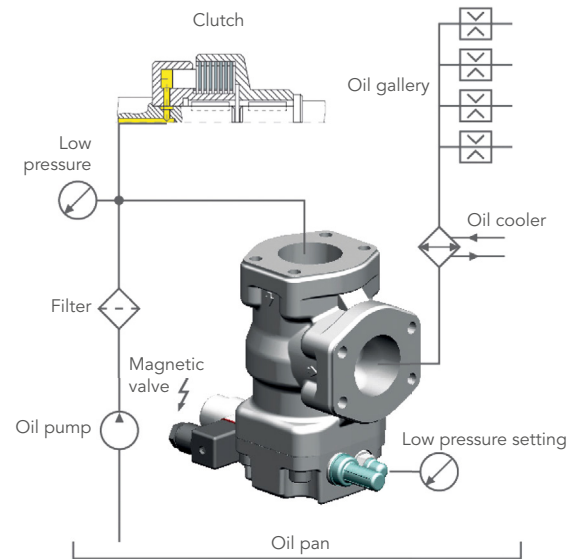
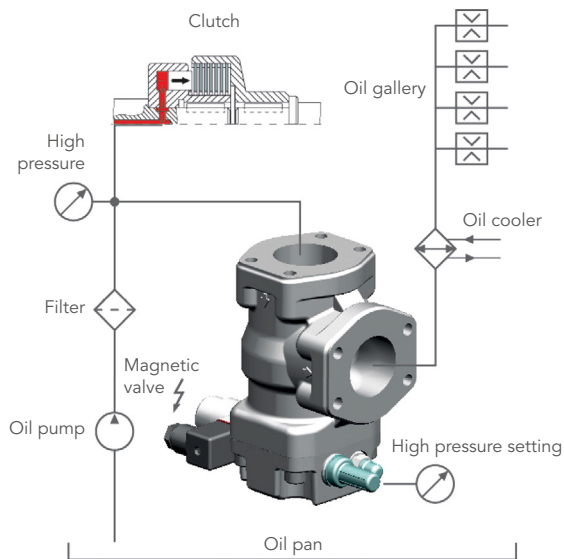

Technical data

I General characteristics

Design	Seat valve, hydraulically pilot controlled
Fixation type	Pipeline
Line connection	SAE-flange (SAE J518, code 61)
Mounting position	Optional
Type of operation	Mechanical, setscrew
Housing material	EN-GJS-400-15
Seal material	FKM, NBR
Oil purity	NAS 1638 Class 9 ISO 4406:1999 Code 20/18/15
Pressure fluids	– Hydraulic fluids as per DIN 51524/25 – Marine fuels as per DIN ISO 8217 – Motor and gearing oils – Bio-oils of type „HEES“ (Others on request)

I Hydraulic characteristics

Nominal size	50	80
Flow rate max	800 l/min	1 800 l/min
Nominal pressure	210 bar	140 bar
Viscosity	4 ... 1 000 mm ² /s	4 ... 1 000 mm ² /s
Media temperature (FKM)	-20 ... 150 °C	-20 ... 150 °C
Media temperature (NBR)	-20 ... 90 °C	-20 ... 90 °C
Ambient temperature	-20 ... 60 °C	-20 ... 60 °C

I Pressure setting ranges

Function	Pressure stage	Pressure setting ranges in bar
DV B	1	3 ... 25
	2	8 ... 70
	3	15 ... 140 (... 210 bar at nominal size 50)
	5	3 ... 12 (with maximum pressure relief 12 bar)
	1	3 ... 9 (with maximum pressure relief 9 bar)
DV R	5	3 ... 12 (with maximum pressure relief 12 bar)
	1	3 ... 10 / 10 ... 35
DV S	2	6 ... 20 / 8 ... 22 / 10 ... 30

Type key

DV	S	50	F	2	F	1	Y	A	-	NC	24	D
1	2	3	4	5	6	7	8	9		10	11	12

1 Product

2 Function

B	Pressure relief valve
R	Pressure control valve
S	Pressure stage control valve

3 Nominal size

50	Nominal width 50 resp. SAE 2"
80	Nominal width 80 resp. SAE 3"

4 Seal material

F	FKM
N	NBR

5 Material

2	Spheroidal cast iron (EN-GJS-400-15)
---	--------------------------------------

6 Connection

F	SAE-flange (SAE J518, code 61)
---	--------------------------------

7 Pressure stage

	see technical data (page 9)
--	-----------------------------

8 Control-oil drainage

Y	external
J	internal

9 Design

A	Standard design
B	Valve cover rotated 180°

10 Magnetic valve

NC	2/2-directional valve, normally closed
NO	2/2-directional valve, normally open
F	4/3-directional valve for pressure stage 2 (applies only to DV S 50)

11 Supply voltage

24	24 V DC
----	---------

12 Valve plug

D	according to DIN 43650 / ISO 440
---	----------------------------------

p-Q characteristic curves (Viscosity = 34 mm²/s)

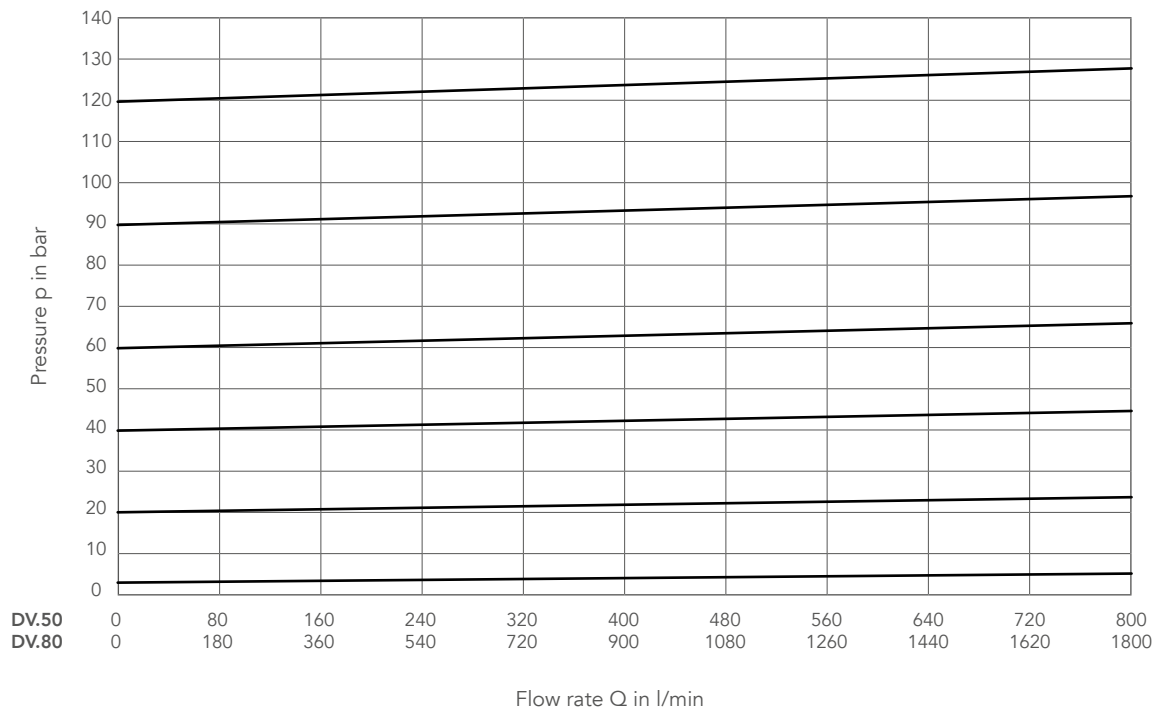
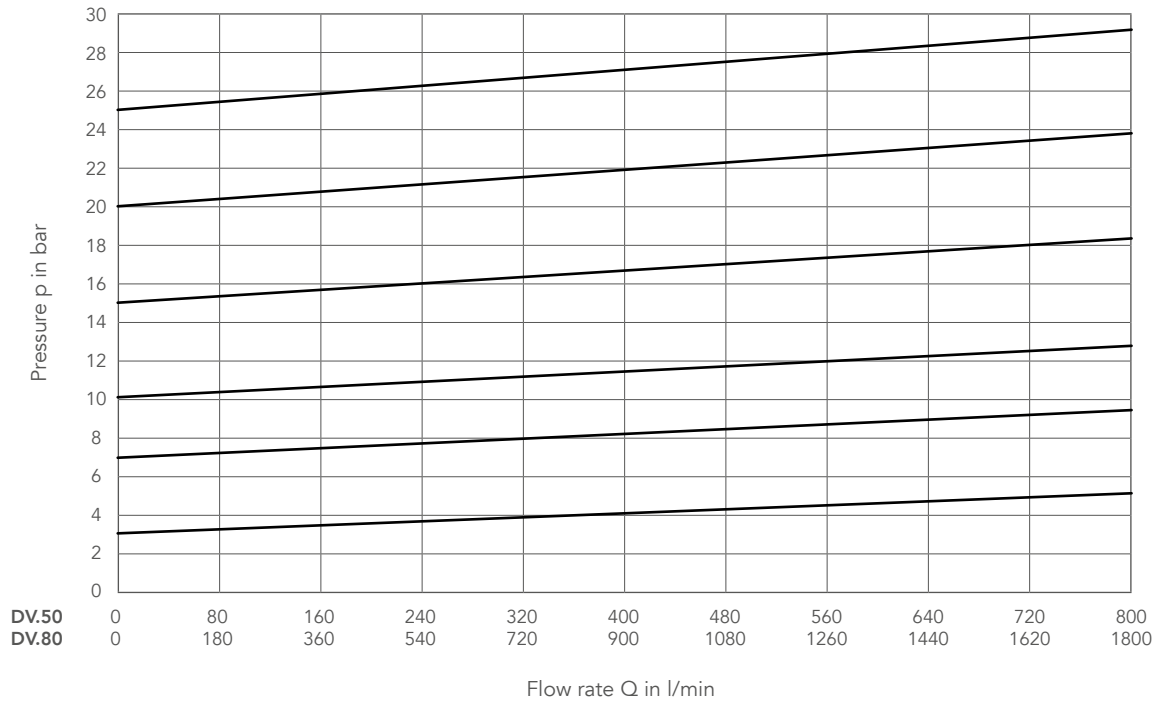

Dimensions DV B Pressure relief valve

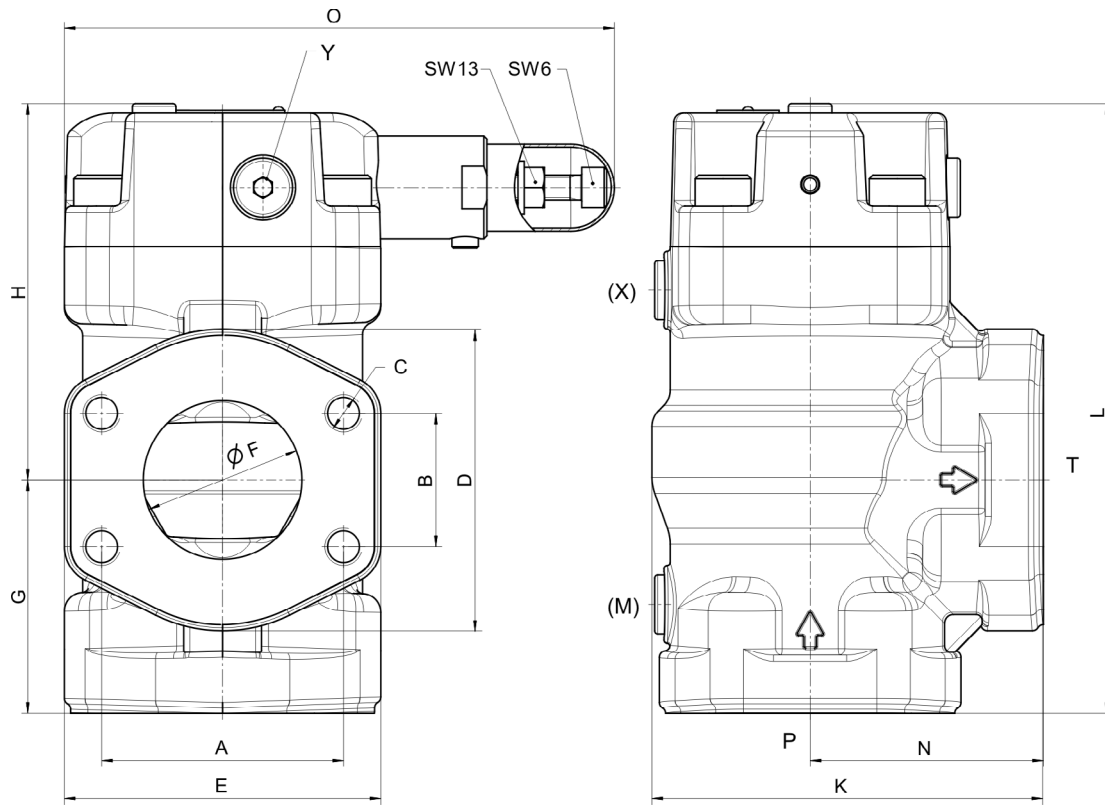

Nominal size	SAE	A	B	C	D	E	F	G	H	K	L	N	O	Weight in kg
50	2"	77.8	42.9	M12	97	102	51	75	121	126	196	75	177	9.7
80	3"	106.4	61.9	M16	131	135	76	110	151	177	261	110	209	21.2

Connections (M), (X), Y: G $\frac{1}{4}$

Connections P and T are dimensionally identical

Dimensions DV R Pressure control valve

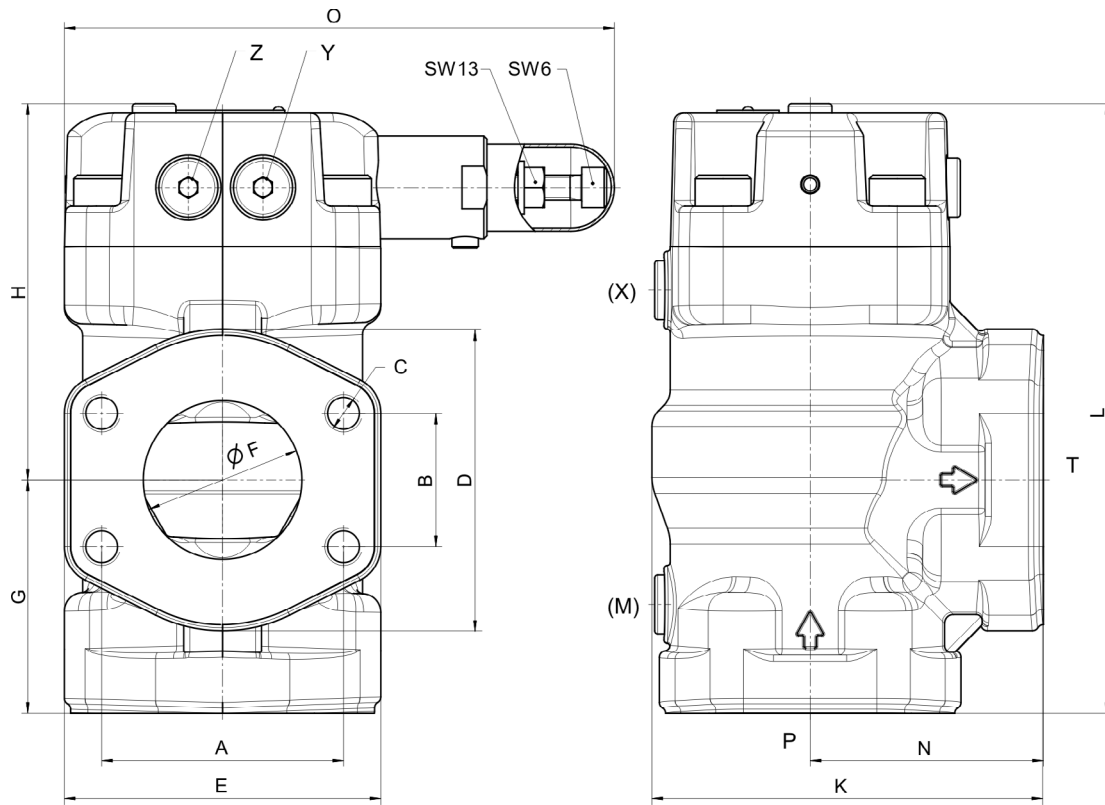

Nominal size	SAE	A	B	C	D	E	F	G	H	K	L	N	O	Weight in kg
50	2"	77.8	42.9	M12	97	102	51	75	121	126	196	75	177	9.7
80	3"	106.4	61.9	M16	131	135	76	110	151	177	261	110	209	21.2

Connections (M), (X), Y: G $\frac{1}{4}$

Connections P and T are dimensionally identical

Dimensions DV S Pressure stage control valve – Pressure stage 1

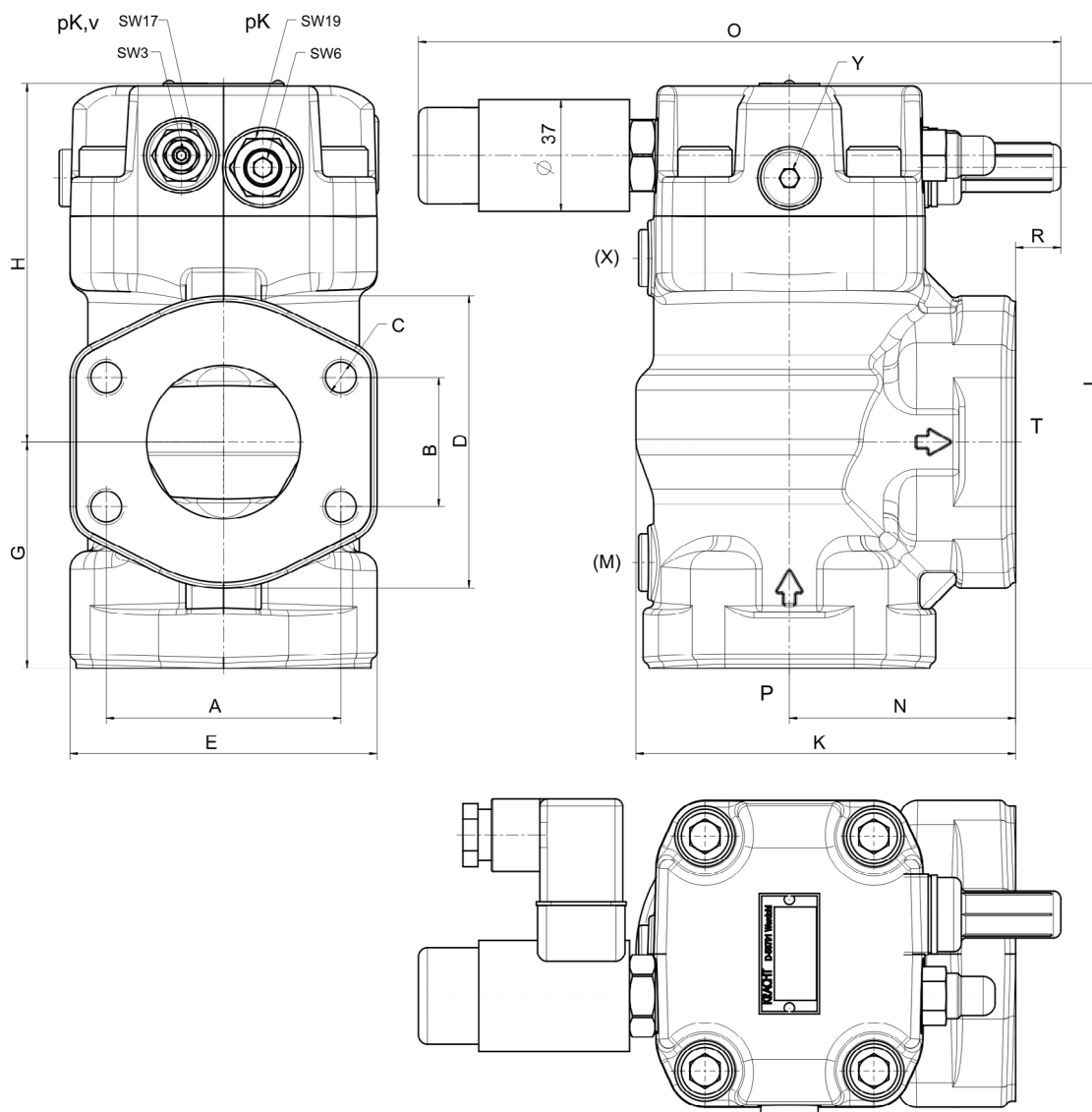

Nominal size	SAE	A	B	C	D	E	F	G	H	K	L	N	O	R	Weight in kg
50	2"	77.8	42.9	M12	97	102	51	75	119	126	194	75	213	15	9.8
80	3"	106.4	61.9	M16	131	135	76	110	149	177	259	110	240	-13*	21.4

Connections (M), (X), Y: G $\frac{1}{4}$

Connections P and T are dimensionally identical

* Dimension R: stands back 13 mm behind the edge of the object

p_K = Coupling compression (high pressure setting)

p_{KV} = Coupling supply pressure (low pressure setting)

Dimensions DV S Pressure stage control valve – Pressure stage 2

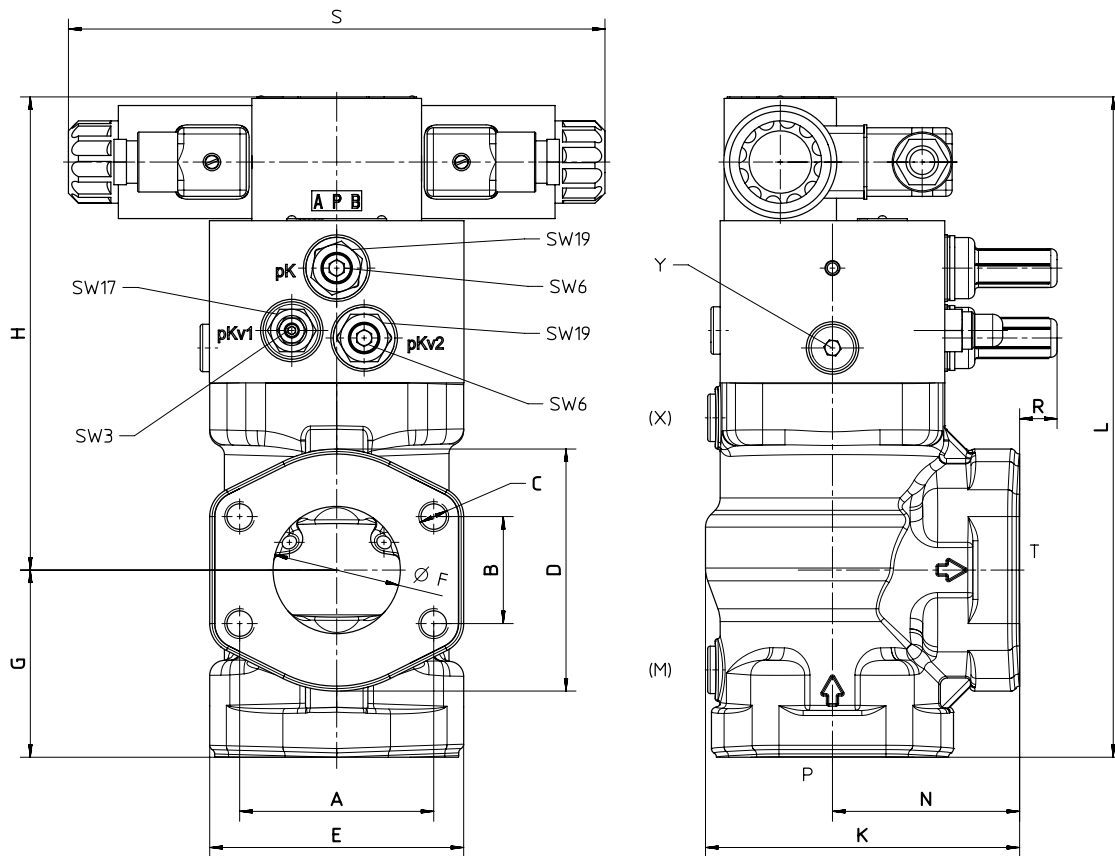

Nominal size	SAE	A	B	C	D	E	F	G	H	K	L	N	R	S	Weight in kg
50	2"	77.8	42.9	M12	97	102	51	75	180	126	265	75	15	215	13.7

KRACHT[®]

KRACHT GmbH · Gewerbestrasse 20 · 58791 Werdohl, Germany
Phone +49 2392 935 0 · E-Mail info@kracht.eu · Web www.kracht.eu