

KRACHT

D.0054330002

Operating instructions (Translation)

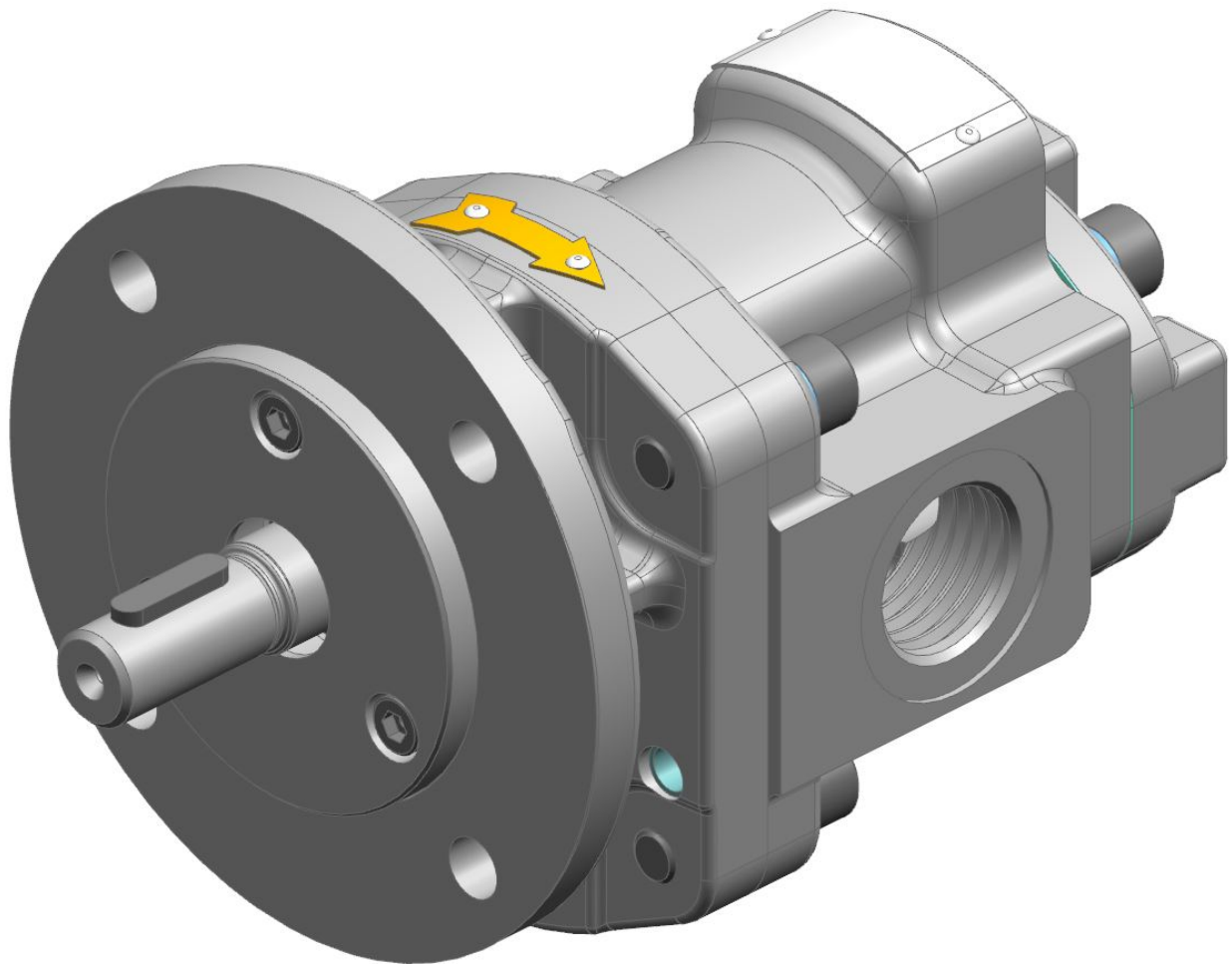

Gear pump KF 1/. ...coated
English

Table of Content

1	General	5
1.1	About the documentation	5
1.2	Manufacturer address.....	5
1.3	Applicable documents.....	5
1.4	Symbols.....	6
2	Safety.....	7
2.1	Intended use.....	7
2.2	Foreseeable misuse	7
2.3	Personnel qualification and training.....	7
2.4	Basic safety instructions.....	8
2.5	Fundamental hazards.....	8
3	Device description.....	10
3.1	Functional principle	10
3.2	Possible versions.....	11
3.3	Type key	12
3.4	Rotation and delivery direction	13
3.5	Type of seals.....	14
3.6	Special number.....	15
3.7	Free shaft end	16
3.8	Quench	16
4	Technical data.....	17
4.1	General	17
4.2	Nominal sizes.....	18
4.3	Viscosity - Rotation speed assignment.....	18
4.4	Permissible pressure range.....	19
4.4.1	Operating pressure at suction side.....	19
4.4.2	Operating pressure at pressure side	19
4.5	Permissible temperature range.....	20
4.6	Material data	21
4.7	Weight	21
4.8	Dimensions	21
5	Transport and storage	22
5.1	General	22
5.2	Transport.....	22
5.3	Storage	22
5.4	Storage conditions.....	23

6	Installation	24
6.1	Safety instructions for installation	24
6.2	Noise reduction.....	25
6.3	Mechanical installation.....	26
6.3.1	Preparation.....	26
6.3.2	Gear Pump with free shaft end.....	26
6.4	Connection lines	28
6.4.1	General.....	28
6.4.2	Suction line.....	28
6.4.3	Pressure line.....	30
6.4.4	Mounting Connection lines	30
6.5	Change of the direction of rotation.....	30
7	Operation start-up	31
7.1	Safety instructions for start-up	31
7.2	Preparation.....	31
7.3	Filling the quench chamber.....	32
7.4	Pressure relief valve adjustment.....	33
7.4.1	Pressure relief valve	33
7.5	Further operation start-up.....	34
8	Removal.....	35
8.1	Safety instructions for removal	35
8.2	Removal.....	36
9	Maintenance	37
9.1	Important notes about explosion protection	37
9.2	Maintenance work.....	38
9.3	Maintenance instructions	38
9.4	Maintenance table	39
	Maintenance table.....	39
9.4.1	Inspection: Discharge flow	40
9.4.2	Inspection: Operating pressure	40
9.4.3	Inspection: Media temperature	40
9.4.4	Inspection: Device temperature	40
9.4.5	Inspection: Add-on valve function (if existing).....	40
9.4.6	Inspection: Check the potential compensation (if existing)	40
9.4.7	Inspection: Condition of operating fluid	40
9.4.8	Audiometric monitoring: Unusual noise.....	40
9.4.9	Visual inspection: Leakages	41
9.4.10	Visual inspection: Filling level of liquid seal (if existing).....	41
9.4.11	Visual inspection: Condition gears.....	41
9.4.12	Visual inspection: Condition of housing parts.....	41
9.4.13	Visual inspection: Condition of plain bearings.....	41
9.4.14	Visual inspection: Condition of shaft seal	41
9.4.15	Replacing: Outboard bearings.....	42
9.4.16	Replacing: Plain bearings (only by manufacturer)	42
9.4.17	Replacing: Shaft seal.....	42
9.4.18	Replacing: Other seals.....	42

10 Repairs	43
10.1 Safety instructions for repair.....	43
10.2 General	44
10.3 Detecting and eliminating failures.....	45

1 General

1.1 About the documentation

These operating instructions describe the installation, operation and maintenance of the following device:

Gear pump KF 1/. - coated

These operating instructions are a component of the device and must be kept accessible for the personnel near the device at all times.

If you have any questions about these operating instructions, please contact the manufacturer.

1.2 Manufacturer address

KRACHT GmbH

Gewerbestraße 20

DE 58791 Werdohl

Tel: +49 2392 935-0

Fax: +49 2392 935-209

E-Mail: info@kracht.eu

Web: www.kracht.eu

1.3 Applicable documents

In addition to these instructions, also observe the corresponding instructions for the existing or planned systems or system parts.

1.4 Symbols



DANGER

Identification of an immediate hazard, which would result in death or severe bodily injury if not avoided.



WARNING

Identification of a potential medium risk hazard, which would lead to death or severe bodily injury if not avoided.



CAUTION

Identification of a low risk hazard, which could lead to minor or medium bodily injury if not avoided.

ATTENTION

Flagging of notices to prevent property damage.



NOTICE

Identification of basic safety instructions.
Non-compliance can lead to hazards for people and the device.



TIP

Flagging of special user tips and other especially useful or important information.

2 Safety

2.1 Intended use

1. The device has been designed for operation with fluid.
Dry operation is not permitted.
2. The product may only be operated when completely filled.
3. The fluid must be compatible with the materials used in the product. Chemical expertise is required for that. Be careful with ethylene oxide or other catalytically or exothermically reacting or self-decomposing substances. Please consult the manufacturer in cases of doubt.
4. The product may only be used in normal industrial atmospheres.
If there are any aggressive substances in the air, always consult the manufacturer.
5. The product may only be operated in compliance with these operating instructions and the applicable documents.
Deviating operating conditions require the express approval of the manufacturer.
6. Use of the product for purposes other than those for which it is intended invalidates any warranty.

2.2 Foreseeable misuse

The manufacturer is not liable for damage resulting from non-intended or improper use.

2.3 Personnel qualification and training

The personnel designated to assemble, operate and service the device must be properly qualified.

This can be through training or specific instruction.

Personnel must be familiar with the contents of this operating instructions.



NOTICE

Read the operating instructions thoroughly before use.

2.4 Basic safety instructions



NOTICE

Basic safety instructions

Non-compliance can lead to hazards for people and the unit.

- a) Follow existing regulations for accident prevention and safety at work as well as the internal regulations of the operating company.
- b) Ensure the greatest possible cleanliness.
- c) Wear suitable personal protective equipment.
- d) Do not remove type plates or other information or make them illegible or unrecognisable.
- e) Do not make any technical modifications.
- f) Comply with maintenance intervals.
- g) Only use spare parts approved by the manufacturer.

2.5 Fundamental hazards



⚠ DANGER

Hazardous fluids

Danger to life when handling hazardous fluids.

- a) Comply with the safety data sheets and regulations on handling the hazardous fluids.
- b) Collect and dispose of hazardous fluids so that no hazard is created for persons or the environment.



⚠ DANGER

Hazardous fluids

Danger to life when handling hazardous fluids.

- a) Defective components and connection lines must be replaced or fixed without delay.
- b) Use only components and connection lines approved for the expected pressure range.



⚠ DANGER

Rotating parts!

Danger of death due to body parts, hair or clothing getting trapped or entangled.

- a) Before all work, ensure that existing drives are voltage-free and pressure-free.
- b) Securely prevent restarting during all work.

**⚠ DANGER****Rotating parts**

Danger of death due to body parts, hair or clothing getting trapped or entangled.

- a) Take measures against accidental touching of rotating parts.

**⚠ WARNING****Rotating parts!**

Danger of injury from flying parts.

- a) Enclose rotating parts so as to avoid any danger from flying parts in the event of breakage or malfunction.

**⚠ WARNING****Failure of pressure bearing parts due to overload**

Risk of injury from flying parts.

Risk of injury due to splashing fluids.

- a) Depressurize the system before all work.
- b) Securely prevent the pressure from being restored during work.

**⚠ WARNING****Failure of pressure bearing parts due to overload**

Risk of injury from flying parts.

Risk of injury due to fluid spurting out.

- a) Use only connections and lines approved for the expected pressure range.
- b) Securely prevent the permissible pressures from being exceeded, e.g. by using pressure relief valves or bursting discs.
- c) Pipelines must be designed in such a way that no tension e.g. caused by changes in length due to fluctuations in temperature can be transferred to the product.

**⚠ WARNING****Failure of pressure bearing parts due to overload**

Risk of injury from flying parts.

Risk of injury due to fluid spurting out.

- a) Do not operate the product with shut-off devices closed.
- b) Securely prevent the restoration of pressure while working on the device.

3 Device description

3.1 Functional principle

Pumps of this series are external gear pump types that work according to the positive displacement principle.

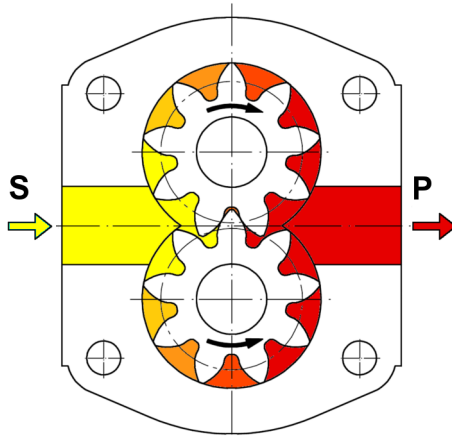

- S Suction connection
- P Pressure connection

When rotated, two gearwheels meshing together produce a volume enlargement as a result of the opening of the tooth spaces on the suction side (S), so that medium can flow in and so that a corresponding volume is displaced simultaneously by immersion of the teeth into the filled tooth spaces on the pressure side (P). Fluid transport takes place through entrainment in the tooth gaps along the wall of the wheel chamber. The so-called geometric flow rate V_g is being displaced per wheel rotation. A value that is stated in technical documents as rated volume V_{gn} to specify the pump size.

The displacement cycle describe initially takes place without exhibiting appreciable pressure build-up. Only after setting external loads, for example, through delivery heights, flow resistances, line elements, etc. will the required working pressure arise to overcome these resistances.

The pressure occurring at the shaft seal therefore corresponds to the pressure at the suction connection of the device. The permissible pressure is determined by the type of sealing.

3.2 Possible versions

Gear pump

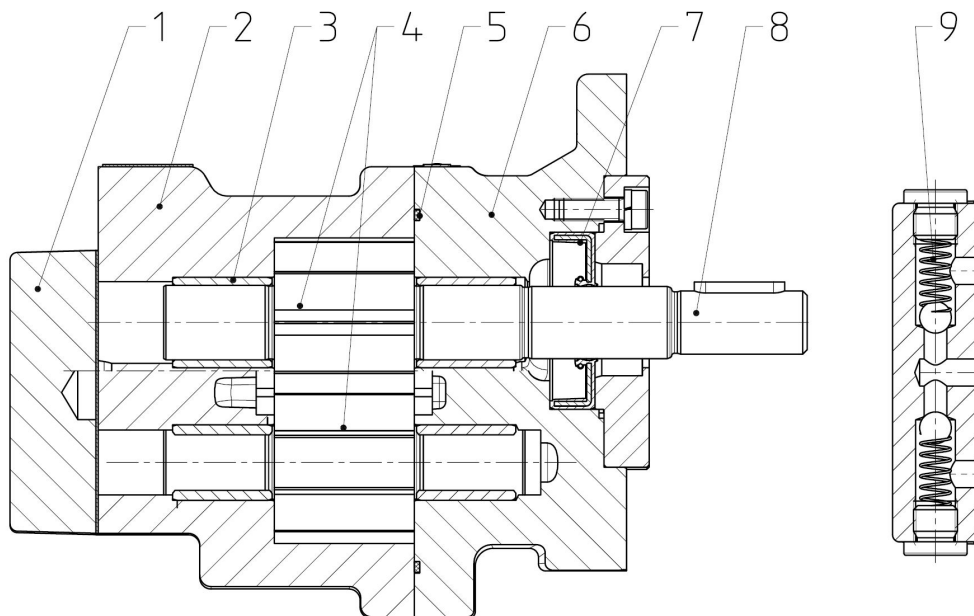

- 1 End cover
- 2 Housing
- 3 Plain bearing bush
- 4 Gears
- 5 O-ring
- 6 Flange cover
- 7 Shaft seal
- 8 End of drive shaft

(Type of seals [► 14])

- 9 Valve im End cover

(Direction of rotation : 3)

Gear pump with pressure relief valve

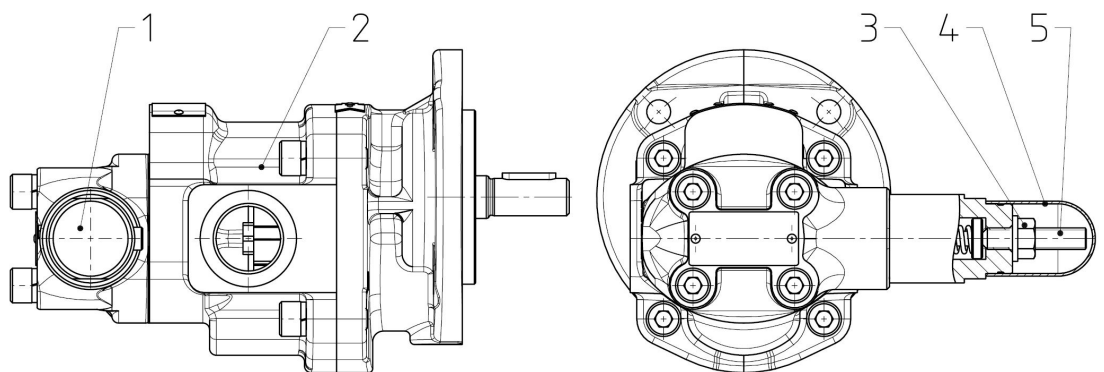

- 1 Pressure relief valve
- 2 Gear pump
- 3 Collar nut
- 4 Cover
- 5 Adjustment screw

Version cover

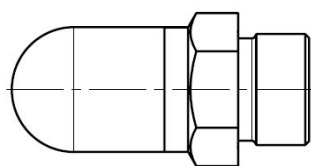

Thread protective cap

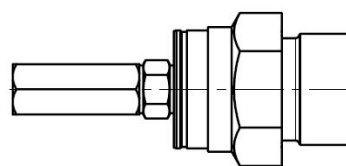

Cap nut KN17

3.3 Type key

Ordering example														
KF	1/	4	D	1	0	K	P	0	A	0	D	E	2	/130
1.	2.	3.	4.	5.	6.	7.	8.	9.	10.	11.	12.	13.	14.	15.

Ordering example			
+		DKF 1	D 04
		16.	17. 18.

Explanation of type key			
1. Product name			
2. Size			
1			
3. Nominal size			
V_{gn}	4; 8; 11; 16; 20; 24		
4. Flange mounting cover			
D	KF 1/.		
5. Direction of rotation			
1	Clockwise	3	Clockwise and counterclockwise Flow direction alternating
2	Counterclockwise		
6. Outboard flange			
X	Mounting angle	0	Without outboard bearing
7. Construction of housing			
K	Housing with threaded connection		
8. Driving shaft			
P	Cylindrical shaft end		
9. 2nd shaft end			
0	Without 2nd shaft end		
10. End cover			
A	only for only for direction of rotation 1 or 2	0	Without End cover (for valve installation)
B	only for Direction of rotation 3		
11. Design serial number (specified by manufacturer)			

Explanation of type key				
12. Housing material and plain bearing				
D	EN-GJL-250 (GG-25) Multi layer friction bearings contains lead			
13. Gears version				
E	Geom. tooth volume			
14. Seal type				
2	Rotary shaft seal FKM	32	Rotary shaft seal PTFE	
61	Without shaft seal ; O-ring FKM			
15. Special number				
Special number [▶ 15]				
16. Pressure relief valve				
DKF 1	for KF 1/.			
17. Version DKF-valve				
C	Housing material : EN-GJL-250 (GG-25)		Housing material : EN-GJL-250 (GG-25)	
	Pump side seal : Other seals O-ring Copper		Pump side seal Other seals O-ring FKM	
	Cover : Cap nut KN 17		Cover : Thread protective cap	
18. Pressure setting ranges				
04	2 – 4 bar		16	8 – 16 bar
08	4 – 8 bar		25	16 – 25 bar

3.4 Rotation and delivery direction

The direction of rotation is indicated by the bent arrow, Looking at the end of drive shaft.
The flow direction is indicated by the straight arrows.

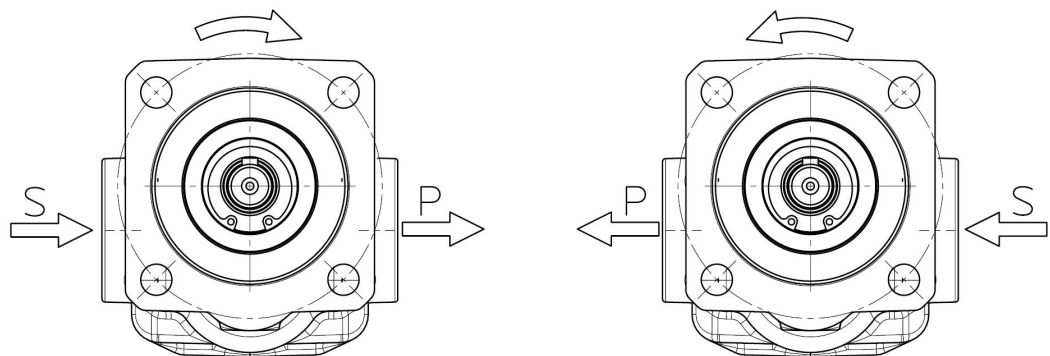

S = Suction connection
P = Pressure connection

3.5 Type of seals

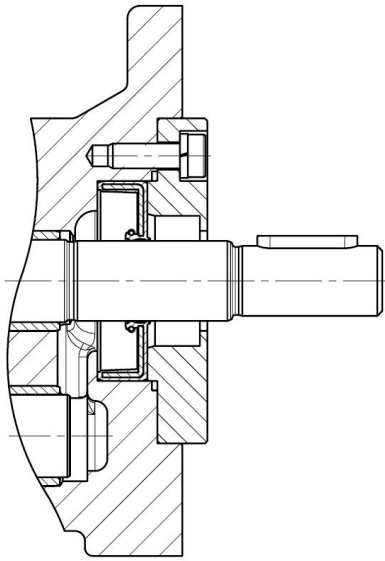

Rotary shaft seal
Special number 100
Seal type : 2; 32

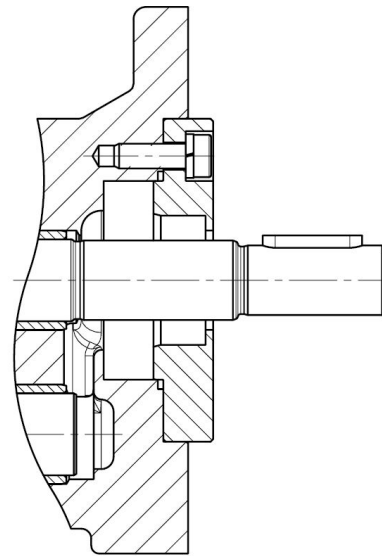

Without Shaft seal
(Leak oil drain through
shaft sealing chamber)
Special number : 456
Seal type : 61

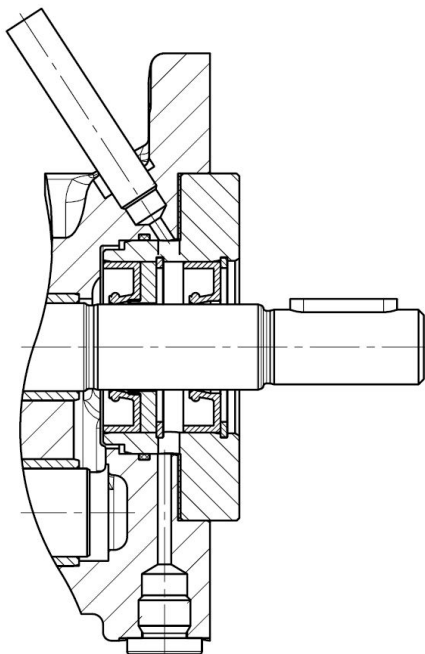

Double rotary shaft seal
Connecting pipe 8x1 (for fluid buffer)
Special number : 130; 162; 223; 224; 294; 323
Seal type : 2; 32

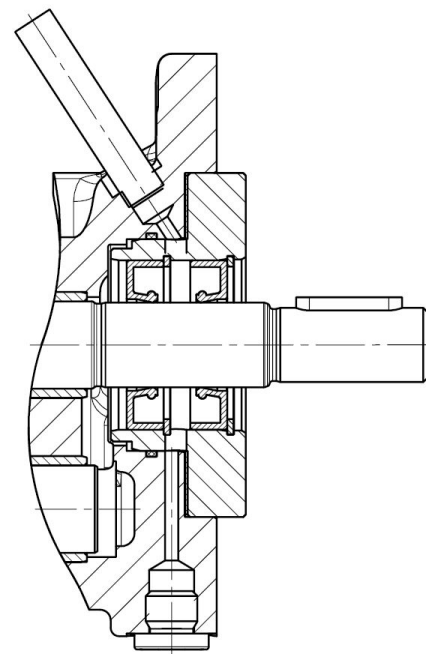

Rotary shaft seal (for vacuum operation)
Connecting pipe 8x1 (for fluid buffer)
Special number 242
Seal type : 2

3.6 Special number

Special number	Description
100	Wear protection coating on gear and plain bearing bush (Chem. nickel-plated with SiC deposits)
130	Double rotary shaft seal + Special number 100
162	Special number 130 Gears with reduced lateral clearance
223	Special number 130 Gears with reduced lateral clearance
224	Special number 130 Gears with reduced lateral clearance
242	Double rotary shaft seal for vacuum operation + Special number 100
294	Special number 130 Flange cover and enclosure nitrocarburized
323	Special number 294 Gears with reduced lateral clearance
325	Special number 294 For vacuum operation Gears with reduced lateral clearance with grease filling, Connection for fluid buffer sealed
456	Special number 100 Without shaft seal Gears with reduced lateral clearance

3.7 Free shaft end

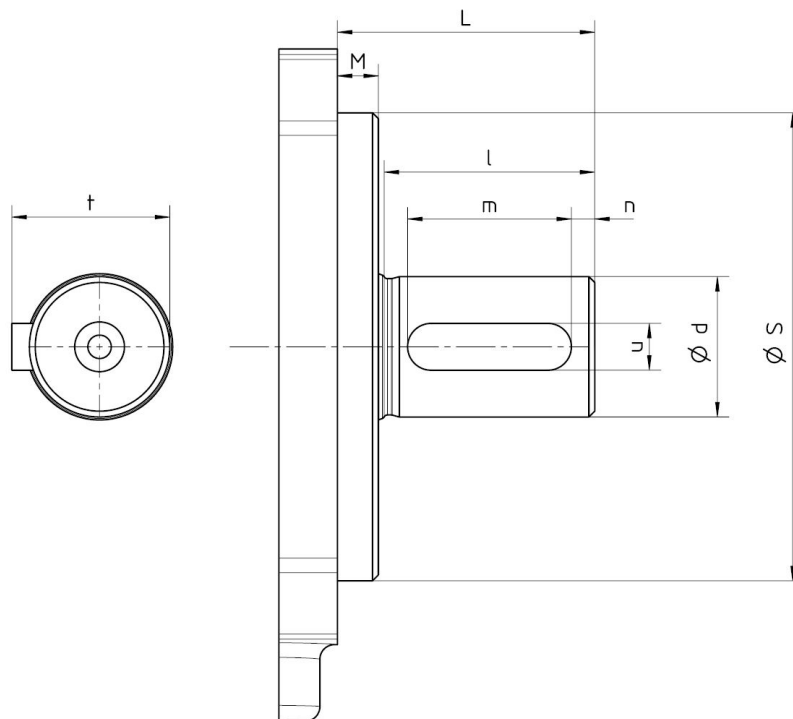

Nominal size	L	S _{h6}	M	d _{j6}	l	m	n	t	u
KF 1/4 - KF 1/24	40	65	5	14	30	20	5	16	5

3.8 Quench

Versions with quench are used when absolute leak tightness is required on the shaft seal, e.g. when pumping media

- which cures upon contact with air.
- which crystallises upon contact with air humidity.
- the leakage of which must not be released into the environment.
- are under vacuum and their seal shall be gastight.

Select the mounting position so that the connection for the quench faces up.

4 Technical data

4.1 General

General information		
Housing connection ⁽¹⁾	KF 1/4	Whitworth pipe thread G 1/2
	KF 1/8 - KF 1/24	Whitworth pipe thread G3/4
Mounting position	KF 1/ Without fluid buffer	Any
	KF 1/ with fluid buffer	Shaft end horizontal , fluid buffer connection top
External loads on shaft end		Axial and radial forces are not allowed.
Speed	n	Viscosity - Rotation speed assignment [▶ 18]
Operating pressure	p_e	Permissible pressure range [▶ 19]
	p_b	
Viscosity	v_{min}	12 mm ² /s
	v_{max}	Consult the manufacturer
Fluid temperature	ϑ_m	Permissible temperature range [▶ 20]
Ambient temperature	ϑ_u	Permissible temperature range [▶ 20]
Filtering	β	≤ 60 μm
Material	Material data [▶ 21]	
Permissible media	Fluids with abrasive components Lubricating fluids without abrasive components Example : PUR components, plasticizers, resins, adhesives, varnishes, paints, mineral oils, synthetic oils (Petrols, solvents, etc. are not permissible)	
⁽¹⁾ Pipe thread : ISO 228-1		



TIP

A reduced service life must be expected for the shaft seal in the case of vertical installation (shaft end top).

4.2 Nominal sizes

Nominal size V_{gn}	Geom. displacement V_g [cm ³ /rev.]	Speed n		Mass inertia x 10 ⁻⁴ J [kg m ²]
		n_{min} [rpm]	n_{max} [rpm]	
KF 1/4	4.6	200	2000	0.2
KF 1/8	8.3			0.35
KF 1/11	11.3			0.45
KF 1/16	16.6			0.65
KF 1/20	20.5			0.75
KF 1/24	24.8			0.87

4.3 Viscosity - Rotation speed assignment

Kinematic viscosity ν [mm ² /s]	Recommended rpm n [rpm]
200	20000
250	15000
300	10000
450	6000
650	3000
800	2000
1200	1000
1800	500
2000	400



TIP

Select the speed of rotation so that complete filling of the pump is ensured. This is given if the pressure on the suction side does not fall below the permissible pressure $p_{e.min}$.

4.4 Permissible pressure range

4.4.1 Operating pressure at suction side

Seal type	Special number	Operating pressure	
		suction side	
		$p_{e\ min}$ [bar abs.]	$P_{e\ max}$ [bar rel.]
2	-	0.6 ⁽¹⁾	1
	242	0.1	0.2
32	-	0.6 ⁽¹⁾	0.5
	325	0.1	0.2
61	456	0.6 ⁽¹⁾	Operating pressure at pressure side [► 19]

⁽¹⁾ Start-up condition: 0.4 bar absolute (max. 30 minutes)

4.4.2 Operating pressure at pressure side

Nominal size V_{gn}	Operating pressure	
	pressure side	
	p_b [bar] (perm. continuous pressure)	$p_{b\ max}$ [bar] (Maximum pressure) ⁽¹⁾
KF 1/4	50	60
KF 1/8		
KF 1/11		
KF 1/16		
KF 1/20		
KF 1/24		50

⁽¹⁾ Maximum pressure: only applicable when using mineral oil at speeds of > 700 1/min and viscosity values of 30 mm²/s - 1000 mm²/s.

4.5 Permissible temperature range

Sealing material	Fluid temperature ϑ_m	
	$\vartheta_{m \min}$ [°C]	$\vartheta_{m \max}$ [°C]
CR	-20	100
EPDM		120
FEP with FKM-core		200
FFKM / FEP with FKM-core		200
FKM		150
HNBR		90
NBR		200
PTFE / FEP with FKM-core		200
FKM (Low temperature)	-30	150

Sealing material	Ambient temperature ϑ_u	
	$\vartheta_{u \min}$ [°C]	$\vartheta_{u \max}$ [°C]
CR	-20	60
EPDM		
FEP with FKM-core		
FFKM / FEP with FKM-core		
FKM		
HNBR		
NBR		
PTFE / FEP with FKM-core		
FKM (Low temperature)	-30	



NOTICE

Comply with media-specific properties

4.6 Material data

Seal type	Material				
	Shaft seal	Other seals	Housing/ End cover	Gears	Bearing
2	FKM	FKM , C4400	EN-GJL-250 (GG-25)	Case- hardened steel (Steel 1.7139) chem. nickel with SiC de- posits	ETG 100 chem. nickel with SiC de- posits
32	PTFE	FEP with FKM-core , C4400			
61	-	FKM			

4.7 Weight

Nominal size V_{gn}	Gear pump [kg]		Added weight [kg]
	Mit End cover	Mit DKF-valve	Mounting angle
KF 1/4	3.0	3.8	0.5
KF 1/8	3.7	4.5	
KF 1/11	3.8	4.6	
KF 1/16			
KF 1/20	4.1	4.9	
KF 1/24	4.2	5.0	

4.8 Dimensions

Dimensions of the device can be found in the relevant technical data sheets.

5 Transport and storage

5.1 General

- a) After receipt, check the device for transport damages.
- b) If transport damage is noticed, report this immediately to the manufacturer and the carrier. The device must then be replaced or repaired.
- c) Dispose of packing material and used parts in accordance with the local stipulations.

5.2 Transport



WARNING

Falling or overturning loads!

Danger of injury while transporting large and heavy loads.

- a) Use only suitable means of conveyance and lifting tackle with sufficient load-bearing capacity.
- b) Attach lifting tackle only to suitable load points.
- c) Attach the lifting tackle in such a manner that it cannot slip.
- d) Pay attention to the load balance point.
- e) Always avoid jerks, impacts and strong vibrations during transportation.
- f) Never walk under suspended loads, never work under suspended loads.



NOTICE

To transport the device , eyebolts can be screwed into the flange connections..

5.3 Storage

The device's function is tested in the plant with mineral hydraulic oil. Then all connections are closed. The remaining residual oil preserves the interior parts for up to 6 months.

Metallic exposed exterior parts are protected against corrosion by suitable conservation measures, also up to 6 months.

In case of storage, a dry, dust-free and low-vibration environment is to be ensured. The device is to be protected against influences from weather, moisture and strong fluctuations of temperature. The recommended storage conditions are to be adhered to.

Below the permissible ambient temperature ϑ_U elastomer seals lose their elasticity and mechanical loading capacity, since the glass transition temperature is fallen below. This procedure is reversible. A force action on the device is to be avoided in case of storage below the permissible ambient temperature ϑ_U .

Devices with EPDM seals are not mineral-oil resistant and are not tested for their function. There is no preservation of the interior parts. If the device is not taken into operation immediately, all corrosion-prone surfaces are to be protected by suitable conservation measures. The same applies for devices which are not tested for other reasons

When storing for a long period of time (> 6 months), treat all surfaces at risk of corrosion again with suitable preserving agents.

If high air humidity or aggressive atmospheres are expected, take additional corrosion-preventing measures.



NOTICE

Storage in corrosion protection bags (VCI) maximum of 6 months.

⚠ ATTENTION

Corrosion/chemical impact

Improper storage can render the device useless.

- a) Protect endangered surfaces by means of suitable conservation measures.
- b) Comply with recommended storage conditions.

5.4 Storage conditions



TIP

Recommended storage conditions

- a) Storage temperature: 5 °C – 25 °C
- b) Relative air humidity: < 70 %
- c) Protect elastomer parts from light, especially direct sunlight.
- d) Protect elastomer parts from oxygen and ozone.
- e) Comply with maximum storage times of elastomeric parts:
 - ⇒ 5 Years: AU (Polyurethane rubber)
 - ⇒ 7 Years: NBR, HNBR, CR
 - ⇒ 10 Years: EPM, EPDM, FEP/PFTE, FEPM, FKM, FFKM, VMQ, FVMQ

6 Installation

6.1 Safety instructions for installation



⚠ DANGER

Hazardous fluids

Danger to life when handling hazardous fluids.

- a) Comply with the safety data sheets and regulations on handling the hazardous fluids.
- b) Collect and dispose of hazardous fluids so that no hazard is created for persons or the environment.



⚠ DANGER

Rotating parts!

Danger of death due to body parts, hair or clothing getting trapped or entangled.

- a) Before all work, ensure that existing drives are voltage-free and pressure-free.
- b) Securely prevent restarting during all work.



⚠ DANGER

Rotating parts

Danger of death due to body parts, hair or clothing getting trapped or entangled.

- a) Take measures against accidental touching of rotating parts.



⚠ WARNING

Rotating parts!

Danger of injury from flying parts.

- a) Enclose rotating parts so as to avoid any danger from flying parts in the event of breakage or malfunction.



⚠ WARNING

Unshielded gearwheels

Gearwheels can trap and crush fingers and hands.

- a) Do not engage gearwheels.

**⚠ WARNING****Failure of load-carrying parts due to overload!**

Danger of injury from flying parts.
Danger of injury from spurting fluids.

- a) Depressurise the device and all connection lines before doing any work.
- b) Securely prevent the restoration of pressure while working on the device.

**⚠ WARNING****Failure of pressure bearing parts due to overload**

Risk of injury from flying parts.
Risk of injury due to fluid spurting out.

- a) Use only connections and lines approved for the expected pressure range.
- b) Securely prevent the permissible pressures from being exceeded, e.g. by using pressure relief valves or bursting discs.
- c) Pipelines must be designed in such a way that no tension e.g. caused by changes in length due to fluctuations in temperature can be transferred to the product.

6.2 Noise reduction

**TIP****Measures for noise reduction**

- a) Use suction and pressure hoses.
- b) Use bell housings with high damping properties (plastic or cast iron).
- c) Use of damping rings and damping rods for separation of structureborne noise.

6.3 Mechanical installation

6.3.1 Preparation

- a) Check the device for transport damage and dirt.
 - b) Check the device for freedom of movement.
 - c) Remove existing preservatives.
 - ⇒ Use only those cleaning agents that are compatible with the materials used in the device.
 - ⇒ Do not use cleaning wool.
 - d) Compare the environmental and ambient conditions at the place of installation to the permissible conditions.
 - ⇒ Ensure a sufficiently stable and level foundation.
 - ⇒ Expose the device only to small vibrations, see IEC 60034-14.
 - ⇒ Secure sufficient access for maintenance and repair.
 - e) Position the product and secure them against slipping.
 - ⇒ Comply with the manufacturer's information.
 - ⇒ Do not use any sealing materials such as hemp, Teflon tape or putty.
-

6.3.2 Gear Pump with free shaft end

The prerequisite for trouble-free operation is suitable load transmission between the pump and the drive.

By default a torsionally flexible claw coupling is used for this.

-
- a) Pre-mount coupling parts as per manufacturer's specifications.
 - b) Position the pumps and the drive with respect to each other.
 - ⇒ Comply with the permissible mounting position.
 - ⇒ Comply with the permissible direction of rotation.
 - c) Tighten all fastening screws with the specified torque.
-



DANGER

Rotating parts

Danger of death due to body parts, hair or clothing getting trapped or entangled.

- a) Take measures against accidental touching of rotating parts.
-



CAUTION

Hot surfaces

Burn injury to skin if touched.

- a) Wear protective gloves at temperatures $\geq 48^{\circ}\text{C}$.

Tightening torques [Nm]							
Thread size	M6	M8	M10	M12	M16	M20	M24
Counter-thread Aluminium	4.6	11	22	39	95	184	315
Counter-thread Cast iron / Steel	10	25	49	85	210	425	730

⁽¹⁾ Screws/Nuts with min. strength class 8.8/8



TIP

- a) Keep to the permissible displacement values of the coupling.
- b) Rule out any distortion of the device.
- c) Pay attention to sufficient screw-in depth of the fastening screws.



NOTICE

- a) For devices without shaft seals, ensure that the leak oil from the shaft sealing chamber is specifically drained off and cannot get into the environment.
- b) Make sure no foreign bodies can get into the device.
- c) On devices with quench, mount a tank for the liquid seal.
 - ⇒ Mount the tank above the device.
 - ⇒ The connection on the device must point upward.
 - ⇒ Checking the fluid level must be possible at any time.

6.4 Connection lines

6.4.1 General



WARNING

Failure of load-carrying parts due to overload

Danger of injury from flying parts..
 Danger of injury from spurting fluids.

- a) Use only connections and lines approved for the expected pressure range.
- b) Securely prevent exceeding the permissible pressure, e.g. by using pressure relief valves or rupture discs.
- c) Design pipework so that no tensions, e.g. caused by changes in length due to fluctuations in temperature, are transmitted to the device.



NOTICE

Additional connections

- a) Provide measurement connections for pressure and temperature as close as possible to device.
- b) If necessary, provide a facility to fill or empty the device and the line system.
- c) If necessary, provide a facility to vent the device and the line system.

6.4.2 Suction line

A less than optimally planned suction line can lead to increased noise emission, cavitation as well as reduction of the delivery rate (caused by not complete filling of the pump).

When designing the line, take the following points into consideration:

The suction line must be piped as short as possible and in a straight line.

- Stipulate the nominal width of the suction line so that the permissible operating pressure $p_{e, \min}$ is not exceeded on the suction side.
- Avoid large suction heights.
- Avoid additional pressure loss through line resistances such as fittings, screwed connections, formed parts or suction filters/suction baskets. Ensure that all technically required suction filters/suction baskets are appropriately dimensioned.
- Make sure there is sufficient clearance of the suction port to the bottom and walls of the media container.
- Make sure that the suction opening lies underneath the lowest fluid level in all operating situations.
- When hose lines are used, ensure sufficient stability of the hoses so that they cannot become constricted through the sucking action.
- Comply with the recommended flow velocity in the suction line (max. 1.5 m/s).

Suction line at vacuum operation

If suction from a tank under vacuum is desired, the pump must be arranged approx. 1 m below the tank. The suction line must run in a straight line and without any resistances.

The tank may be subjected to vacuum only then when the pipe-work and the pump have been filled with liquid. For this application, only pumps suitable for vacuum operation may be used.

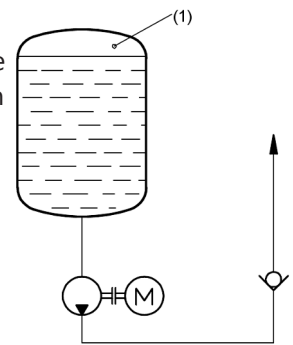

NOTICE

Cavitation damage

Undercutting the permissible suction port pressure results in cavitation.

- a) Design the suction line so that the pressure arising in operation on the suction side is always higher than the vapour pressure of the pumped medium. At the same time, comply with the installation altitude of the device above mean sea level.
- b) For aqueous fluids, mount the device underneath the fluid level, set the operating temperature to 50 °C and limit the speed to 1500 rpm.

Prevention of suction problems

If there is a possibility that the suction line can run dry if the pump stops, piping the suction line as siphon is an option to avoid suction problems. This way, the pump will remain permanently filled after initial commissioning.

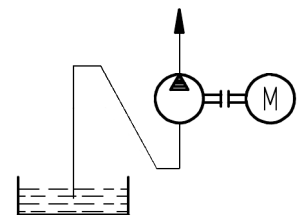

It is appropriate to employ a foot valve or a non-return valve in case of longer suction lines that can run dry while the pump is at rest. These must have been designed for use in suction lines and should offer as low a flow resistance as possible.

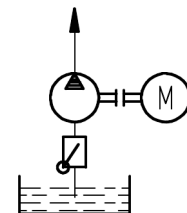

During operation of a pump that has to pump media via a non-return valve in a pressurized circuit (e.g. reserve pump in a lubricant circuit), suction problems can occur if the suction line is filled with air.

In this case the pressure pipe must be bled directly upstream of the non-return valve.

If no vent nozzle is used, the volume of the pressure pipe between the pump and the non-return valve must be at least 75 % of the suction line volume.

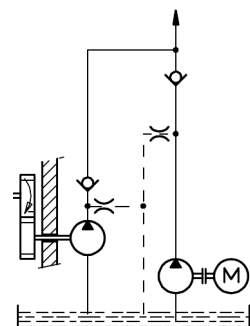

6.4.3 Pressure line

When designing the line, take the following points into consideration:

- Select the nominal width of the pressure line so that the maximum permissible pressures are not exceeded.
- If necessary, provide a vent nozzle to prevent suction problems.

6.4.4 Mounting Connection lines

- a) Clean all lines.
 - ⇒ Do not use cleaning wool.
 - ⇒ Pickle and flush welded pipes.
 - b) Remove the protective plugs.
 - c) Mount the lines.
 - ⇒ Comply with the manufacturer's information.
 - ⇒ Do not use any sealing materials such as hemp, Teflon tape or putty.
-



TIP

Position of the device connections: **Rotation and delivery direction** [▶ 13]

6.5 Change of the direction of rotation

Depending on the version a change in the direction of rotation is possible.

The manufacturer normally carries out the conversion work and the customer should do this only in exceptional cases.

7 Operation start-up

7.1 Safety instructions for start-up



DANGER

Hazardous fluids

Danger to life when handling hazardous fluids.

- a) Comply with the safety data sheets and regulations on handling the hazardous fluids.
- b) Collect and dispose of hazardous fluids so that no hazard is created for persons or the environment.



WARNING

Failure of load-carrying parts due to overload

Danger of injury from flying parts.

Danger of injury from spurting fluids.

- a) Do not operate the device against closed shut-off devices.
- b) Do not operate the device in the false direction of rotation.



CAUTION

Hot surfaces

Burn injury to skin if touched.

- a) Wear protective gloves at temperatures $\geq 48^{\circ}\text{C}$.

7.2 Preparation

- a) Before starting the product, make sure that a sufficient quantity of the service fluid is extant to avoid dry running. This must be taken into account especially with large line volumes.
- b) Check all fastening screws on the product.
- c) Fill pump and the suction line with medium.

7.3 Filling the quench chamber

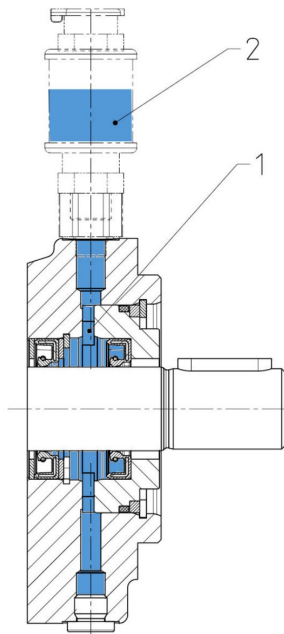

- 1 Quench chamber
- 2 Container for quench-liquid

-
- a) For versions with quench, fill the quench chamber with a suitable quench liquid.
 - ⇒ The filling is implemented through the tank provided for that.
 - ⇒ Fill fluid until the quench chamber is completely full and the tank is half full.
-



NOTICE

Seal failure due to dry run

A lack of quench liquid can lead to a failure of the seal.

- a) Do not put pumps without quench liquid into operation.
-



TIP

A second port on the unit enables purging of the quench chamber and draining of the liquid seal.

7.4 Pressure relief valve adjustment

The valves are factory set to the rated pressure of each pressure stage. Setting pressures that deviate from this are stated on the rating plate.

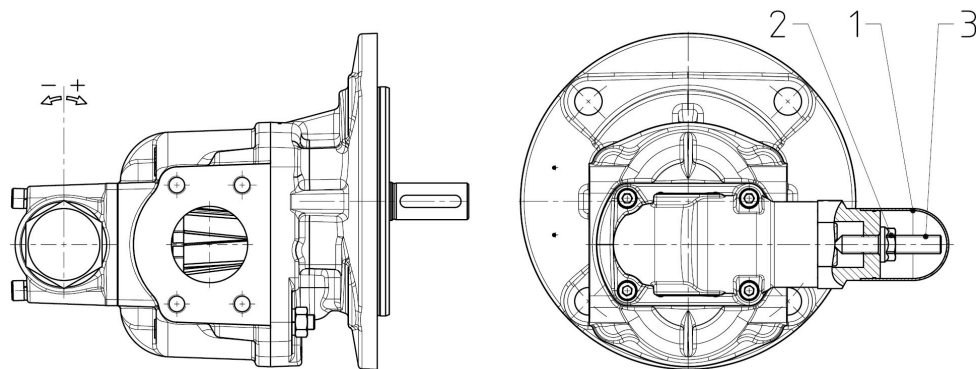

- response pressure lower
- + response pressure higher

- 1 Adjustment screw
- 2 Hexagonal nut
- 3 Cover

- a) Remove cover.
- b) Remove hexagon nut.
- c) Set the response pressure using the adjusting screw.
- d) Secure the adjusting screw with hexagon nut.
- e) Mount cover.



WARNING

Failure of load-carrying parts due to overload

Danger of injury from flying parts.
Danger of injury from spurting fluids.

- a) Consider the permissible pressure setting range of the valve.
- b) Check the pressure setting (the valve must not block).

7.4.1 Pressure relief valve

Directly attached pressure relief valves of the series "D" are used exclusively for protection of the gear pumps and may respond on a short-term basis only.



NOTICE

Failure of the pump

Long triggering of the valve can cause the pump to overheat.

- a) Only allow intermittent triggering of the valve.

7.5 Further operation start-up

- a) Open existing shut-off elements upstream and downstream of the device.
 - b) Adjust pressure relief valves in the system installed for lowest opening pressure.
 - c) Allow the device start without or with a low pressure load (jog mode).
 - ⇒ Flow should have developed after 30 s at the latest.
 - d) Run the device for a few minutes depressurised or with low pressure.
 - e) Vent the system at the highest possible point.
 - f) Gradually increase the pressure load up to the desired operating pressure.
 - g) Operate the system for so long until the final operating state is achieved.
 - h) Check the operating data.
 - ⇒ **Maintenance table** [▶ 39]
 - i) Document the operating data of the initial start-up for later comparison.
 - j) Check the level of the operating medium in the system.
 - k) Check the filling level of the liquid seal (if existing).
 - l) Check the device for leaks.
 - m) Check all threaded connections for leaks and retighten if necessary.
-



TIP

In order to ensure a constant and reliable function of the product, an initial maintenance of the product is recommended after several hours warm-up time (max. 24 h). This allows faults to be detected at an early stage.

8 Removal

8.1 Safety instructions for removal



DANGER

Hazardous fluids

Danger to life when handling hazardous fluids.

- a) Comply with the safety data sheets and regulations on handling the hazardous fluids.
- b) Collect and dispose of hazardous fluids so that no hazard is created for persons or the environment.



DANGER

Rotating parts!

Danger of death due to body parts, hair or clothing getting trapped or entangled.

- a) Before all work, ensure that existing drives are voltage-free and pressure-free.
- b) Securely prevent restarting during all work.



WARNING

Unshielded gearwheels

Gearwheels can trap and crush fingers and hands.

- a) Do not engage gearwheels.



WARNING

Failure of load-carrying parts due to overload!

Danger of injury from flying parts.

Danger of injury from spurting fluids.

- a) Depressurise the device and all connection lines before doing any work.
- b) Securely prevent the restoration of pressure while working on the device.



CAUTION

Hot surfaces

Burns of the skin on contact.

- a) At temperatures $\geq 48^{\circ}\text{C}$ the product must be allowed to cool down first.

 **ATTENTION****Blocking of the product due to curing media**

Curing media can mechanically block the product and make it unusable.

- a) Clean the product immediately after operation with curing media.

8.2 Removal

- a) Depressurise and de-energize the system.
- b) Close existing shut-off elements upstream and downstream of the device.
- c) Open existing drain elements and loosen connection lines. Collect and dispose of discharging medium so that no hazard arises for persons or environment.
- d) Dismantle the device.
- e) Clean the device
- f) Close the device connections and lines to prevent dirt penetration.

**NOTICE**

The concrete procedure for cleaning depends on the media being used.

- a) See the safety data sheet of the media in use.

9 Maintenance

9.1 Important notes about explosion protection



⚠ DANGER

Hazardous fluids

Danger to life when handling hazardous fluids.

- a) Comply with the safety data sheets and regulations on handling the hazardous fluids.
- b) Collect and dispose of hazardous fluids so that no hazard is created for persons or the environment.



⚠ DANGER

Rotating parts!

Danger of death due to body parts, hair or clothing getting trapped or entangled.

- a) Before all work, ensure that existing drives are voltage-free and pressure-free.
- b) Securely prevent restarting during all work.



⚠ WARNING

Failure of load-carrying parts due to overload!

Danger of injury from flying parts.

Danger of injury from spurting fluids.

- a) Depressurise the device and all connection lines before doing any work.
- b) Securely prevent the restoration of pressure while working on the device.



⚠ CAUTION

Hot surfaces

Burns of the skin on contact.

- a) At temperatures $\geq 48^{\circ}\text{C}$ the product must be allowed to cool down first.

9.2 Maintenance work



TIP

Checking and documentation of the operating data

Regular checking and documentation of all operating data helps to detect faults at an early stage.

- Perform maintenance according to specification.
- Replace defective and worn components.
- If required, request spare parts lists and assembly drawings from the manufacturer.
- Document the type and scope of the maintenance work along with the operating data.
- Compare the operating data with the values of the first commissioning. Determine the cause in case of major non-compliances (> 10 %).
- Dispose of packing material and used parts in accordance with the local stipulations.



NOTICE

Protective equipment and notices

After maintenance and/or repair, reattach all protective devices and notices removed in the process to their original position.

9.3 Maintenance instructions

The following information provides recommendations for maintenance work and maintenance intervals for the product in use.

Depending on the actual loads occurring during operation, the type, scope and interval of the maintenance work may deviate from the recommendations. A mandatory maintenance plan must be drawn up by the installer/operating company.



TIP

In the course of preventive maintenance, it is advisable to replace wearing parts before the wear limit is reached.

With the appropriate expertise and sufficient equipment, the repair can also be carried out by the installer/operating company.

If necessary, request spare parts lists and assembly drawings from the manufacturer. Please consult the manufacturer for this purpose.



NOTICE

Warranty

Any warranty will be void if not executed properly.

9.4 Maintenance table

Maintenance table

		Firstly:after max. 24 h	Daily	3000 Operating hours	6000 Operating hours	As required	Additional information
9.4.1	Inspection: Discharge flow	2					
9.4.2	Inspection: Operating pressure	2					
9.4.3	Inspection: Media temperature	2					
9.4.5	Inspection: Add-on valve function (if existing)	2					
9.4.6	Inspection: Check the potential compensation (if existing)	2					
9.4.7	Inspection: Condition of operating fluid	2					
9.4.8	Audiometric monitoring: Unusual noise		1				
9.4.9	Visual inspection: Leakages		1				
9.4.10	Visual inspection: Filling level of liquid seal (if existing)		2				
9.4.1	Inspection: Discharge flow			2			
9.4.2	Inspection: Operating pressure			2			
9.4.3	Inspection: Media temperature			2			
9.4.4	Inspection: Device temperature			2			
9.4.5	Inspection: Add-on valve function (if existing)			2			
9.4.6	Inspection: Check the potential compensation (if existing)			2			
9.4.7	Inspection: Condition of operating fluid			2			
9.4.11	Visual inspection: Condition gears				3		
9.4.12	Visual inspection: Condition of housing parts				3		
9.4.13	Visual inspection: Condition of plain bearings				3		
9.4.14	Visual inspection: Condition of shaft seal				3		
9.4.15	Replacing: Outboard bearings					3	
9.4.17	Replacing: Shaft seal					3	
9.4.18	Replacing: Other seals					3	

1 - 0,1 h; 2 - 0,2 h; 3 - 0,75 h

9.4.1 Inspection: Discharge flow

The discharge flow is measured via the flow rate volume counters.

The values are displayed by the built-in controller in the electrical control system.

- If there is no discharge flow, check the individual components of the product.
- Comply with the product-specific data sheets/operating instructions.

9.4.2 Inspection: Operating pressure

The operating pressure is indicated by the pressure gauges

- If there is no operating pressure, check the individual components of the product
- Comply with the product-specific data sheets/operating instructions.

9.4.3 Inspection: Media temperature

The media temperature is measured through the temperature sensor.

The values are displayed by the built-in controller in the electrical control system.

- If the media temperature is too high or too low, check the product components.
- Comply with the product-specific data sheets/operating instructions.

9.4.4 Inspection: Device temperature

Measure the surface temperature in the area of the bearings.

9.4.5 Inspection: Add-on valve function (if existing)

Pressure relief valves must be actuated at regular intervals. This is the only way to ensure proper functioning.

9.4.6 Inspection: Check the potential compensation (if existing)

Check potential equalization for tight fit and function.

9.4.7 Inspection: Condition of operating fluid

Pay attention to colour (dark colouring), odour and milky turbidity.

- Replace operating fluid if necessary.

9.4.8 Audiometric monitoring: Unusual noise

In this case, attention must be paid to increased noise or uneven operation (pump unit).

- In case of unusual noises, check the individual components of the product, line attachments and the operating media for foam formation.
- Comply with the product-specific data sheets/operating instructions.

9.4.9 Visual inspection: Leakages

Care must be taken here to ensure that there is no leakage from the connections.

- In the event of leaks in the connections, the glands must be tightened and, if necessary, the seals replaced.

9.4.10 Visual inspection: Filling level of liquid seal (if existing)

Checking the confining fluid filling level is mandatory for safe pump operation. Top up the confining fluid as required.

If there is no automatic monitoring, the filling level must be checked at least before each shift begins.

If the filling level drops unusually fast within a short period of time, the outer but also the inner shaft seal could be leaking.

If the filling level should rise, the inner shaft seal may probably be leaking and the confining fluid is begin mixed with the pressurised medium.

- Stop plant operation immediately in both cases.

9.4.11 Visual inspection: Condition gears

Like shaft gear are wear items. In the event of excessive wear, the parts or the pump must be replaced.

Important control points are the mating surfaces of the shaft sealing ring and bearing bushes, the end faces of the shaft and pin wheels and the tooth flanks.

9.4.12 Visual inspection: Condition of housing parts

Like shaft gear are wear items. In the event of excessive wear, the parts or the pump must be replaced.

Important control points are the mating surfaces of the shaft sealing ring and bearing bushes, the end faces of the shaft and pin wheels and the tooth flanks.

9.4.13 Visual inspection: Condition of plain bearings

Like plain bearings are wear items. In the event of excessive wear, the parts or the pump must be replaced..

The wear limit of multi-layer plain bearings is reached when the bronze layer of the bearings is exposed to 50-70%.

The drive shaft and driven shaft are supported on the suction side under load in the bearings, so that the wear can be seen there first.

9.4.14 Visual inspection: Condition of shaft seal

Check on increased and impermissible temperature rises

- Small amounts of leakage, however, are indispensable for function.
- If there are excessive amounts of leakage, stop pump operation immediately.
Replace: Shaft seal.

9.4.15 Replacing: Outboard bearings

With corresponding expertise and sufficient equipment, the replacement can be carried out by the equipment builder/operator.

If required, request spare parts lists and assembly drawings from the manufacturer.

Use spare parts approved by the manufacturer only.

9.4.16 Replacing: Plain bearings (only by manufacturer)

The replacement is carried out only by the manufacturer.

Consult the manufacturer

9.4.17 Replacing: Shaft seal

With corresponding expertise and sufficient equipment, the replacement can be carried out by the equipment builder/operator.

If required, request spare parts lists and assembly drawings from the manufacturer.

Use spare parts approved by the manufacturer only.

9.4.18 Replacing: Other seals

With corresponding expertise and sufficient equipment, the replacement can be carried out by the equipment builder/operator.

If required, request spare parts lists and assembly drawings from the manufacturer.

Use spare parts approved by the manufacturer only.

10 Repairs

10.1 Safety instructions for repair



DANGER

Hazardous fluids

Danger to life when handling hazardous fluids.

- a) Comply with the safety data sheets and regulations on handling the hazardous fluids.
- b) Collect and dispose of hazardous fluids so that no hazard is created for persons or the environment.



DANGER

Rotating parts!

Danger of death due to body parts, hair or clothing getting trapped or entangled.

- a) Before all work, ensure that existing drives are voltage-free and pressure-free.
- b) Securely prevent restarting during all work.



WARNING

Failure of pressure bearing parts due to overload

Risk of injury from flying parts.

Risk of injury due to splashing fluids.

- a) Depressurize the system before all work.
- b) Securely prevent the pressure from being restored during work.



CAUTION

Hot surfaces

Burns of the skin on contact.

- a) At temperatures $\geq 48^{\circ}\text{C}$ the product must be allowed to cool down first.

10.2 General

The repairs covers:

1. Troubleshooting
Determination of damage, pinpointing and localisation of the damage cause.
2. Elimination of damage
Elimination of the primary causes and replacement or repair of defective components.
The repair is generally made by the manufacturer.

Repairs by manufacturer

Before returning the device, fill in the return notification form. The form can be filled in online and is available as a pdf file download.



NOTICE

Device contains hazardous material

If the device was operated with dangerous liquids, it must be cleaned before the return. If this should not be possible, the safety data sheet of the hazardous material is to be provided beforehand.

Repair by equipment builder/operator

If corresponding expertise and sufficient equipment is available, the equipment builder/operator can also make the repairs. Please consult the manufacturer about this.

- a) If required, request spare parts lists and assembly drawings from the manufacturer.
- b) Use spare parts approved by the manufacturer only
- c) Dispose of packing material and used parts in accordance with the local stipulations.



NOTICE

Warranty

Any warranty will be void if not executed properly.



NOTICE

Protective equipment and notices

After maintenance and/or repair, reattach all protective devices and notices removed in the process to their original position.

10.3 Detecting and eliminating failures

Fault	Potential causes	Possible measures
Increased noise		
Pump cavitation	Excessive negative pressure (not complete filling of the pump)	Check suction line design Use noise-optimised pump
	Suction line clogged	Clean the suction line
	Suction filter plugged or too small	Clean suction filter or use a larger filter Replace filter element
	Suction bascet plugged or too small	Clean intake strainer or dimension larger
	Fluid temperature too low	Adjust the temperature of medium
Foaming or air in media	Pump does not suck	Check the oil level in the tank
		Check suction line
		Check the shaft seal
	Shaft seal defective	Replace seals
	Suction connection leaking	Tighten or replace the screw connections
		Replace seals
	System not vented	Vent the system
Return line ends above the fluid level	Extend return line	
Heavy foaming in the system, e.g. in gears	Use noise-optimised pump	
Mechanical vibrations	Incorrectly aligned and/or loose coupling	Correct the alignment of the coupling and secure the coupling halves
	Incorrectly and/or insufficient line fastening	Fixate lines with suitable fastening material (e.g. pipe clamps)
	Wobbling pressure relief valve	Increase valve opening pressure
	Not a noise-reducing setup	Use dampers
Pump does not suck		
	Dry run	Fill pump and the suction line with medium
	Minimum filling level in the reservoir tank undercut	Refill media
	Wrong direction of rotation	Correct the direction of rotation
	Throttled/closed shut-off element in the suction line	Open the shut-off element
	Suction line clogged	Clean the suction line
	The air in the suction line cannot be compressed in the pressure line	Reduce the start-up pressure Vent the pressure line

		Increase volume of the pressure line
	Speed of the pump is too low	Check the pump design
		During frequency inverter operation: Check the operation/line frequency
	Geodetic suction head too high	Check installation location
		Provide pre-filling pump
Insufficient pressure		
Insufficient pumping flow rate		
	Excessive negative pressure (not complete filling of the pump)	Check suction line design
	Too high media viscosity	Provide pre-filling pump
	Speed of the pump is too low	Check the pump design
		During frequency inverter operation: Check the operation/line frequency
	Throttled/closed shut-off element in the suction line	Open the shut-off element
	Suction line clogged	Clean the suction line
	Suction filter plugged or too small	Clean suction filter or use a larger filter
		Replace filter element
	Suction basket plugged or too small	Clean intake strainer or dimension larger
	No response of a pressure relief valve	Increase valve opening pressure
	Pump does not suck	Check the oil level in the tank
		Check suction line
		Check the shaft seal
	Wear	Replace the device
Excessive operating temperature		
	Cooling and heat dissipation insufficient	Increase the cooling capacity
	Not sufficient oil in the system	Check the container layout
	Excess fluid is being delivered into the supply tank via pressure relief valve under load	Check the pump design

Impermissible pump heating		
	No response of a pressure relief valve	Increase valve opening pressure
	Pressure too high in association with a media viscosity that is too low	Check the system design
	Speed too fast in connection with media viscosity that is too high	Check the system design
	Gland lid overtightened (for gland seal)	Unscrew gland lid and readjust leakage
	Suction pressure too high	Reduce the pressure
	Wear	Replace the device
Leakage		
Seal failure	Lack of maintenance	Comply with maintenance intervals Replace seals
	Mechanical damage	Replace seals
	Thermal overload	Check operating data Replace seals
	Pressure too high	Check operating data Replace seals
	Gas content in media too high	Check operating data Replace seals
	Corrosion/chemical degradation	Check material compatibility Replace seals
	Wrong direction of rotation	Correct the direction of rotation Replace seals
	Contaminated medium	Provide filtration Replace seals
	Gland lid not sufficiently tightened (for gland seal)	Retighten gland lid
	Loose screw connection	Tighten or replace the screw connections
Motor protection switch tripped		
	Driving power too low	Check the drive design
	Motor incorrectly connected	Check motor connection
	Phase failure	Check feed/supply
	Current consumption too high	Check operating data
		Check direction of rotation
	Motor circuit breaker incorrectly designed	Check operating data
Consult the manufacturer in the event of unidentifiable faults		