

# KRACHT

D.0044500002

## Operating instructions (Translation)

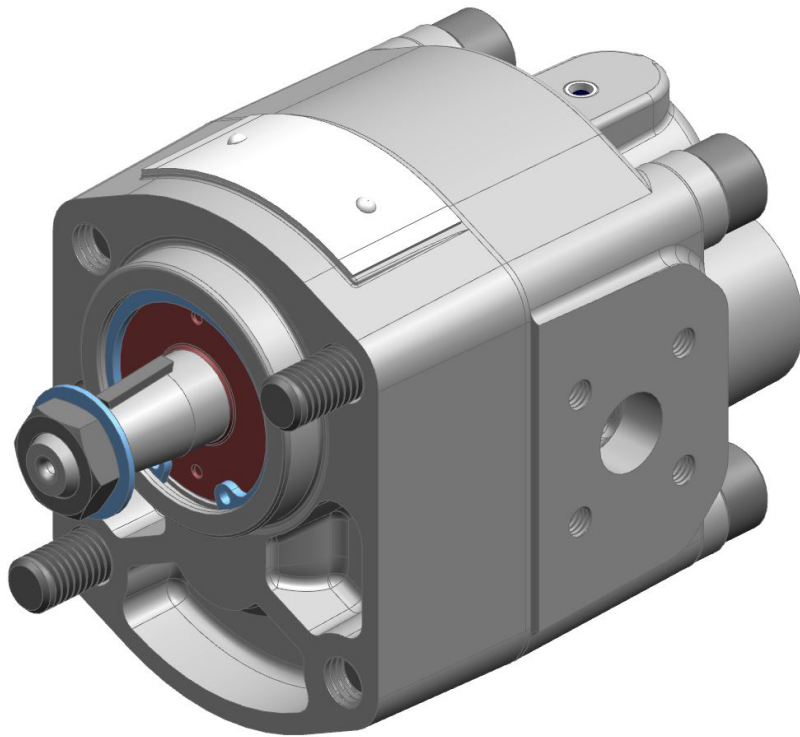

High pressure gear pump KP 1 series 2  
English

# Table of content

<b>1 General .....</b>	<b>4</b>
1.1 About the documentation .....	4
1.2 Manufacturer address .....	4
1.3 Other applicable documents .....	4
1.4 Symbols.....	5
<b>2 Safety.....</b>	<b>6</b>
2.1 Intended use.....	6
2.2 Personal qualification .....	6
2.3 Basic safety instructions .....	7
2.4 Fundamental hazards .....	8
<b>3 Device description.....</b>	<b>10</b>
3.1 Functional principle.....	10
3.2 Variants .....	11
3.3 Type key.....	12
3.4 Direction of rotation and discharge .....	13
3.5 Types of seals .....	13
3.6 Special numbers .....	14
3.7 Shaft ends .....	14
<b>4 Technical data.....</b>	<b>15</b>
4.1 General.....	15
4.1.1 Flame resistant fluids compliant with VDMA 24317 .....	16
4.2 Nominal sizes.....	17
4.3 Assignment of viscosity - speed.....	17
4.4 Allowable pressures .....	18
4.5 Permissible temperature range .....	18
4.6 Material data.....	18
4.7 Weight.....	19
4.8 Dimensions.....	19
<b>5 Transport and storage .....</b>	<b>20</b>
5.1 General.....	20
5.2 Transport.....	20
5.3 Storage.....	20
5.4 Storage conditions .....	21
<b>6 Installation .....</b>	<b>22</b>
6.1 Safety instructions for installation.....	22
6.2 Noise reduction .....	23
6.3 Mechanical installation .....	24

6.3.1	Preparation.....	24
6.3.2	Gear pump with free shaft end .....	24
6.4	Connection lines.....	26
6.4.1	General.....	26
6.4.2	Suction line.....	26
6.4.3	Pressure pipe.....	28
6.4.4	Connection line installation.....	28
6.5	Change of the direction of rotation.....	28
<b>7</b>	<b>Commissioning.....</b>	<b>29</b>
7.1	Safety instructions for start-up.....	29
7.2	Preparation.....	30
7.3	Additional commissioning.....	30
<b>8</b>	<b>Removal.....</b>	<b>31</b>
8.1	Safety instructions for disassembly.....	31
8.2	Dismantling .....	32
<b>9</b>	<b>Maintenance .....</b>	<b>33</b>
9.1	Safety instructions for maintenance.....	33
9.2	Maintenance work.....	34
9.3	Maintenance instructions.....	34
9.4	Maintenance table.....	35
9.4.1	Maintenance table.....	35
9.4.2	Check the operating pressure.....	36
9.4.3	Check the media temperature.....	36
9.4.4	Check the device temperature .....	36
9.4.5	Check the function of the add-on valve .....	36
9.4.6	Check the equipotential bonding .....	36
9.4.7	Check the condition of the operating fluid .....	36
9.4.8	Noise test unusual noises.....	36
9.4.9	Cleaning .....	36
9.4.10	Visual inspection of leakage.....	36
9.4.11	Visual check of the gearbox condition.....	37
9.4.12	Visual check of the condition of housing parts .....	37
9.4.13	Visual check of the condition of the plain bearings .....	37
9.4.14	Visual check of the condition shaft seal .....	37
9.4.15	Visual check of the condition of the outboard bearing .....	37
9.4.16	Replacing the outboard bearing .....	37
9.4.17	Replacing the plain bearings.....	37
9.4.18	Replacing the shaft seal .....	38
9.4.19	Replacing other seals.....	38
<b>10</b>	<b>Repair .....</b>	<b>39</b>
10.1	Safety instructions for repairs .....	39
10.2	General.....	40
10.3	Fault table .....	41

# 1 General

## 1.1 About the documentation

These operating instructions describe the installation, operation and maintenance of the following product:

### **High pressure gear pump KP 1 series 2**

These operating instructions are an integral part of the product and must be kept in the immediate vicinity of the

product and accessible to the personnel at all time.

Different versions of the product are produced. Which version is concerned is stated on the device's type plate.

If you have any questions about this operating manual, please contact the manufacturer.

## 1.2 Manufacturer address

KRACHT GmbH  
Gewerbestraße 20  
D-58791 Werdohl  
Tel: +49 2392 935-0  
Fax: +49 2392 935-209  
Email: [info@kracht.eu](mailto:info@kracht.eu)  
Web: [www.kracht.eu](http://www.kracht.eu)

## 1.3 Other applicable documents

In addition to these instructions, also comply with the relevant instructions of plants or plant parts available or planned on site.

## 1.4 Symbols



### **DANGER**

Identification of an immediate hazard, which can lead to death or severe bodily injury if not avoided.



### **WARNING**

Identification of a potential medium risk hazard, which can lead to death or severe bodily injury if not avoided.



### **CAUTION**

Identification of a possible low-risk hazard that can result in minor or moderate physical injury if not avoided.

### **ATTENTION**

Identification of notes to prevent property damage.



### **NOTICE**

Identification of basic safety instructions. Non-compliance can lead to hazards for people and the product



### **TIP**

Identification of special user tips and other particularly useful or important information

## 2 Safety

### 2.1 Intended use

1. The product has been designed for operation with fluids.  
Dry operation is not permitted.
2. The product may only be operated when completely filled.
3. The fluid must be compatible with the materials used in the product. Chemical expertise is required for that. Be careful with ethylene oxide or other catalytically or exothermically reacting or self-decomposing substances. Please consult the manufacturer in cases of doubt.
4. The product may only be used in normal industrial atmospheres. If there are any aggressive substances in the air, always consult the manufacturer.
5. The product may only be operated in compliance with these operating instructions and the applicable documents.  
Deviating operating conditions require the express approval of the manufacturer.
6. Use of the product for purposes other than those for which it is intended invalidates any warranty.

### 2.2 Personal qualification

The personnel charged with the assembly, operation and maintenance of the product must have the necessary qualifications.

This can be achieved through training or appropriate instruction.

The personnel must be familiar with the contents of these operating instructions.



#### NOTICE

Read the operating instructions in full before using the product.

## 2.3 Basic safety instructions



### NOTICE

#### **Basic safety instructions**

Non-compliance can lead to hazards for people and the unit.

- a) Follow existing regulations for accident prevention and safety at work as well as the internal regulations of the operating company.
- b) Ensure the greatest possible cleanliness.
- c) Wear suitable personal protective equipment.
- d) Do not remove type plates or other information or make them illegible or unrecognisable.
- e) Do not make any technical modifications.
- f) Comply with maintenance intervals.
- g) Only use spare parts approved by the manufacturer.

## 2.4 Fundamental hazards



### **DANGER**

#### **Hazardous fluids**

Danger to life when handling hazardous fluids

- a) Comply with the safety data sheets and regulations on handling the hazardous fluids.
- b) Collect and dispose of hazardous fluids so that no hazard is created for persons or the environment.



### **DANGER**

#### **Hazardous fluids**

Danger to life when handling hazardous fluids.

- a) Defective components and connection lines must be replaced or fixed without delay.
- b) Use only components and connection lines approved for the expected pressure range.



### **DANGER**

#### **Rotating parts**

Risk to life due to entanglement or winding of parts of the body, hair or clothing items.

- a) Before carrying out any work, disconnect any drives and actuators from the power supply or depressurise them.
- b) Safely prevent restarting during the work.



### **DANGER**

#### **Rotating parts**

Risk to life due to entanglement or winding of parts of the body, hair or clothing items.

- a) Take measures to prevent accidental touching of rotating parts.



### **WARNING**

#### **Rotating parts**

Risk of injury caused by ejected parts

- a) Enclose rotating parts so that in the event of fracture or malfunction, there is no risk caused by ejected parts.



**⚠ WARNING****Failure of pressure bearing parts due to overload**

Risk of injury from flying parts.

Risk of injury due to splashing fluids.

- a) Before carrying out any work, depressurise the product and all connection pipes.
- b) Securely prevent the pressure from being restored during work.

**⚠ WARNING****Failure of pressure bearing parts due to overload**

Risk of injury from flying parts.

Risk of injury due to splashing fluids.

- a) Use only connections and lines approved for the expected pressure range.
- b) Securely prevent the permissible pressures from being exceeded, e.g. by using pressure relief valves or bursting discs.
- c) Pipelines must be designed in such a way that no tension e.g. caused by changes in length due to fluctuations in temperature can be transferred to the product.

**⚠ WARNING****Failure of pressure bearing parts due to overload**

Risk of injury caused by flying parts.

Risk of injury caused by splashing fluids.

- a) Do not operate the product with shut-off devices closed.
- b) Do not operate the production in the wrong rotational direction.

## 3 Device description

### 3.1 Functional principle

The pumps of this series are external gear pumps, which operate according to the displacement principle.

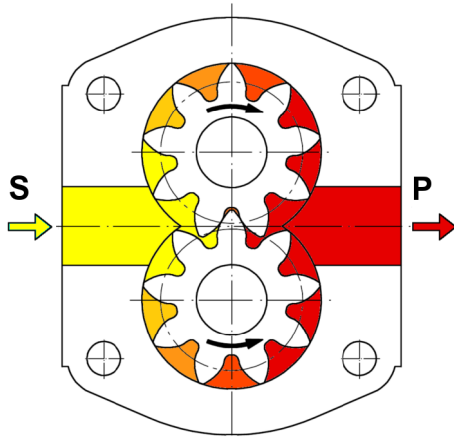

S Suction connection  
P Pressure connection

During rotation, two interlocking gears cause a volume increase by opening the tooth spaces on the suction side (S), so that the medium can flow in and at the same time, on the discharge side (pressure side, P), a corresponding volume is displaced by the meshing of the teeth in the filled tooth gaps. Fluid transport takes place through entrainment in the tooth spaces along the wall of the wheel chamber.

With each gear rotation, the so-called geometric displacement volume  $V_g$  is displaced.

A value that is named the rated volume  $V_{gn}$  in technical documents to specify the pump size.

The displacement process described takes place initially without a noticeable pressure build-up. Only after external loads are applied, e.g. by head, flow resistances, pipe elements, etc., does the required working pressure set in to overcome these resistances.

The pressure applied to the shaft seal equals the pressure at the suction connection of the product. The permissible pressure is determined by the type of seal.

Due to its design and the materials employed, the device is suitable for use under the harshest operating conditions. The main components (see "Basic design") are the housing and flange cover. They are highly loadable, making them resistant to pressure peaks and continuous vibrations. Large-surface dimensioned, bronze plain bearings on steel backs in the housing and flanged cover support the micro-finish ground bearing journals of the gear, which consists of a drive shaft and pinion wheel. To realise optimum running properties, the tooth flanks of the gear are ground.

The function of the active axial-tolerance compensation, indispensable for high-pressure pumps, is implemented by the sliding plates located beside the gears. They have hydraulically-loaded pressure-fields, through which a compensation of the axial tolerance allowance is guaranteed at every operating pressure. The pressure plates are designed so that clearance compensation is independent of viscosity. That ensures a high level of volumetric and mechanical efficiency at every operating point.

## 3.2 Variants

### Gear pump

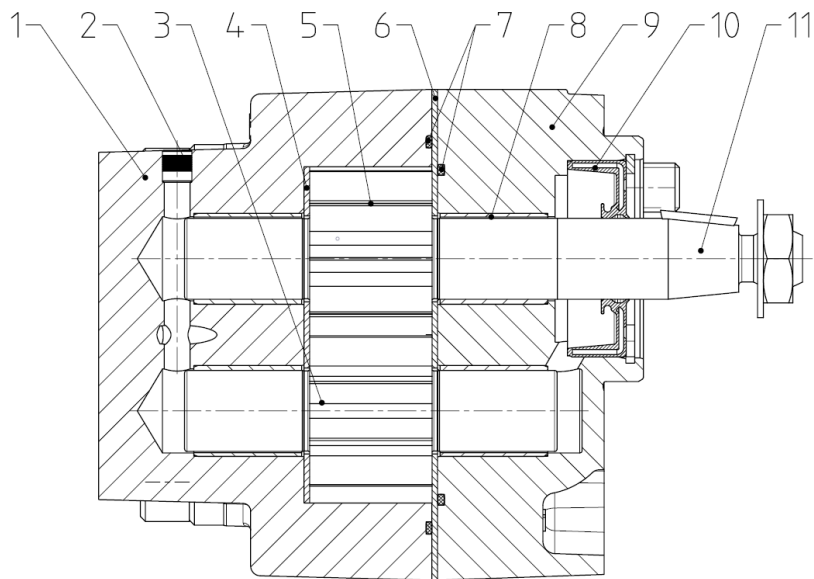

- |    |                    |    |                      |
|----|--------------------|----|----------------------|
| 1  | Housing            | 2  | Expander plugs       |
| 3  | Driven shaft       | 4  | Sliding collar plate |
| 5  | Driving shaft      | 6  | Pressure plate       |
| 7  | O-ring             | 8  | Plain bearings       |
| 9  | Flange cover       | 10 | Shaft seal           |
| 11 | End of drive shaft |    |                      |

### 3.3 Type key

Ordering example																				
KP	1/8	1	N	1	0	F	2	K	0	0	0	1	A	A	E	0	G	Q	W	/...
1.	2.	3.	4.	5.	6.	7.	8.	9.	10.	11.	12.	13.	14.	15.	16.	17.	18.	19.	20.	21.

Explanation of type key	
<b>1. Product name</b>	
<b>2. Nominal</b>	
V <sub>gn</sub>	Size 1: 3; 4; 5.5; 8; 11; 16; 20
<b>3. Housing material</b>	
1	EN-GJL-300
4	EN-GJS-400-18-LT
2	EN-GJS-400-15
6	EN-GJL-250
<b>4. Seal material</b>	
F	FKM
N	NBR
<b>5. Direction of rotation</b>	
1	Clockwise
2	Counterclockwise
<b>6. Outbord bearing</b>	
0	Without
L	light version
<b>7. Flange type</b>	
F	Square 2-hole flange LA= 60/60 Z-Ø= 50
G	Rectangular 4-hole flange LA= 72/100 Z-Ø= 80
LA= Hole distance; Z-Ø = Centering diameter	
<b>8. Flange cover material</b>	
2	EN-GJS-400-15
<b>9. Shaft end</b>	
K	Cone 1:5 Ø17
X	Gear shaft profile B17x14 DIN 5482
L	Cone 1:5 Ø16.5
<b>10. Type of end cover</b>	
0	Without
<b>11. Cover material</b>	
0	Without
<b>12. 2nd shaft end</b>	
0	Without
<b>13. Axial clearance compensation</b>	
1	Yes
0	Without
<b>14. Suction side connection</b>	
<b>Nominal</b>	
A	Ø15/LK40
	3; 4; 5.5
A	Ø20/LK40
	8; 11; 16; 20
B	G 3/4
<b>15. Pressure side connection</b>	
A	Ø15/LK35
B	G 3/4

Explanation of type key	
<b>16. Gear material</b>	
<b>E</b>	16MnCrS5 - 1.7139
<b>17. Gear coating</b>	
<b>0</b>	Without
<b>18. Type of bearing</b>	
<b>G</b>	Plain bearings
<b>19. Material bearing</b>	
<b>D</b>	Multi layer friction bearings (contains lead) (DU)
<b>Q</b>	Multi layer friction bearings (contains lead) (P23)
<b>20. Seal type</b>	
<b>W</b>	Rotary shaft seal
<b>21. Special number</b>	
Special numbers [▶ 14]	

### 3.4 Direction of rotation and discharge

The direction of rotation is indicated by the curved arrow, when looking towards the end of the drive shaft. The pump connections are below the drive shaft.

The flow direction is indicated by the straight arrow.

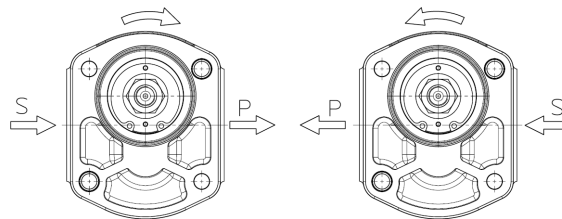

- S = Suction connection
- P = Pressure connection

### 3.5 Types of seals

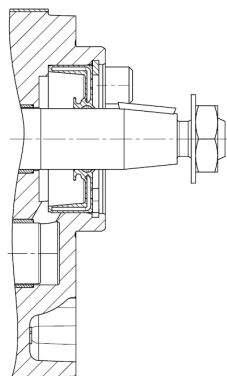

Rotary shaft seal

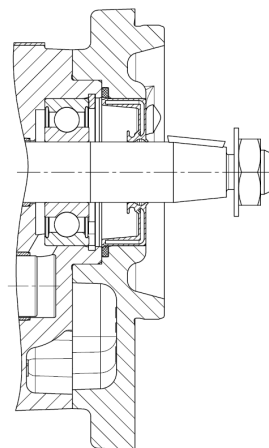

Rotary shaft seal with roller bearings

## 3.6 Special numbers

Special number	Description
250	Flange cover with o-ring notch in the centring
446	Without roller bearing and circlip, with attachment flange

## 3.7 Shaft ends

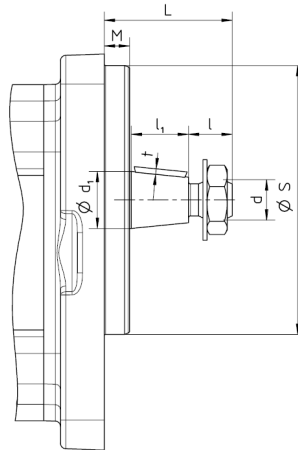

Flange cover	Outboard flange / Outboard bearing	Shaft end	L	S	M	Cone	d	d <sub>1</sub>	l	l <sub>1</sub>	t
F	0	K	40.5	50	8	1:5	M12x1,5	16.5	13	14.5	1.5
G	L	L	38	80	8						
G	0	K									
F	U	L	35	-	-						

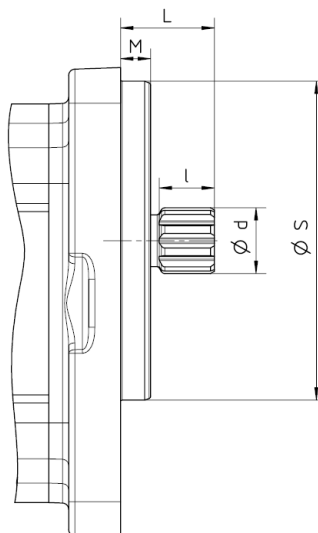

Flange cover	Outboard flange / Outboard bearing	Shaft end	L	S	M	Profile	DIN	Number of teeth	d <sub>h11</sub>	l
F	0	X	26	50	8	B17x14	5482	9	16.5	14

## 4 Technical data

### 4.1 General

General information		
<b>Mounting position</b>		Any <sup>(1)</sup>
<b>External loads on shaft end</b>	<b>F<sub>axial</sub></b>	Axial forces are not permissible
	<b>F<sub>radial</sub></b>	Axial and radial forces are only permissible in combination with an outboard bearing <b>Nominal sizes [ ▶ 17 ]</b>
<b>Speed</b>	<b>n</b>	<b>Nominal sizes [ ▶ 17 ]</b>
<b>Operating pressure</b>	<b>p<sub>e</sub></b>	<b>Allowable pressures [ ▶ 18 ]</b>
	<b>p<sub>b</sub></b>	
<b>Viscosity</b>	<b>v<sub>min</sub></b>	1.2 mm <sup>2</sup> /s
	<b>v<sub>max</sub></b>	600 mm <sup>2</sup> /s
<b>Fluid temperature</b>	<b>ϑ<sub>m</sub></b>	<b>Permissible temperature range [ ▶ 18 ]</b>
<b>Ambient temperature</b>	<b>ϑ<sub>u</sub></b>	
<b>Materials</b>		<b>Material data [ ▶ 18 ]</b>
<b>Ölreinheit</b>		NAS 1638 Class 10
		ISO 4406: 1999 Code 21/19/16
<b>Permissible media</b>		Mineral oil according to DIN 51524/25
		Motor oil according to DIN 51511
		Bio-oils of the "HEES" group can be used up to 70 °C and at maximum pressure reduced by about 20 %
<sup>(1)</sup> wasserhaltigen Flüssigkeiten <b>Flame resistant fluids compliant with VDMA 24317 [ ▶ 16 ]</b>		



#### TIP

A reduced shaft seal life is possible in the vertical installation position (shaft end at the top).

### 4.1.1 Flame resistant fluids compliant with VDMA 24317

Fluids	Maximum pressure	Speed		Temperature	Seal
	$p_{e \max.}$ [bar]	$n_{\min.}$ [rpm]	$n_{\max.}$ [rpm]	$\vartheta$ [°C]	
<b>HFA</b>	40	1400	1800	5...55	NBR
<b>HFB</b>	80	s.data sheet		5...60	
<b>HFC</b>	120			-20...60	
<b>HFDR</b>	140			-20...110	FKM

**HFA** Moisture content > 80% (Oil in water emulsion)  
**HFB** Moisture content > 40% (Oil in water emulsion)  
**HFC** Moisture content > 35% (wässrige Polymer-Lösungen)  
**HFDR** Moisture content = 0% (Aqueous polymer solutions)



#### NOTICE

Do not use water glycol coolants (e.g. glythermin from BASF)!



#### TIP

With HFA, HFB and HFC (all aqueous fluids), take note that all components that come into contact with air (parting line between the medium and the air in the tank or air bubbles in the components) will corrode. For that reason, tanks require a special coating and it is mandatory that the pumps be installed under the tank level outside and inside. Never allow the pumps to run dry. When installing in the tank, the pumps must always be completely immersed in the medium.

#### ⚠ ATTENTION

In case of varying volumes, always pay attention to and monitor the lowest liquid level!



## 4.2 Nominal sizes

Nominal $V_{gn}$	Geom. displacement $V_g$ [cm <sup>3</sup> /rev.]	Speed $n_{max}$ [rpm]	Minimum speeds					Perm. radial force $F_{radial}$ [N]  (n = 1500 rpm)	Mass inertia $\times 10^{-6}$  J [kg m <sup>2</sup> ]	
			at p= ... bar							
			100	120	150	180	200			
<b>3</b>	3.2	4000	700	800	1000	1200	1200	340	24.8	
<b>4</b>	4.7		600		900	100	1100		31.1	
<b>5.5</b>	5.7		500	700					1000	35.7
<b>8</b>	8.3									61.2
<b>11</b>	11.3	3500	600	800	900	-	85.5			
<b>16</b>	16.6	3000			800		104.2			
<b>20</b>	20.4	2500			-					

## 4.3 Assignment of viscosity - speed

Nominal $V_{gn}$	Kinematic viscosity $\nu$ [mm <sup>2</sup> /s]	Pressure p [bar]	Speed n [rpm]	Mechanical efficiency				
				$\eta_{vol}$ [%]	$\eta_{hm}$ [%]			
<b>4</b>	34	220	1450	75	75			
	4	80						
	1.2	40						
<b>11</b>	34	180		1450	90	90		
	4	80						
	1.2	40						
<b>20</b>	34	140			89		85	82
	4	80						
	1.2	40						

## 4.4 Allowable pressures

## 4.5 Permissible temperature range

Sealing material	Fluid temperature $\vartheta_m$	
	$\vartheta_{m \min}$ [°C]	$\vartheta_{m \max}$ [°C]
FKM	-15	110 (P23 - Plain bearings)
		150 (DU - Plain bearings)
NBR	-20	90

Sealing material	Ambient temperature $\vartheta_u$	
	$\vartheta_{u \min}$ [°C]	$\vartheta_{u \max}$ [°C]
FKM	-15	60
NBR	-20	



### NOTICE

Note media-specific properties.

## 4.6 Material data

Materials					
Shaft seal	O-ring	Housing	Flange cover	Gears	Bearing
NBR		EN-GJL-300			
FKM		---	EN-GJS-400-15	Casehardened steel (16MnCrS5 - 1.7139)	Multi layer friction bearings (contains lead) DU, P23
		EN-GJL-250			
		---			
		EN-GJS-400-15			
		---			
		EN-GJS-400-18LT			

## 4.7 Weight

Nominal $V_{gn}$	Gear pump [kg]				
	Fixing type				
	F	F	F	G	F
	K-Shaft	X-Shaft	L-Shaft	K-Shaft	L-Shaft
			With attachment bearing		With attachment bearing / with mounting bracket
<b>3</b>	4.4	4.2	5.4	5.3	6.0
<b>4</b>					
<b>5.5</b>	4.2	4.0	5.2	5.1	5.8
<b>8</b>	4.3	4.1	5.3	5.2	5.9
<b>11</b>	4.4	4.2	5.4	5.3	6.0
<b>16</b>				5.2	
<b>20</b>	4.6	4.4	5.6	5.5	6.2

## 4.8 Dimensions

The dimensions of the product are given in the technical data sheets.

## 5 Transport and storage

### 5.1 General

- a) After receiving the delivery, check the product for transport damage.
- b) If transport damage is found, the manufacturer and the transport company must be notified immediately. The product must then be replaced or repaired.
- c) Dispose of packaging materials and used parts according to local regulations.

### 5.2 Transport



#### **⚠ WARNING**

##### **Falling or toppling loads**

Risk of injury during transport of large and heavy loads.

- a) Use only suitable means of transport and lifting gear with sufficient load-bearing capacity.
- b) Attach lifting gear only to suitable places on the load.
- c) Attach the lifting gear so that it cannot slip.
- d) Note the centre of gravity of the load.
- e) Avoid sudden, jerky movements, impacts and strong vibrations during transport.
- f) Do not step under overhead loads, do not work under overhead loads.



#### **NOTICE**

Eyebolts can be screwed into the thread of the flanged connections to transport the product.

### 5.3 Storage

The product's function is tested in the factory with mineral hydraulic oil. The connections are then closed. The remaining residual oil preserves the internal parts for up to 6 months.

Bright metallic external parts are also protected against corrosion by suitable preservation measures for up to 6 months.

During storage, ensure a dry, dust-free and low-vibration environment. The product must be protected from weather, moisture and large temperature fluctuations. Comply with the recommended storage conditions.

Below the permissible ambient temperature  $\vartheta_U$ , elastomer seals lose their elasticity and mechanical loading capacity, as the temperature is below the glass transition temperature. This process is reversible. Avoid the application of force on the product during storage below the permissible ambient temperature  $\vartheta_U$ .

Products with EPDM seals are not mineral oil resistant and their function is not tested. The internal parts are not preserved. If the product is not put into operation immediately, all surfaces exposed to corrosion must be protected by suitable preservation measures. The same applies to products that are not tested for other reasons.

In case of storage for a longer period (> 6 months), all surfaces exposed to corrosion must be retreated with suitable preservatives.

If high humidity or an aggressive atmosphere is to be expected, additional suitable corrosion prevention measures must be taken.



## NOTICE

Storage in corrosion protection bags (VCI) for maximum 6 months.

## ⚠ ATTENTION

### Corrosion/chemical attack

Improper storage can make the product unusable.

- a) Use suitable preservation measures to protect exposed surfaces.
- b) Comply with the recommended storage conditions.

## 5.4 Storage conditions



## TIP

### Recommended storage conditions

- a) Storage temperature: 5 °C – 25 °C
- b) Relative humidity: < 70 %
- c) Protect elastomer parts from light, particularly direct sunlight.
- d) Protect elastomer parts from oxygen and ozone.
- e) Note the maximum storage period of elastomer parts:
  - ⇒ 5 years: AU (polyurethane rubber)
  - ⇒ 7 years: NBR, HNBR, CR
  - ⇒ 10 years: EPM, EPDM, FEP/PFTE, FEPM, FKM, FFKM, VMQ, FVMQ

## 6 Installation

### 6.1 Safety instructions for installation



#### **⚠ DANGER**

##### **Hazardous fluids**

Danger to life when handling hazardous fluids

- a) Comply with the safety data sheets and regulations on handling the hazardous fluids.
- b) Collect and dispose of hazardous fluids so that no hazard is created for persons or the environment.



#### **⚠ DANGER**

##### **Rotating parts**

Risk to life due to entanglement or winding of parts of the body, hair or clothing items.

- a) Before carrying out any work, disconnect any drives and actuators from the power supply or depressurise them.
- b) Safely prevent restarting during the work.



#### **⚠ DANGER**

##### **Rotating parts**

Risk to life due to entanglement or winding of parts of the body, hair or clothing items.

- a) Take measures to prevent accidental touching of rotating parts.



#### **⚠ WARNING**

##### **Rotating parts**

Risk of injury caused by ejected parts

- a) Enclose rotating parts so that in the event of fracture or malfunction, there is no risk caused by ejected parts.



#### **⚠ WARNING**

##### **Exposed gears**

Gearwheels can trap and crush fingers and hands.

- a) Do not engage gearwheels.

**⚠ WARNING****Failure of pressure bearing parts due to overload**

Risk of injury from flying parts.

Risk of injury due to splashing fluids.

- a) Before carrying out any work, depressurise the product and all connection pipes.
- b) Securely prevent the pressure from being restored during work.

**⚠ WARNING****Failure of pressure bearing parts due to overload**

Risk of injury from flying parts.

Risk of injury due to splashing fluids.

- a) Use only connections and lines approved for the expected pressure range.
- b) Securely prevent the permissible pressures from being exceeded, e.g. by using pressure relief valves or bursting discs.
- c) Pipelines must be designed in such a way that no tension e.g. caused by changes in length due to fluctuations in temperature can be transferred to the product.

## 6.2 Noise reduction

**TIP****Measures to reduce noise**

- a) Use of suction and pressure hoses.
- b) Use of pump supports with high damping properties (plastic or grey cast iron)
- c) Use of damping rings and damping rails to isolate structure-borne sound.

## 6.3 Mechanical installation

### 6.3.1 Preparation

- 
- a) Check the product for transport damage and contamination.
  - b) Check the product for smooth and easy movement.
  - c) Remove any preservative present.
  - d) Clean all lines.
    - ⇒ Only use cleaning agents that are compatible with the materials used.
    - ⇒ Do not use cleaning wool.
  - e) Compare the environmental and ambient conditions at the place of use with the permissible conditions.
    - ⇒ Make sure that the foundation is sufficiently stable and level.
    - ⇒ Expose the product only to low vibrations, see IEC 60034-14.
    - ⇒ Ensure sufficient accessibility for maintenance and repair.
  - f) Position the product and secure it against slipping.
    - ⇒ Comply with the manufacturer's instructions.
    - ⇒ Do not use any sealing materials such as hemp, Teflon tape or putty.
  - g) Remove existing protective plugs.
- 

### 6.3.2 Gear pump with free shaft end

Suitable power transmission between the gear pump and drive is required for fault-free operation.

In a standard product, a flexible claw coupling is used for this.

- 
- a) Preassemble the coupling parts as described by the manufacturer.
  - b) Position the pump and drive relative to each other.
    - ⇒ Note the allowable installed position.
    - ⇒ Note the allowable direction of rotation.
  - c) Tighten the fastening screws to the specified torque.
- 



#### **⚠ DANGER**

##### **Rotating parts**

Risk to life due to entanglement or winding of parts of the body, hair or clothing items.

- a) Take measures to prevent accidental touching of rotating parts.
-





## ⚠ CAUTION

### Hot surfaces

Burns of the skin on contact.

- a) Wear protective gloves at temperatures  $\geq 48^{\circ}\text{C}$ .

Tightening torques [Nm]							
Thread size	M6	M8	M10	M12	M16	M20	M24
Counter-thread Aluminium	4.6	11	22	39	95	184	315
Counter-thread Cast iron / Steel	10	25	49	85	210	425	730

Screws/Nuts with min. strength class 8.8/8



## NOTICE

- a) Comply with the allowable displacement values of the coupling.
- b) Prevent stressing of the product.
- c) Make sure the fastening screws have sufficient depth of engagement.



## NOTICE

- a) In case of products without a shaft seal, make sure that the leaked oil from the shaft seal space is removed in a controlled way and does not get into the environment.
- b) Make sure that foreign objects cannot get into the product.
- c) If products have a fluid seal, install a tank for holding the seal fluid.
  - ⇒ Install the tank above the product.
  - ⇒ The connection on the device must face upwards.
  - ⇒ It must be possible to check the fluid level at any time.

## 6.4 Connection lines

### 6.4.1 General



#### **WARNING**

##### **Failure of pressure bearing parts due to overload**

Risk of injury from flying parts.

Risk of injury due to splashing fluids.

- a) Use only connections and lines approved for the expected pressure range.
- b) Securely prevent the permissible pressures from being exceeded, e.g. by using pressure relief valves or bursting discs.
- c) Pipelines must be designed in such a way that no tension e.g. caused by changes in length due to fluctuations in temperature can be transferred to the product.



#### **NOTICE**

##### **Additional connections**

- a) Provide measurement connections for pressure and temperature as near as possible on the device.
- b) If necessary, provide an option for filling and draining the device and line system.
- c) If necessary, provide an option for venting the device and line system.

### 6.4.2 Suction line

A suction line that is not optimally designed can lead to increased noise emissions, cavitation and even a reduction in the capacity (due to less filling of the pump).

When designing the lines, bear in mind the following points:

- Lay the suction line as short and straight as possible.
- Specify the nominal size of the suction line so that the operating pressure on the suction side is not less than the permissible operating pressure  $p_{e \text{ min}}$ .
- Avoid large suction heights.
- Avoid additional pressure loss through line resistances such as fittings, screwed connections, formed parts or suction filters/suction baskets. Ensure that all technically required suction filters/suction baskets are appropriately dimensioned.
- Pay attention to sufficient distance of the suction opening from the floor and walls of the media tank.
- Make sure that the suction opening is below the lowest fluid level in any operating situation.
- When using hoses, make sure that they have sufficient stability so that they do not become constricted by the suction effect.
- Note the recommended flow velocity in the suction line (max. 1.5 m/s).



## NOTICE

### Cavitation damage

Pressure below the permissible suction side pressure causes cavitation

- a) Design the suction line so that the pressure that sets in during operation is always higher on the suction side than the vapour pressure of the pumped medium. At the same time, make sure that the device is installed above sea level.
- b) If fluids contain water, install the device below the fluid level and limit the operating temperature to 50 °C and the speed to 1500 1/min.

### Prevention of suction problems

If there is a possibility of the suction line running dry while the pump is at a standstill, laying the suction line as a U-trap is a way of avoiding suction problems. This way, the pump will remain permanently filled after initial commissioning.

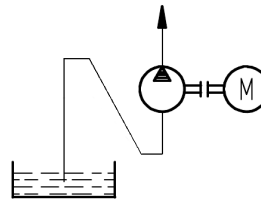

In case of longer suction lines that can run empty during the standstill, it is useful to insert a foot valve or a non-return valve. These must have been designed for use in suction lines and should offer as low a flow resistance as possible.

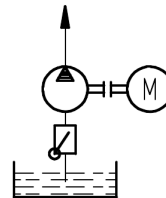

When operating a pump that has to pump via a non-return valve into a pressurized circuit (e.g. reserve pump in a lubricant circuit), intake difficulties can occur if the suction line is filled with air. In this case the pressure line must be vented directly upstream of the non-return valve. If a venting nozzle is not inserted, the volume of the pressure line between the pump and non-return valve must be at least 75% of the suction line volume.

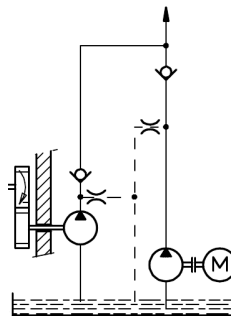

### 6.4.3 Pressure pipe

When designing the lines, bear in mind the following points:

- Choose the nominal size of the pressure line so that the maximum permissible pressures are not exceeded.
- If necessary, provide a venting nozzle to prevent suction problems.

### 6.4.4 Connection line installation

---

- a) Clean all lines.
    - ⇒ Do not use cleaning wool.
    - ⇒ Pickle and rinse welded pipes.
  - b) Remove existing protective plugs.
  - c) Install the lines.
    - ⇒ Comply with the manufacturer's instructions.
    - ⇒ Do not use any sealing materials such as hemp, Teflon tape or putty.
- 



#### TIP

Location of the device connections: Direction of rotation and discharge

---

## 6.5 Change of the direction of rotation

A change in the direction of rotation is not possible.

## 7 Commissioning

### 7.1 Safety instructions for start-up



#### **⚠ DANGER**

##### **Hazardous fluids**

Danger to life when handling hazardous fluids

- a) Comply with the safety data sheets and regulations on handling the hazardous fluids.
- b) Collect and dispose of hazardous fluids so that no hazard is created for persons or the environment.



#### **⚠ WARNING**

##### **Failure of pressure bearing parts due to overload**

Risk of injury caused by flying parts.

Risk of injury caused by splashing fluids.

- a) Do not operate the product with shut-off devices closed.
- b) Do not operate the production in the wrong rotational direction.



#### **⚠ CAUTION**

##### **Hot surfaces**

Burns of the skin on contact.

- a) Wear protective gloves at temperatures  $\geq 48^{\circ}\text{C}$ .

## 7.2 Preparation

---

- a) Before starting the system make sure that a sufficient quantity of the service fluid is extant to avoid dry running. This must be taken into account especially with large line volumes.
  - b) Check all fastening screws on the product.
  - c) Fill the pump and the suction line with medium.
- 

## 7.3 Additional commissioning

---

- a) Open existing shut-off elements in front of and behind the product.
  - b) Set pressure relief valves installed in the system to the lowest opening pressure.
  - c) Start the product without pressure load or with low pressure (jog mode).
    - ⇒ A flow should have developed after 30 s at the latest.
  - d) Run the product pressureless or at low pressure for a few minutes.
  - e) Vent the system at the highest possible point.
  - f) Gradually increase the pressure up to the required operating pressure.
  - g) Operate the system until the final operating condition is reached.
  - h) Check the operating data.
    - ⇒ **Maintenance table [▶ 35]**
  - i) Document the operating data of the initial commissioning for later comparison.
  - j) Check the level of the operating medium in the system.
  - k) Check the level of the seal fluid (if present).
  - l) Check the product for leaks.
  - m) Check all fittings for leaks and retighten if necessary.
- 



### TIP

In order to ensure a constant and reliable function of the product, an initial maintenance of the product is recommended after several hours warm-up time (max. 24 h). This allows faults to be detected at an early stage.

---

## 8 Removal

### 8.1 Safety instructions for disassembly



#### **⚠ DANGER**

##### **Hazardous fluids**

Danger to life when handling hazardous fluids

- a) Comply with the safety data sheets and regulations on handling the hazardous fluids.
- b) Collect and dispose of hazardous fluids so that no hazard is created for persons or the environment.



#### **⚠ DANGER**

##### **Rotating parts**

Risk to life due to entanglement or winding of parts of the body, hair or clothing items.

- a) Before carrying out any work, disconnect any drives and actuators from the power supply or depressurise them.
- b) Safely prevent restarting during the work.



#### **⚠ WARNING**

##### **Exposed gears**

Gearwheels can trap and crush fingers and hands.

- a) Do not engage gearwheels.



#### **⚠ WARNING**

##### **Failure of pressure bearing parts due to overload**

Risk of injury from flying parts.

Risk of injury due to splashing fluids.

- a) Before carrying out any work, depressurise the product and all connection pipes.
- b) Securely prevent the pressure from being restored during work.



#### **⚠ CAUTION**

##### **Hot surfaces**

Burns of the skin on contact.

- a) At temperatures  $\geq 48$  °C allow the product to cool first.

 **ATTENTION****Blocking of the product due to curing media**

Curing media can mechanically block the product and make it unusable.

- a) Clean the product immediately after operation with curing media.

## 8.2 Dismantling

- a) Depressurise and de-energise the system.
- b) Close existing shut-off elements in front of and behind the product.
- c) Open existing drain elements and undo connection lines. Collect and dispose of leaking media so that no hazard is created for persons or the environment.
- d) Dismantle the product.
- e) Clean the product.
- f) Seal the process connections and lines to prevent the ingress of dirt.

**NOTICE**

The concrete procedure for cleaning depends on the media being used.

- a) See the safety data sheet of the media in use.



## 9 Maintenance

### 9.1 Safety instructions for maintenance



#### **⚠ DANGER**

##### **Hazardous fluids**

Danger to life when handling hazardous fluids

- a) Comply with the safety data sheets and regulations on handling the hazardous fluids.
- b) Collect and dispose of hazardous fluids so that no hazard is created for persons or the environment.



#### **⚠ DANGER**

##### **Rotating parts**

Risk to life due to entanglement or winding of parts of the body, hair or clothing items.

- a) Before carrying out any work, disconnect any drives and actuators from the power supply or depressurise them.
- b) Safely prevent restarting during the work.



#### **⚠ WARNING**

##### **Failure of pressure bearing parts due to overload**

Risk of injury from flying parts.

Risk of injury due to splashing fluids.

- a) Before carrying out any work, depressurise the product and all connection pipes.
- b) Securely prevent the pressure from being restored during work.



#### **⚠ CAUTION**

##### **Hot surfaces**

Burns of the skin on contact.

- a) At temperatures  $\geq 48$  °C allow the product to cool first.

## 9.2 Maintenance work



### TIP

#### Checking and documentation of the operating data

Regular checking and documentation of all operating data helps to detect faults at an early stage.

- Perform the maintenance work according to specifications.
- Replace defective or worn components.
- If necessary, request spare parts lists and assembly drawings from the manufacturer.
- Document the type and scope of the maintenance work along with the operating data.
- Compare the operating data with the values of the initial commissioning.  
In case of large deviations (> 10 %) determine the cause.
- Dispose of packaging materials and used parts according to local regulations.



### NOTICE

#### Protective devices and notes

After maintenance and/or repair, reattach all protective devices and notices removed in the process to their original position.

## 9.3 Maintenance instructions

The following information provides recommendations for maintenance work and maintenance intervals for the product in use.

Depending on the actual loads occurring during operation, the type, scope and interval of the maintenance work may deviate from the recommendations. A mandatory maintenance plan must be drawn up by the installer/operating company.



### TIP

In the course of preventive maintenance, it is advisable to replace wearing parts before the wear limit is reached.

With the appropriate know-how and sufficient equipment, the repair can also be carried out by the installer/operating company.

If necessary, request spare parts lists and assembly drawings from the manufacturer. Please consult the manufacturer for this purpose.



### NOTICE

#### Warranty

Any warranty will be void if not executed properly.

## 9.4 Maintenance table

### 9.4.1 Maintenance table

		First time after max. 24h	Daily	3000 operating hours	6000 operating hours	If necessary	Additional information
9.4.2	Check the operating pressure	2					
9.4.3	Check the media temperature	2					
9.4.4	Check the device temperature	2					
9.4.5	Check the function of the add-on valve	2					
9.4.6	Check the equipotential bonding	2					
9.4.7	Check the condition of the operating fluid	2					
9.4.8	Noise test unusual noises		1				
9.4.9	Cleaning		1				
9.4.10	Visual inspection of leakage		1				
9.4.2	Check the operating pressure			2			
9.4.3	Check the media temperature			2			
9.4.4	Check the device temperature			2			
9.4.5	Check the function of the add-on valve			2			
9.4.6	Check the equipotential bonding			2			
9.4.7	Check the condition of the operating fluid			2			
9.4.11	Visual check of the gearbox condition				3		
9.4.12	Visual check of the condition of housing parts				3		
9.4.13	Visual check of the condition of the plain bearings				3		
9.4.14	Visual check of the condition shaft seal				3		
9.4.15	Visual check of the condition of the outboard bearing				3		
9.4.16	Replacing the outboard bearing					3	
9.4.17	Replacing the plain bearings					3	
9.4.18	Replacing the shaft seal					3	
9.4.19	Replacing other seals					3	

1 - 0,1 h; 2 - 0,2 h; 3 - 0,75 h

## 9.4.2 Check the operating pressure

The operating pressure is indicated by the pressure gauges.

- If there is no operating pressure, check the individual components of the product.
- Comply with the product-specific data sheets/operating instructions.

## 9.4.3 Check the media temperature

The media temperature is measured through the temperature sensor.

The values are displayed by the built-in controller in the electrical control system.

- If the media temperature is too high or too low, check the product components.
- Comply with the product-specific data sheets/operating instructions.

## 9.4.4 Check the device temperature

Measure the surface temperature in the area of the bearing.

## 9.4.5 Check the function of the add-on valve

Add-on valves must be operated at regular intervals. This is necessary to ensure their faultless function.

## 9.4.6 Check the equipotential bonding

Check the equipotential bonding for tight fit and proper functioning.

## 9.4.7 Check the condition of the operating fluid

Pay attention to colour (dark colouring), odour and milky turbidity.

- Replace operating fluid if necessary.

## 9.4.8 Noise test unusual noises

In this case, attention must be paid to increased noise or uneven operation (pump unit).

- In case of unusual noises, examine the individual components of the product and line fixings and check the operating medium for foaming.
- Comply with the product-specific data sheets/operating instructions.

## 9.4.9 Cleaning

Remove dust deposits and dirt with a damp, clean cloth.

## 9.4.10 Visual inspection of leakage

Care must be taken here to ensure that there is no leakage from the connections.

- In the event of leaks in the connections, the glands must be tightened and, if necessary, the seals replaced.

### 9.4.11 Visual check of the gearbox condition

The driving shaft pinion and driven shaft pinion are wearing parts. In case of excessive wear, the parts or the pump must be replaced.

Important places to check are the surfaces opposite the shaft seal and bearing bushes, end faces of the driving shaft pinion and driven shaft pinion as well as the tooth flanks.

### 9.4.12 Visual check of the condition of housing parts

Important places to check are the end faces of the impeller chamber.

### 9.4.13 Visual check of the condition of the plain bearings

The plain bearings are wearing parts. In case of excessive wear, the parts or the pump must be replaced.

In case of multilayer plain bearings, the wear limit is reached if the bronze layer of the bearing is 50-70 % exposed.

When loaded on the suction side, the driving shaft pinion and driven shaft pinion are supported in the bearings so that wear is identified there first.

### 9.4.14 Visual check of the condition shaft seal

Pay attention to leak quantities and impermissible temperature increases.

- Small leaked quantities are indispensable for the function of the seal.
- In case of excessive leaked quantities or impermissible temperature increase, the pump must be shut down immediately. Replace the seal.

### 9.4.15 Visual check of the condition of the outboard bearing

The outboard bearing is a wearing part.

The life of the bearing primarily depends on the operating conditions.

The bearing should therefore be checked for damage after 4000 h at the latest. In the event of unacceptable wear, the bearing must be replaced.

Onsetting wear or pending failure can become noticeable due to increased heating of the bearing, increased power consumption, irregular running or even noise emissions.

### 9.4.16 Replacing the outboard bearing

With the appropriate know-how and adequate equipment, the repair can also be carried out by the installer/operating company.

To this end, if necessary, request spare parts and assembly drawings from the manufacturer.

Only use spare parts approved by the manufacturer.

### 9.4.17 Replacing the plain bearings

These are replaced only by the manufacturer.

Contact the manufacturer.

### 9.4.18 Replacing the shaft seal

With the appropriate know-how and adequate equipment, the repair can also be carried out by the installer/operating company.

To this end, if necessary, request spare parts and assembly drawings from the manufacturer.

Only use spare parts approved by the manufacturer.

### 9.4.19 Replacing other seals

With the appropriate know-how and adequate equipment, the repair can also be carried out by the installer/operating company.

To this end, if necessary, request spare parts and assembly drawings from the manufacturer.

Only use spare parts approved by the manufacturer.

# 10 Repair

## 10.1 Safety instructions for repairs



### **⚠ DANGER**

#### **Hazardous fluids**

Danger to life when handling hazardous fluids

- a) Comply with the safety data sheets and regulations on handling the hazardous fluids.
- b) Collect and dispose of hazardous fluids so that no hazard is created for persons or the environment.



### **⚠ DANGER**

#### **Rotating parts**

Risk to life due to entanglement or winding of parts of the body, hair or clothing items.

- a) Before carrying out any work, disconnect any drives and actuators from the power supply or depressurise them.
- b) Safely prevent restarting during the work.



### **⚠ WARNING**

#### **Failure of pressure bearing parts due to overload**

Risk of injury from flying parts.

Risk of injury due to splashing fluids.

- a) Before carrying out any work, depressurise the product and all connection pipes.
- b) Securely prevent the pressure from being restored during work.



### **⚠ CAUTION**

#### **Hot surfaces**

Burns of the skin on contact.

- a) At temperatures  $\geq 48$  °C allow the product to cool first.

## 10.2 General

Corrective maintenance includes:

1. Troubleshooting  
Finding damage, determining and localising the cause of the damage.
2. Damage repair  
Removing the primary causes and replacing or repairing defective components. Repairs are generally carried out by the manufacturer.

### Repair by the manufacturer

Before returning the product, fill out the return form. The form can be filled out online and is available to download as a pdf file or can be requested from the manufacturer.



### NOTICE

#### Device contains hazardous substances

If the device has been operated with hazardous fluids it must be cleaned before it is returned. If this is not possible, the safety data sheet of the hazardous material must be provided in advance.

#### Repair by the installer/operating company

With the appropriate know-how and sufficient equipment, the repair can also be carried out by the installer/operating company. Please consult the manufacturer for this purpose.

- a) If necessary, request spare parts lists and assembly drawings from the manufacturer.
- b) Only use spare parts approved by the manufacturer.
- c) Dispose of packaging materials and used parts according to local regulations.



### NOTICE

#### Warranty

Any warranty will be void if not executed properly.



### NOTICE

#### Protective devices and notes

After maintenance and/or repair, reattach all protective devices and notices removed in the process to their original position.



### 10.3 Fault table

<b>Fault</b>	<b>Potential causes</b>	<b>Possible measures</b>
<b>Increased noise</b>		
Pump cavitation	Excessive negative pressure (not complete filling of the pump)	Check suction line design Use noise-optimised pump
	Suction line clogged	Clean the suction line
	Suction filter plugged or too small	Clean suction filter or use a larger filter
		Replace filter element
	Suction basket plugged or too small	Clean intake strainer or dimension larger
	Fluid temperature too low	Adjust the temperature of medium
Foaming or air in media	Pump does not suck	Check the oil level in the tank
		Check suction line
		Check the shaft seal
	Shaft seal defective	Replace seals
	Suction connection leaking	Tighten or replace the screw connections
		Replace seals
	System not vented	Vent the system
Return line ends above the fluid level	Extend return line	
Heavy foaming in the system, e.g. in gears	Use noise-optimised pump	
Mechanical vibrations	Incorrectly aligned and/or loose coupling	Correct the alignment of the coupling and secure the coupling halves
	Incorrectly and/or insufficient line fastening	Fixate lines with suitable fastening material (e.g. pipe clamps)
	Wobbling pressure relief valve	Increase valve opening pressure
	Not a noise-reducing setup	Use dampers
<b>Pump does not suck</b>		
	Dry run	Fill pump and the suction line with medium
	Minimum filling level in the reservoir tank undercut	Refill media
	Wrong direction of rotation	Correct the direction of rotation
	Throttled/closed shut-off element in the suction line	Open the shut-off element
	Suction line clogged	Clean the suction line

<b>Pump does not suck</b>		
	The air in the suction line cannot be compressed in the pressure line	Reduce the start-up pressure
		Vent the pressure line
		Increase volume of the pressure line
	Speed of the pump is too low	Check the pump design
		During frequency inverter operation: Check the operation/line frequency
	Geodetic suction head too high	Check installation location
Provide pre-filling pump		
<b>Insufficient pressure</b>		
<b>Insufficient pumping flow rate</b>		
	Excessive negative pressure (not complete filling of the pump)	Check suction line design
	Too high media viscosity	Provide pre-filling pump
	Speed of the pump is too low	Check the pump design
		During frequency inverter operation: Check the operation/line frequency
	Throttled/closed shut-off element in the suction line	Open the shut-off element
	Suction line clogged	Clean the suction line
	Suction filter plugged or too small	Clean suction filter or use a larger filter
		Replace filter element
	Suction basket plugged or too small	Clean intake strainer or dimension larger
	Constant triggering of pressure relief valve (if existing)	Increase valve opening pressure
	Pump does not suck	Check the oil level in the tank
		Check suction line
Check the shaft seal		
Wear	Replace the device	
<b>Excessive operating temperature</b>		
	Cooling and heat dissipation insufficient	Increase the cooling capacity
	Not sufficient oil in the system	Check the container layout
	Excess fluid is being delivered into the supply tank via pressure relief valve under load	Check the pump design

<b>Impermissible pump heating</b>		
	Constant triggering of pressure relief valve (if existing)	Increase valve opening pressure
	Pressure too high in association with a media viscosity that is too low	Check the system design
	Speed too fast in connection with media viscosity that is too high	Check the system design
	Gland lid overtightened (for gland seal)	Unscrew gland lid and readjust leakage
	Suction pressure too high	Reduce the pressure
	Wear	Replace the device
<b>Leakage</b>		
Seal failure	Lack of maintenance	Comply with maintenance intervals
		Replace seals
	Mechanical damage	Replace seals
	Thermal overload	Check operating data
		Replace seals
	Pressure too high	Check operating data
		Replace seals
	Gas content in media too high	Check operating data
		Replace seals
	Corrosion/chemical degradation	Check material compatibility
Replace seals		
Wrong direction of rotation	Correct the direction of rotation	
	Replace seals	
Contaminated medium	Provide filtration	
	Replace seals	
Gland lid not sufficiently tightened (for gland seal)	Retighten gland lid	
Loose screw connection	Tighten or replace the screw connections	
<b>Coupling</b>		
Coupling wear	Alignment error	Correct the alignment of the coupling and secure the coupling halves
	Spider overloaded	Check operating data
		Use harder spider
Cam break	Spider wear Torque transmission due to metal contact	Adapt maintenance intervals
		Replace coupling

Premature spider wear	Alignment error	Correct the alignment of the coupling and secure the coupling halves
		Replace spider
	Spider failure due to chemical corrosion	Check material compatibility
		Replace spider
<b>Motor protection switch tripped</b>		
	Driving power too low	Check the drive design
	Motor incorrectly connected	Check motor connection
	Phase failure	Check feed/supply
	Current consumption too high	Check operating data
		Check direction of rotation
Motor circuit breaker incorrectly designed	Check operating data	
Consult the manufacturer in the event of unidentifiable faults		