

KRACHT

D.0038410002

Operating instructions (Translation)

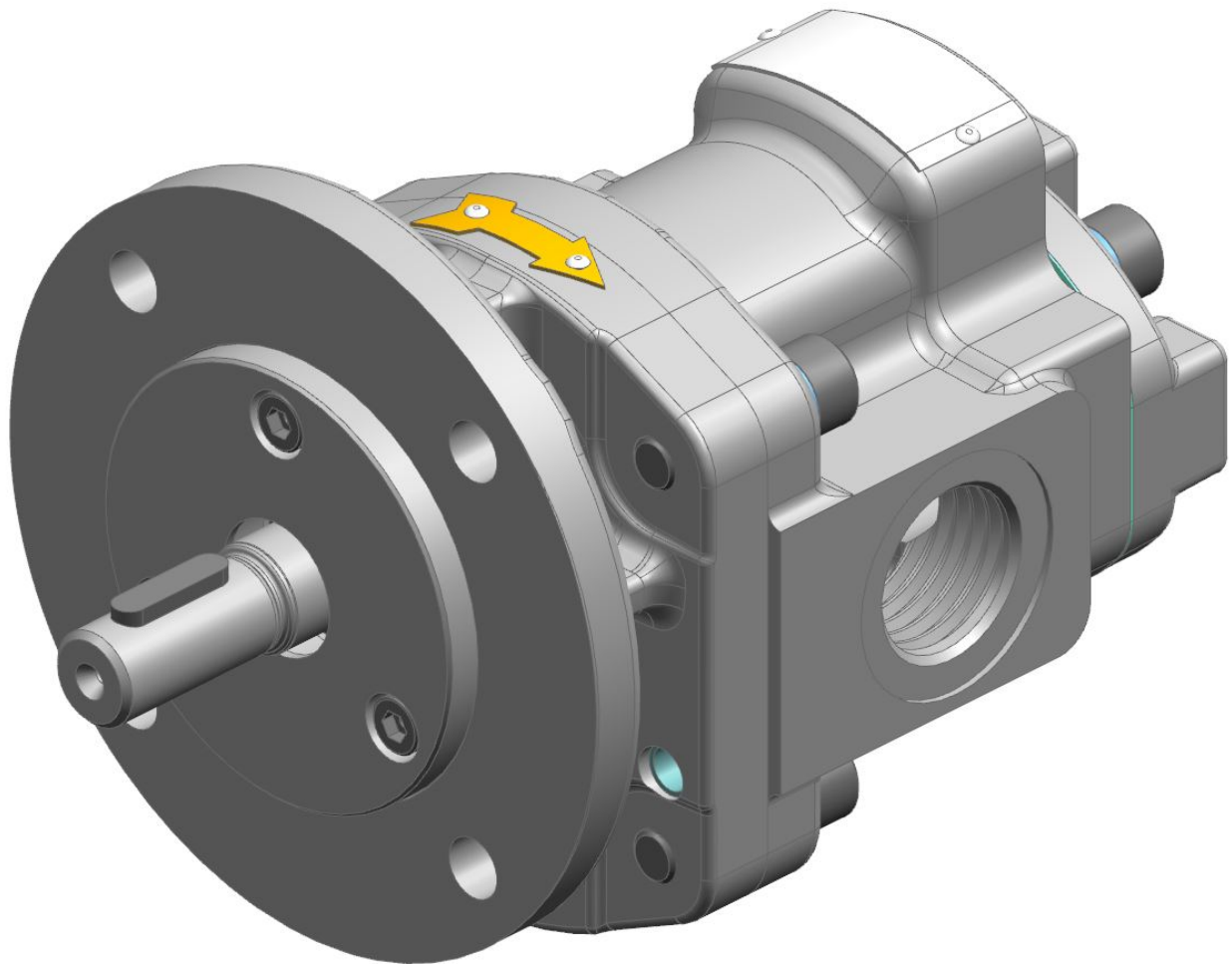

Gear pump KF 1-coated
Magnetic coupling MINEX® -S
English

Table of content

| | | |
|----------|---|-----------|
| 1 | General | 5 |
| 1.1 | About the documentation | 5 |
| 1.2 | Manufacturer address..... | 5 |
| 1.3 | Applicable documents..... | 5 |
| 1.4 | Symbols..... | 6 |
| 2 | Safety | 7 |
| 2.1 | Intended use..... | 7 |
| 2.2 | Foreseeable misuse | 7 |
| 2.3 | Personnel qualification and training..... | 7 |
| 2.4 | Basic safety instructions..... | 8 |
| 2.5 | Fundamental hazards..... | 8 |
| 2.6 | Special hazards..... | 10 |
| 3 | Device description | 11 |
| 3.1 | Functional principle | 11 |
| 3.1.1 | Magnetic coupling | 12 |
| 3.2 | Possible versions..... | 13 |
| 3.2.1 | Magnetic coupling | 15 |
| 3.3 | Type key | 16 |
| 3.3.1 | Type key magnetic coupling | 17 |
| 3.4 | Rotation and delivery direction | 18 |
| 3.5 | Special number..... | 18 |
| 3.6 | Free shaft end | 19 |
| 4 | Technical data | 20 |
| 4.1 | General | 20 |
| 4.2 | Nominal sizes..... | 21 |
| 4.3 | Viscosity - Rotation speed assignment..... | 21 |
| 4.4 | Permissible pressure range..... | 22 |
| 4.4.1 | Operating pressure of suction side and pressure side..... | 22 |
| 4.5 | Permissible temperature range..... | 23 |
| 4.5.1 | Gear pump with magnetic coupling..... | 24 |
| 4.6 | Material data | 24 |
| 4.7 | Weight | 25 |
| 4.8 | Dimensions | 25 |

| | | |
|----------|--|-----------|
| 5 | Transport and storage | 26 |
| 5.1 | General | 26 |
| 5.2 | Transport..... | 26 |
| 5.3 | Storage | 26 |
| 5.4 | Storage conditions..... | 27 |
| 5.5 | Special hazards | 28 |
| 6 | Installation | 29 |
| 6.1 | Safety instructions for installation | 29 |
| 6.1.1 | Special hazards | 31 |
| 6.2 | Noise reduction..... | 31 |
| 6.3 | Mechanical installation..... | 32 |
| 6.3.1 | Preparation..... | 32 |
| 6.3.2 | Gear pump for magnetic coupling..... | 32 |
| 6.4 | Connection lines | 34 |
| 6.4.1 | General..... | 34 |
| 6.4.2 | Suction line..... | 34 |
| 6.4.3 | Pressure line..... | 36 |
| 6.4.4 | Mounting Connection lines | 36 |
| 6.5 | Change of the direction of rotation | 36 |
| 7 | Operation start-up | 37 |
| 7.1 | Safety instructions for start-up | 37 |
| 7.2 | Special hazards..... | 38 |
| 7.3 | Preparation..... | 39 |
| 7.4 | Pressure relief valve adjustment..... | 39 |
| 7.4.1 | Pressure relief valve | 40 |
| 7.5 | Further operation start-up..... | 40 |
| 8 | Removal..... | 41 |
| 8.1 | Safety instructions for removal | 41 |
| 8.2 | Special hazards..... | 42 |
| 8.3 | Removal..... | 43 |
| 9 | Maintenance | 44 |
| 9.1 | Important notes about explosion protection | 44 |
| 9.2 | Special hazards..... | 45 |
| 9.3 | Maintenance work..... | 46 |
| 9.4 | Maintenance instructions | 46 |
| 9.5 | Maintenance table | 47 |
| | Maintenance table..... | 47 |
| 9.5.1 | Inspection: Discharge flow | 48 |
| 9.5.2 | Inspection: Operating pressure | 48 |
| 9.5.3 | Inspection: Media temperature | 48 |
| 9.5.4 | Inspection: Device temperature | 48 |
| 9.5.5 | Inspection: Add-on valve function (if existing)..... | 48 |
| 9.5.6 | Inspection: Check the potential compensation (if existing) | 48 |

| | | |
|-----------|--|-----------|
| 9.5.7 | Inspection: Condition of operating fluid | 48 |
| 9.5.8 | Audiometric monitoring: Unusual noise..... | 48 |
| 9.5.9 | Visual inspection: Leakages | 49 |
| 9.5.10 | Visual inspection: Filling level of liquid seal (if existing)..... | 49 |
| 9.5.11 | Visual inspection: Condition gears..... | 49 |
| 9.5.12 | Visual inspection: Condition of housing parts..... | 49 |
| 9.5.13 | Visual inspection: Condition of plain bearings..... | 49 |
| 9.5.14 | Visual inspection: Condition of shaft seal | 49 |
| 9.5.15 | Replacing: Outboard bearings..... | 50 |
| 9.5.16 | Replacing: Plain bearings (only by manufacturer) | 50 |
| 9.5.17 | Replacing: Shaft seal..... | 50 |
| 9.5.18 | Replacing: Other seals..... | 50 |
| 10 | Repairs..... | 51 |
| 10.1 | Safety instructions for repair..... | 51 |
| 10.2 | Special hazards..... | 52 |
| 10.3 | General | 53 |
| 10.4 | Detecting and eliminating failures..... | 54 |

1 General

1.1 About the documentation

These operating instructions describe the installation, operation and maintenance of the following device:

Gear pump KF 1

Magnetic coupling MINEX® -S

These operating instructions are a component of the device and must be kept accessible for the personnel near the device at all times.

The device is manufactured in different versions. Information about the version concerned in the individual case can be found on the device's type plate.

If you have any questions about these operating instructions, please contact the manufacturer.

1.2 Manufacturer address

KRACHT GmbH

Gewerbestraße 20

DE 58791 Werdohl

Tel: +49 2392 935-0

Fax: +49 2392 935-209

E-Mail: info@kracht.eu

Web: www.kracht.eu

1.3 Applicable documents

In addition to these instructions, also observe the corresponding instructions for the existing or planned systems or system parts.

1.4 Symbols



DANGER

Identification of an immediate hazard, which would result in death or severe bodily injury if not avoided.



WARNING

Identification of a potential medium risk hazard, which would lead to death or severe bodily injury if not avoided.



CAUTION

Identification of a low risk hazard, which could lead to minor or medium bodily injury if not avoided.

ATTENTION

Flagging of notices to prevent property damage.



NOTICE

Identification of basic safety instructions.
Non-compliance can lead to hazards for people and the device.



TIP

Flagging of special user tips and other especially useful or important information.

2 Safety

2.1 Intended use

1. The device has been designed for operation with fluid.
Dry operation is not permitted.
2. The product may only be operated when completely filled.
3. The fluid must be compatible with the materials used in the product. Chemical expertise is required for that. Be careful with ethylene oxide or other catalytically or exothermically reacting or self-decomposing substances. Please consult the manufacturer in cases of doubt.
4. The product may only be used in normal industrial atmospheres.
If there are any aggressive substances in the air, always consult the manufacturer.
5. The product may only be operated in compliance with these operating instructions and the applicable documents.
Deviating operating conditions require the express approval of the manufacturer.
6. The device may be operated in connection with a magnetic coupling.
7. Use of the product for purposes other than those for which it is intended invalidates any warranty.

2.2 Foreseeable misuse

The manufacturer is not liable for damage resulting from non-intended or improper use.

2.3 Personnel qualification and training

The personnel designated to assemble, operate and service the device must be properly qualified.

This can be through training or specific instruction.

Personnel must be familiar with the contents of this operating instructions.



NOTICE

Read the operating instructions thoroughly before use.

2.4 Basic safety instructions



NOTICE

Basic safety instructions

Non-compliance can lead to hazards for people and the unit.

- a) Follow existing regulations for accident prevention and safety at work as well as the internal regulations of the operating company.
- b) Ensure the greatest possible cleanliness.
- c) Wear suitable personal protective equipment.
- d) Do not remove type plates or other information or make them illegible or unrecognisable.
- e) Do not make any technical modifications.
- f) Comply with maintenance intervals.
- g) Only use spare parts approved by the manufacturer.

2.5 Fundamental hazards



⚠ DANGER

Hazardous fluids

Danger to life when handling hazardous fluids.

- a) Comply with the safety data sheets and regulations on handling the hazardous fluids.
- b) Collect and dispose of hazardous fluids so that no hazard is created for persons or the environment.



⚠ DANGER

Hazardous fluids

Danger to life when handling hazardous fluids.

- a) Defective components and connection lines must be replaced or fixed without delay.
- b) Use only components and connection lines approved for the expected pressure range.



⚠ DANGER

Rotating parts!

Danger of death due to body parts, hair or clothing getting trapped or entangled.

- a) Before all work, ensure that existing drives are voltage-free and pressure-free.
- b) Securely prevent restarting during all work.

**⚠ DANGER****Rotating parts**

Danger of death due to body parts, hair or clothing getting trapped or entangled.

- a) Take measures against accidental touching of rotating parts.

**⚠ WARNING****Rotating parts!**

Danger of injury from flying parts.

- a) Enclose rotating parts so as to avoid any danger from flying parts in the event of breakage or malfunction.

**⚠ WARNING****Failure of pressure bearing parts due to overload**

Risk of injury from flying parts.

Risk of injury due to splashing fluids.

- a) Depressurize the system before all work.
- b) Securely prevent the pressure from being restored during work.

**⚠ WARNING****Failure of pressure bearing parts due to overload**

Risk of injury from flying parts.

Risk of injury due to fluid spurting out.

- a) Use only connections and lines approved for the expected pressure range.
- b) Securely prevent the permissible pressures from being exceeded, e.g. by using pressure relief valves or bursting discs.
- c) Pipelines must be designed in such a way that no tension e.g. caused by changes in length due to fluctuations in temperature can be transferred to the product.

**⚠ WARNING****Failure of pressure bearing parts due to overload**

Risk of injury from flying parts.

Risk of injury due to fluid spurting out.

- a) Do not operate the product with shut-off devices closed.
- b) Securely prevent the restoration of pressure while working on the device.

2.6 Special hazards



DANGER

Powerful magnetic field

Danger of death for people with heart pacemakers

- a) Maintain a safety clearance of at least 2 m to the unmounted components of the magnetic coupling.
- b) Maintain a safety clearance of at least 0.5 m to assembled couplings with axially aligned magnetic rotors and surrounding coupling housing (bell housing).



WARNING

Powerful magnetic field

Danger of injury due to uncontrolled mutual attraction of magnetic parts or parts that can be magnetized.

- a) When performing any work, bear in mind the magnetic forces which occur, especially within 0.5 m of the magnetic coupling.

ATTENTION

Powerful magnetic field

Magnetic data carriers (discs, credit cards, etc.) can be damaged or erased by magnetic fields.

- a) Maintain a minimum clearance of 1 m to the magnetic field.

3 Device description

3.1 Functional principle

Pumps of this series are external gear pump types that work according to the positive displacement principle.

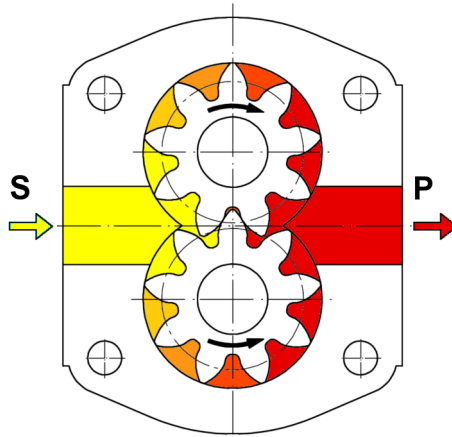

- S Suction connection
- P Pressure connection

When rotated, two gearwheels meshing together produce a volume enlargement as a result of the opening of the tooth spaces on the suction side (S), so that medium can flow in and so that a corresponding volume is displaced simultaneously by immersion of the teeth into the filled tooth spaces on the pressure side (P). Fluid transport takes place through entrainment in the tooth gaps along the wall of the wheel chamber. The so-called geometric flow rate V_g is being displaced per wheel rotation. A value that is stated in technical documents as rated volume V_{gn} to specify the pump size.

The displacement cycle describe initially takes place without exhibiting appreciable pressure build-up. Only after setting external loads, for example, through delivery heights, flow resistances, line elements, etc. will the required working pressure arise to overcome these resistances.

The pressure occurring at the shaft seal therefore corresponds to the pressure at the suction connection of the device. The permissible pressure is determined by the type of sealing.

3.1.1 Magnetic coupling

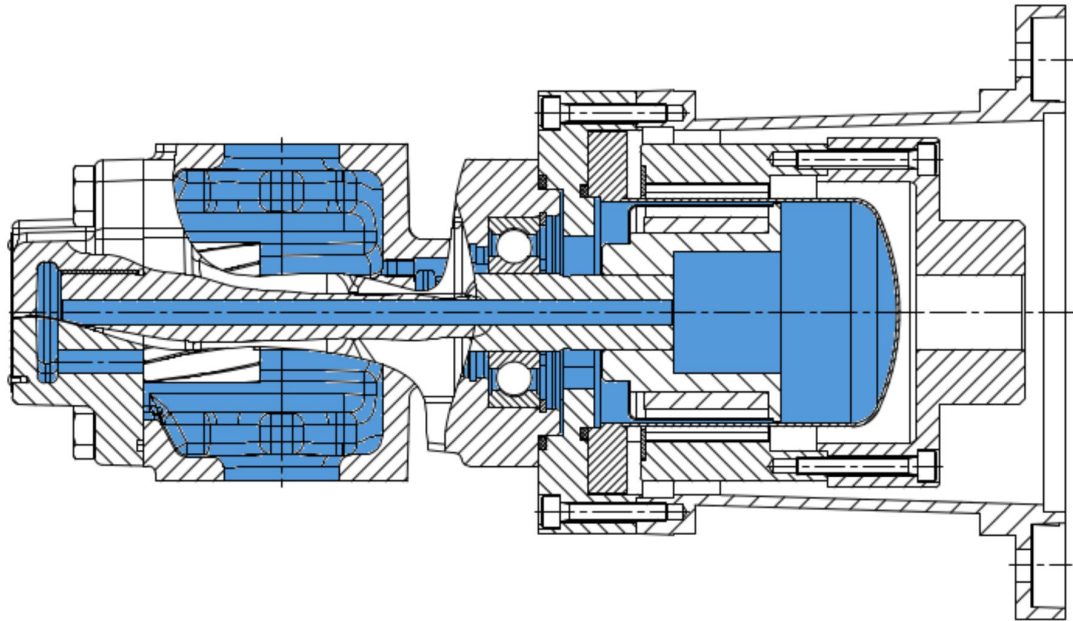

Versions with magnetic coupling are used when absolute leak-proofness is required on the shaft seal or when being operated with supply pressure on the suction side. The magnetic coupling is leak-proof within the permissible technical limits.

This magnetic coupling has the exterior rotor installed on the motor shaft and the interior rotor on the pump shaft. The torque is transmitted between the two rotors via magnetic force. A separating can installed in-between the two rotors provides hermetic sealing of the pump.

The device can be used in vacuum mode, e.g. for filling brake fluid, while doing so, the penetration of air into the system is reliably prevented. Leakagefree operation is ensured during operation in closed systems that have the system pressure applied on the suction side.

On versions with rinsing, an internal forced rinsing of the interior rotor by the pumping medium is provided for continuous removal of the heat developing in the air gap. The magnetic coupling is cooled by a substream of the pumping medium.

3.2 Possible versions

Gear pump

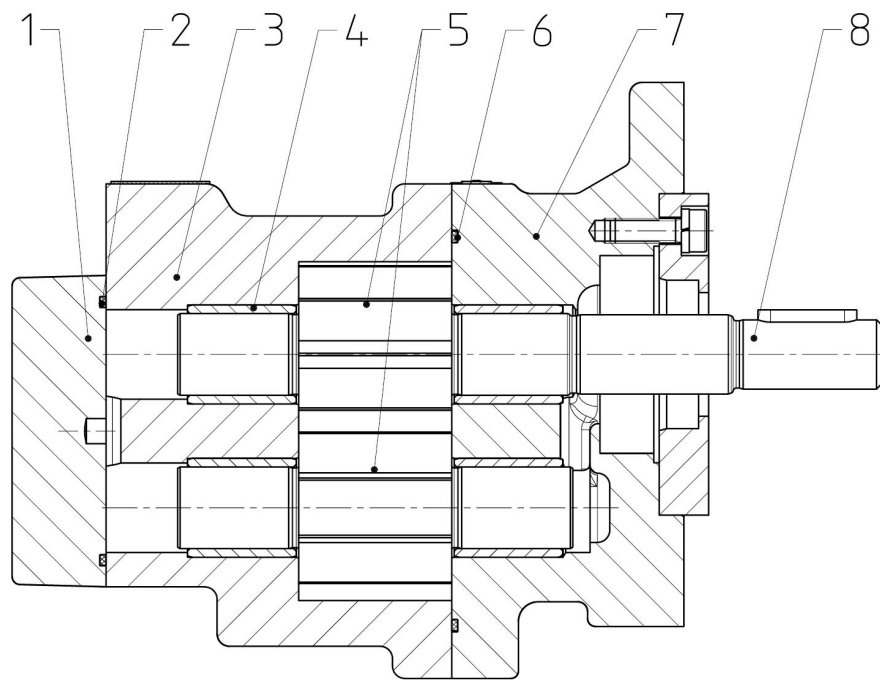

1 End cover

3 Housing

5 Gears

7 Flange cover

2 O-ring

4 Plain bearing bush

6 O-ring

8 End of drive shaft

Gear pump with pressure relief valve

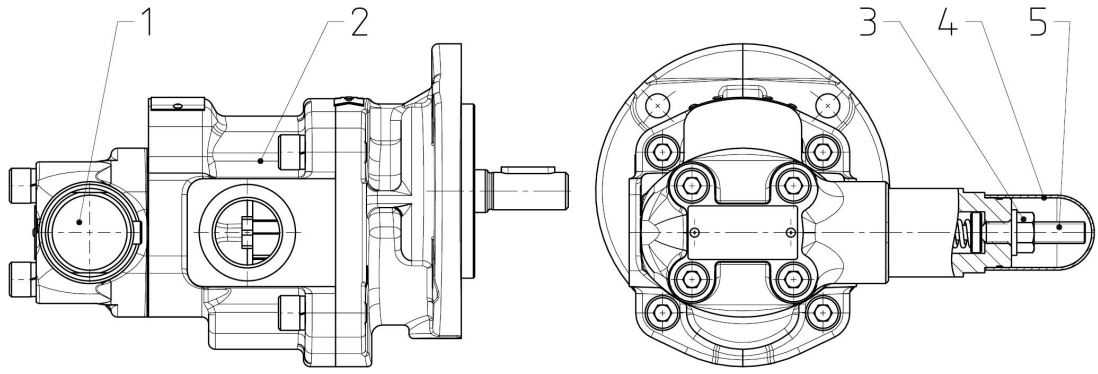

- 1 Pressure relief valve
- 3 Collar nut
- 5 Adjustment screw

- 2 Gear pump
- 4 Cover

Version cover

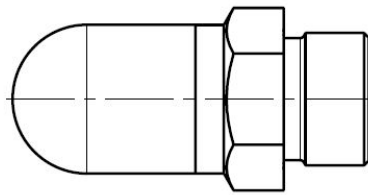

Thread protective cap

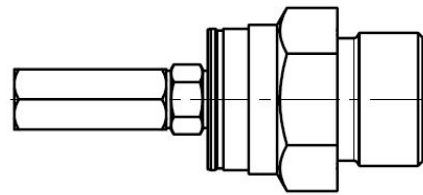

Cap nut KN17

3.2.1 Magnetic coupling

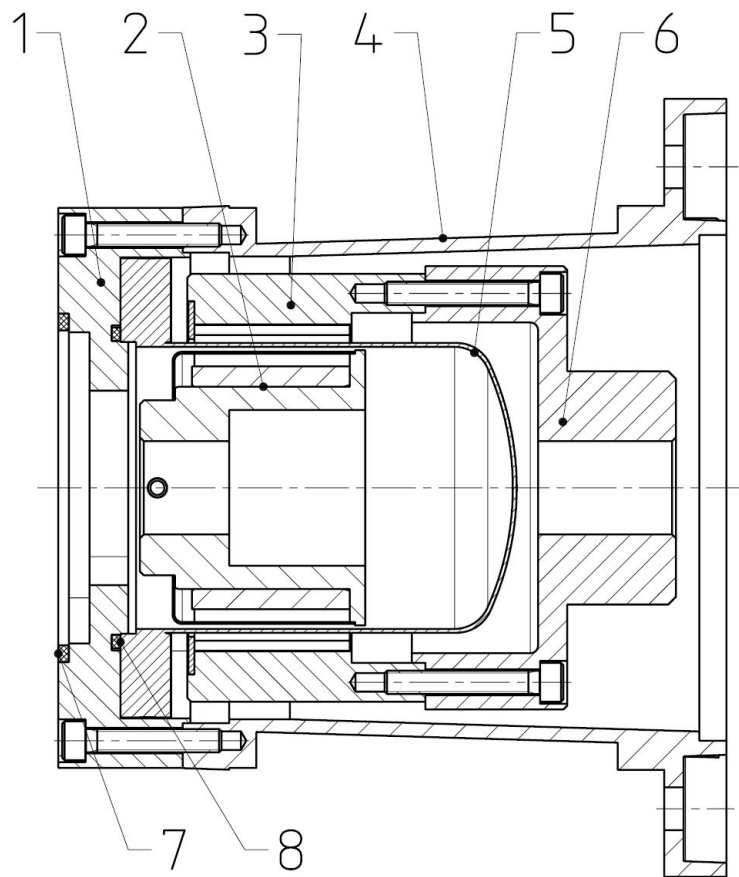

- | | |
|----------------------|------------------|
| 1 Adapter flange | 2 Internal rotor |
| 3 External rotor | 4 Bell housing |
| 5 Containment shroud | 6 Flange hub |
| 7 O-ring | 8 O-ring |

3.3 Type key

| Ordering example | | | | | | | | | | | | | | |
|---|----|----|---|----|----|----|----------|----|-----|---|-----|-----|-----|------|
| KF | 1/ | 4 | D | 1 | 0 | K | P | 0 | A | 0 | D | E | 65 | /100 |
| 1. | 2. | 3. | 4. | 5. | 6. | 7. | 8. | 9. | 10. | 11. | 12. | 13. | 14. | 15. |
| Ordering example | | | | | | | | | | | | | | |
| + | | | DKF 1 | | | | D | | | 04 | | | | |
| | | | 16. | | | | 17. | | | 18. | | | | |
| Explanation of type key | | | | | | | | | | | | | | |
| 1. Product name | | | | | | | | | | | | | | |
| 2. Size | | | | | | | | | | | | | | |
| 1 | | | | | | | | | | | | | | |
| 3. Nominal size | | | | | | | | | | | | | | |
| V_{gn} | | | 4; 8; 11; 16; 20; 24 | | | | | | | | | | | |
| 4. Flange mounting cover | | | | | | | | | | | | | | |
| D | | | KF 1/. | | | | | | | | | | | |
| 5. Direction of rotation | | | | | | | | | | | | | | |
| 1 | | | Clockwise | | | | 2 | | | Counterclockwise | | | | |
| 6. Outboard flange | | | | | | | | | | | | | | |
| 0 | | | Without Outboard flange | | | | | | | | | | | |
| 7. Construction of housing | | | | | | | | | | | | | | |
| K | | | Housing with threaded connection | | | | | | | | | | | |
| 8. Driving shaft | | | | | | | | | | | | | | |
| P | | | Cylindrical shaft end | | | | | | | | | | | |
| 9. 2nd shaft end | | | | | | | | | | | | | | |
| 0 | | | Without 2nd shaft end | | | | | | | | | | | |
| 10. End cover | | | | | | | | | | | | | | |
| A | | | only for only for direction of rotation 1 or 2 | | | | 0 | | | Without End cover (for valve installation) | | | | |
| 11. Design serial number (specified by manufacturer) | | | | | | | | | | | | | | |
| 12. Housing material and plain bearing | | | | | | | | | | | | | | |
| D | | | EN-GJL-250 (GG-25) Multi layer friction bearings contains lead | | | | V | | | EN-GJS-400-15 (GGG-40) Multi layer friction bearings contains lead | | | | |
| 13. Gears version | | | | | | | | | | | | | | |
| E | | | Geom. tooth volume | | | | | | | | | | | |
| 15. Special number | | | | | | | | | | | | | | |
| Special number [▶ 18] | | | | | | | | | | | | | | |
| 16. Pressure relief valve | | | | | | | | | | | | | | |
| DKF 1 | | | KF 1/. | | | | | | | | | | | |

| Explanation of type key | | | |
|------------------------------------|-----------------------|-----------|--------------------|
| 17. Version DKF-valve | | | |
| C | Housing material : | D | Housing material : |
| | EN-GJL-250 (GG-25) | | EN-GJL-250 (GG-25) |
| | Pump side seal | | Pump side seal |
| | Other seals | | Other seals |
| O-ring Copper | O-ring FKM | | |
| Cover : | Cover : | | |
| Cap nut KN17 | Thread protective cap | | |
| 18. Pressure setting ranges | | | |
| 04 | 2 – 4 bar | 16 | 8 – 16 bar |
| 08 | 4 – 8 bar | 25 | 16 – 25 bar |

3.3.1 Type key magnetic coupling

| Ordering example | | | | | | |
|------------------|---|----------|---|----------|---|------------|
| MSC75 | - | A | - | 2 | - | FKM |
| 1. | | 2. | | 3. | | 4. |

| Explanation of type key | | | |
|--|--------|----------|--------|
| 1. Coupling size | | | |
| MSA46 ; MSA60 ; MSB60 ; MSA75 ; MSB75 ; MSC75 ; MSB110 ; MSC110 ; MSC110S ; MSC135 ; MSC135S ; MSD135 ; MSD135S ; MSD165 ; MSE165 ; MSD200 | | | |
| 2. Max. operating pressure | | | |
| A | 150 °C | B | 300 °C |
| 3. Pressure range | | | |
| 1 | 16 bar | 3 | 40 bar |
| 2 | 25 bar | 4 | 60 bar |
| 4. Material O-ring | | | |

3.4 Rotation and delivery direction

The direction of rotation is indicated by the bent arrow, Looking at the end of drive shaft.

The flow direction is indicated by the straight arrows.

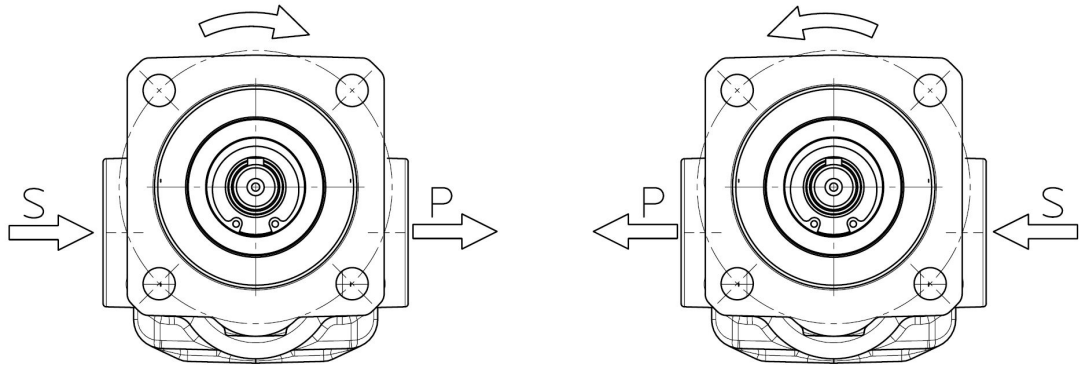

S = Suction connection

P = Pressure connection

3.5 Special number

| Special number | Description |
|----------------|---|
| 100 | Wear protection coating on gear and plain bearing bush (Chem. nickel-plated with SiC deposits) |
| 303 | Version for higher pressure; $\Delta p = 35$ bar Viscosity up to approx. $100 \text{ mm}^2/\text{s}$. |

3.6 Free shaft end

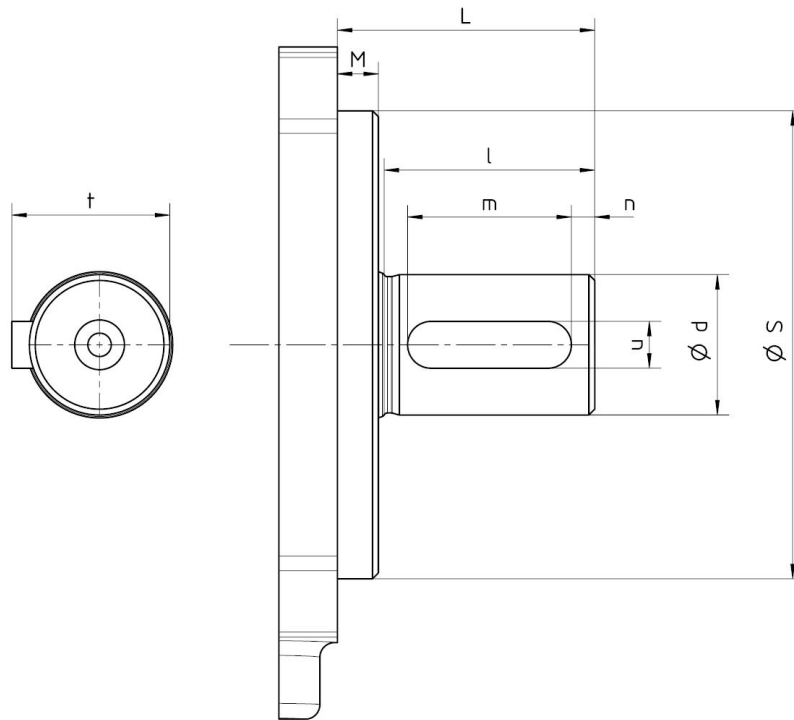

| Nominal size | L | S _{h6} | M | d _{j6} | l | m | n | t | u |
|------------------|----|-----------------|---|-----------------|----|----|---|----|---|
| KF 1/4 - KF 1/24 | 40 | 65 | 5 | 14 | 30 | 20 | 5 | 16 | 5 |

4 Technical data

4.1 General

| General information | | |
|--|--|---|
| Housing connection ⁽¹⁾ | KF 1/4 | Whitworth pipe thread G1/2 |
| | KF 1/8 - KF 1/24 | Whitworth pipe thread G3/4 |
| Mounting position | KF 1/. | Any |
| External loads on shaft end | Axial and radial forces are not allowed. | |
| Speed | n | Viscosity - Rotation speed assignment [▶ 21] |
| Operating pressure | p_e p_b | Permissible pressure range [▶ 22] |
| Viscosity | v_{min} | 12 mm ² /s |
| | v_{max} | Consult the manufacturer |
| Fluid temperature | ϑ_m | Permissible temperature range [▶ 23] |
| Ambient temperature | ϑ_u | Permissible temperature range [▶ 23] |
| Filtering | β | ≤ 60 μm |
| Material | Material data [▶ 24] | |
| Permissible media | Lubricating fluids without abrasive components Example : PUR components, plasticizers, resins, adhesives, varnishes, paints, mineral oils, synthetic oils Liquids with magnetizable components are not permitted (Petrols, solvents, etc. are not permissible) | |
| ⁽¹⁾ Pipe thread : ISO 228-1 | | |

| Magnetic coupling | | | | |
|-------------------|----------------------------|--------------------------|--------------------------|--------------------------|
| Coupling size | Rated torque [Nm] at 20 °C | | | |
| | Pressure range 16 bar | Pressure range 25 bar | Pressure range 40 bar | Pressure range 60 bar |
| MSA46 | 3 | - | - | - |
| MSA60 | - | - | 7 | - |
| MSB60 | - | - | 14 | - |
| MSB75 | - | 24 | - | - |
| MSC75 | 40 | 40 | - | 40 |

4.2 Nominal sizes

| Nominal size V_{gn} | Geom. displacement V_g [cm ³ /rev.] | Speed n | | Mass inertia x 10 ⁻⁴ J [kg m ²] |
|--------------------------|---|--------------------|--------------------|---|
| | | n_{min} [rpm] | n_{max} [rpm] | |
| KF 1/4 | 4.6 | 200 | 2000 | 0.2 |
| KF 1/8 | 8.3 | | | 0.35 |
| KF 1/11 | 11.3 | | | 0.45 |
| KF 1/16 | 16.6 | | | 0.65 |
| KF 1/20 | 20.5 | | | 0.75 |
| KF 1/24 | 24.8 | | | 0.87 |

4.3 Viscosity - Rotation speed assignment

| Kinematic viscosity ν [mm ² /s] | Recommended rpm n [rpm] |
|--|-------------------------|
| 200 | 20000 |
| 250 | 15000 |
| 300 | 10000 |
| 450 | 6000 |
| 650 | 3000 |
| 800 | 2000 |
| 1200 | 1000 |
| 1800 | 500 |
| 2000 | 400 |



TIP

Select the speed of rotation so that complete filling of the pump is ensured. This is given if the pressure on the suction side does not fall below the permissible pressure $p_{e \min}$.

4.4 Permissible pressure range

4.4.1 Operating pressure of suction side and pressure side

| Gear pump | | | | |
|--------------------------|--|-------------------------|---|---|
| Nominal size V_{gn} | Operating pressure | | | |
| | suction side | | pressure side | |
| | $p_{e\ min}$ [bar abs.] | $P_{e\ max}$ [bar rel.] | p_b [bar rel.] (perm. continuous pressure) | $p_{b\ max}$ [bar] (Maximum pressure) ⁽²⁾ |
| KF 1/4 - KF 1/20 | 0,6 ⁽¹⁾ | 40 | 50 | 60 |
| KF 1/24 | Vacuum equipment: 0.08 Standing still: 0 | | | 50 |

⁽¹⁾ Start-up condition: 0.4 bar absolute (max. 30 minutes)

⁽²⁾ Maximum pressure: only applicable when using mineral oil at speeds of > 700 1/min and viscosity values of 30 mm²/s - 1000 mm²/s.

| Gear pump with Magnetic coupling | | | | | |
|----------------------------------|-------------------------------------|---|-------------------------|---|--|
| Nominal size V_{gn} | Pressure range Magnetic coupling | Operating pressure | | | |
| | | suction side | | pressure side | |
| | | $p_{e\ min}$ [bar abs.] | $P_{e\ max}$ [bar rel.] | p_b [bar rel.] (perm. continuous pressure) | $p_{b\ max}$ [bar] (Maximum pressure) |
| KF 1/4 - KF 1/20 | 1 | 0.6 ⁽¹⁾ Vacuum equipment: 0.08 | 16 | 50 | 60 |
| | 2 | | 25 | | |
| | 3 | | 40 | | |
| | 4 | | 60 | | |
| KF 1/24 | 1 | Standing still: 0 | 16 | 50 | 50 |
| | 2 | | 25 | | |
| | 3 | | 40 | | |
| | 4 | | 50 | | |

⁽¹⁾ Start-up condition: 0.4 bar absolute (max. 30 minutes)

4.5 Permissible temperature range

| Sealing material | Fluid temperature ϑ_m | |
|--------------------------|---------------------------------|---------------------------|
| | $\vartheta_{m \min}$ [°C] | $\vartheta_{m \max}$ [°C] |
| CR | -20 | 100 |
| EPDM | | 120 |
| FEP with FKM-core | | 200 |
| FFKM / FEP with FKM-core | | 200 |
| FKM | | 150 |
| HNBR | | 90 |
| NBR | | 200 |
| PTFE / FEP with FKM-core | | 200 |
| FKM (Low temperature) | | -30 |

| Sealing material | Ambient temperature ϑ_u | |
|--------------------------|-----------------------------------|---------------------------|
| | $\vartheta_{u \min}$ [°C] | $\vartheta_{u \max}$ [°C] |
| CR | -20 | 60 |
| EPDM | | |
| FEP with FKM-core | | |
| FFKM / FEP with FKM-core | | |
| FKM | | |
| HNBR | | |
| NBR | | |
| PTFE / FEP with FKM-core | | |
| FKM (Low temperature) | | |



NOTICE

Comply with media-specific properties

4.5.1 Gear pump with magnetic coupling

| Sealing material | Fluid temperature ϑ_m | | |
|------------------------|----------------------------------|----------------------------------|-----|
| | $\vartheta_{m \text{ min}}$ [°C] | $\vartheta_{m \text{ max}}$ [°C] | |
| | | Max. operating pressure | |
| | | A | B |
| CR | -20 | 100 | 100 |
| EPDM | | 130 | 130 |
| FEP with FKM-core | | 150 | 200 |
| FKM | | 150 | 150 |
| HNBR | | 90 | 90 |
| NBR | | | |
| FKM (Low temperature) | -30 | 150 | 150 |

ATTENTION

Eddy current losses

Metal separating cans in a magnetic coupling will always induce eddy current losses within the rotating magnetic field that are converted into heat.

- a) When using pump design variants without circulating fluid, be sure to account for increases in temperature caused by eddy current losses.

4.6 Material data

| Gear pump | | | | |
|-----------|-------------------|---------------------------|---|-------------------------|
| Seal type | Material | | | |
| | O-ring | Housing/End cover | Gears | Bearing |
| 61 | FKM | EN-GJL-250 (GG-25) | Case-hardened steel (Steel 1.7139) | ETG 100 chem. nickel |
| 63 | FEP with FKM-core | | | |
| 65 | FKM | EN-GJS-400-15 (GGG-40) | chem. nickel with SiC deposits | with SiC deposits |

| Magnetic coupling | | | | | |
|-------------------------|---------------------|----------------------|-----------------------|----------------------------------|-----------------|
| Max. operating pressure | Material | | | | |
| | Internal rotor | External rotor | Containment shroud | Bell housing | Other materials |
| 150 °C (A) | 1.4571 / Sm2Co17 | Steel / NdFeB --- | 1.4571 --- | Al (mass fraction Mg ≤ 7.5 %) | Steel |
| 300 °C (B) | | Steel / Sm2Co17 | 1.4571 / Hastelloy | | |

4.7 Weight

| Nominal size V_{gn} | Gear pump [kg] | |
|--------------------------|----------------|----------------------------|
| | with end cover | with pressure relief valve |
| KF 1/4 | 3.0 | 3.8 |
| KF 1/8 | 3.7 | 4.5 |
| KF 1/11 | 3.8 | 4.6 |
| KF 1/16 | | |
| KF 1/20 | 4.1 | 4.9 |
| KF 1/24 | 4.2 | 5.0 |

| Magnetic coupling [kg] | | | | |
|---------------------------|-------|-------|-------|-------|
| MSA46 | MSA60 | MSB60 | MSB75 | MSC75 |
| 2.8 | 5.5 | 8.0 | 12.0 | 14.0 |

4.8 Dimensions

Dimensions of the device can be found in the relevant technical data sheets.

5 Transport and storage

5.1 General

- a) After receipt, check the device for transport damages.
- b) If transport damage is noticed, report this immediately to the manufacturer and the carrier. The device must then be replaced or repaired.
- c) Dispose of packing material and used parts in accordance with the local stipulations.

5.2 Transport



WARNING

Falling or overturning loads!

Danger of injury while transporting large and heavy loads.

- a) Use only suitable means of conveyance and lifting tackle with sufficient load-bearing capacity.
- b) Attach lifting tackle only to suitable load points.
- c) Attach the lifting tackle in such a manner that it cannot slip.
- d) Pay attention to the load balance point.
- e) Always avoid jerks, impacts and strong vibrations during transportation.
- f) Never walk under suspended loads, never work under suspended loads.



NOTICE

To transport the device , eyebolts can be screwed into the flange connections..

5.3 Storage

The device's function is tested in the plant with mineral hydraulic oil. Then all connections are closed. The remaining residual oil preserves the interior parts for up to 6 months.

Metallic exposed exterior parts are protected against corrosion by suitable conservation measures, also up to 6 months.

In case of storage, a dry, dust-free and low-vibration environment is to be ensured. The device is to be protected against influences from weather, moisture and strong fluctuations of temperature. The recommended storage conditions are to be adhered to.

Below the permissible ambient temperature ϑ_U elastomer seals lose their elasticity and mechanical loading capacity, since the glass transition temperature is fallen below. This procedure is reversible. A force action on the device is to be avoided in case of storage below the permissible ambient temperature ϑ_U .

Devices with EPDM seals are not mineral-oil resistant and are not tested for their function. There is no preservation of the interior parts. If the device is not taken into operation immediately, all corrosion-prone surfaces are to be protected by suitable conservation measures. The same applies for devices which are not tested for other reasons

When storing for a long period of time (> 6 months), treat all surfaces at risk of corrosion again with suitable preserving agents.

If high air humidity or aggressive atmospheres are expected, take additional corrosion-preventing measures.



NOTICE

Storage in corrosion protection bags (VCI) maximum of 6 months.

⚠ ATTENTION

Corrosion/chemical impact

Improper storage can render the device useless.

- a) Protect endangered surfaces by means of suitable conservation measures.
- b) Comply with recommended storage conditions.

5.4 Storage conditions



TIP

Recommended storage conditions

- a) Storage temperature: 5 °C – 25 °C
- b) Relative air humidity: < 70 %
- c) Protect elastomer parts from light, especially direct sunlight.
- d) Protect elastomer parts from oxygen and ozone.
- e) Comply with maximum storage times of elastomeric parts:
 - ⇒ 5 Years: AU (Polyurethane rubber)
 - ⇒ 7 Years: NBR, HNBR, CR
 - ⇒ 10 Years: EPM, EPDM, FEP/PFTE, FEPM, FKM, FFKM, VMQ, FVMQ

5.5 Special hazards



DANGER

Powerful magnetic field

Danger of death for people with heart pacemakers

- a) Maintain a safety clearance of at least 2 m to the unmounted components of the magnetic coupling.
- b) Maintain a safety clearance of at least 0.5 m to assembled couplings with axially aligned magnetic rotors and surrounding coupling housing (bell housing).



WARNING

Powerful magnetic field

Danger of injury due to uncontrolled mutual attraction of magnetic parts or parts that can be magnetized.

- a) When performing any work, bear in mind the magnetic forces which occur, especially within 0.5 m of the magnetic coupling.

ATTENTION

Powerful magnetic field

Magnetic data carriers (discs, credit cards, etc.) can be damaged or erased by magnetic fields.

- a) Maintain a minimum clearance of 1 m to the magnetic field.

6 Installation

6.1 Safety instructions for installation



DANGER

Hazardous fluids

Danger to life when handling hazardous fluids.

- a) Comply with the safety data sheets and regulations on handling the hazardous fluids.
- b) Collect and dispose of hazardous fluids so that no hazard is created for persons or the environment.



DANGER

Rotating parts!

Danger of death due to body parts, hair or clothing getting trapped or entangled.

- a) Before all work, ensure that existing drives are voltage-free and pressure-free.
- b) Securely prevent restarting during all work.



DANGER

Rotating parts

Danger of death due to body parts, hair or clothing getting trapped or entangled.

- a) Take measures against accidental touching of rotating parts.



WARNING

Rotating parts!

Danger of injury from flying parts.

- a) Enclose rotating parts so as to avoid any danger from flying parts in the event of breakage or malfunction.



WARNING

Unshielded gearwheels

Gearwheels can trap and crush fingers and hands.

- a) Do not engage gearwheels.

**⚠ WARNING****Failure of load-carrying parts due to overload!**

Danger of injury from flying parts.
Danger of injury from spurting fluids.

- a) Depressurise the device and all connection lines before doing any work.
- b) Securely prevent the restoration of pressure while working on the device.

**⚠ WARNING****Failure of pressure bearing parts due to overload**

Risk of injury from flying parts.
Risk of injury due to fluid spurting out.

- a) Use only connections and lines approved for the expected pressure range.
- b) Securely prevent the permissible pressures from being exceeded, e.g. by using pressure relief valves or bursting discs.
- c) Pipelines must be designed in such a way that no tension e.g. caused by changes in length due to fluctuations in temperature can be transferred to the product.

6.1.1 Special hazards



DANGER

Powerful magnetic field

Danger of death for people with heart pacemakers

- a) Maintain a safety clearance of at least 2 m to the unmounted components of the magnetic coupling.
- b) Maintain a safety clearance of at least 0.5 m to assembled couplings with axially aligned magnetic rotors and surrounding coupling housing (bell housing).



WARNING

Powerful magnetic field

Danger of injury due to uncontrolled mutual attraction of magnetic parts or parts that can be magnetized.

- a) When performing any work, bear in mind the magnetic forces which occur, especially within 0.5 m of the magnetic coupling.

ATTENTION

Powerful magnetic field

Magnetic data carriers (discs, credit cards, etc.) can be damaged or erased by magnetic fields.

- a) Maintain a minimum clearance of 1 m to the magnetic field.

6.2 Noise reduction



TIP

Measures for noise reduction

- a) Use suction and pressure hoses.
- b) Use bell housings with high damping properties (plastic or cast iron).
- c) Use of damping rings and damping rods for separation of structureborne noise.

6.3 Mechanical installation

6.3.1 Preparation

- a) Check the device for transport damage and dirt.
 - b) Check the device for freedom of movement.
 - c) Remove existing preservatives.
 - ⇒ Use only those cleaning agents that are compatible with the materials used in the device.
 - ⇒ Do not use cleaning wool.
 - d) Compare the environmental and ambient conditions at the place of installation to the permissible conditions.
 - ⇒ Ensure a sufficiently stable and level foundation.
 - ⇒ Expose the device only to small vibrations, see IEC 60034-14.
 - ⇒ Secure sufficient access for maintenance and repair.
 - e) Position the product and secure them against slipping.
 - ⇒ Comply with the manufacturer's information.
 - ⇒ Do not use any sealing materials such as hemp, Teflon tape or putty.
-

6.3.2 Gear pump for magnetic coupling

The prerequisite for trouble-free operation is suitable load transmission between the pump and the drive. By default, a permanent magnetic coupling is used for this.



TIP

For the assembly we recommend to have the data sheet of the magnetic coupling with you. Specifications entered in the dimensional drawing have to be primarily observed.



TIP

For assembly, the coupling halves can be heated to approx. 80 °C and pushed onto the shaft ends while warm.



CAUTION

Hot surfaces

Burn injury to skin if touched.

- a) Wear protective gloves at temperatures $\geq 48^{\circ}\text{C}$.
-



WARNING

Strong magnetic forces

Risk of crushing by suddenly engaging magnets.

- a) Pre-mount coupling parts as per manufacturer's specifications.
- b) Position the pumps and the drive with respect to each other.
 - ⇒ Comply with the permissible mounting position.
 - ⇒ Comply with the permissible direction of rotation.
- c) Tighten all fastening screws with the specified torque.

| Tightening torques [Nm] | | | | | | | |
|----------------------------------|-----|----|-----|-----|-----|-----|-----|
| Thread size | M6 | M8 | M10 | M12 | M16 | M20 | M24 |
| Counter-thread Aluminium | 4.6 | 11 | 22 | 39 | 95 | 184 | 315 |
| Counter-thread Cast iron / Steel | 10 | 25 | 49 | 85 | 210 | 425 | 730 |

⁽¹⁾ Screws/Nuts with min. strength class 8.8/8



TIP

- a) Keep to the permissible displacement values of the coupling.
- b) Rule out any distortion of the device.
- c) Pay attention to sufficient screw-in depth of the fastening screws.



NOTICE

- a) Make sure no foreign bodies can get into the device.

6.4 Connection lines

6.4.1 General



WARNING

Failure of load-carrying parts due to overload

Danger of injury from flying parts..
 Danger of injury from spurting fluids.

- a) Use only connections and lines approved for the expected pressure range.
- b) Securely prevent exceeding the permissible pressure, e.g. by using pressure relief valves or rupture discs.
- c) Design pipework so that no tensions, e.g. caused by changes in length due to fluctuations in temperature, are transmitted to the device.



NOTICE

Additional connections

- a) Provide measurement connections for pressure and temperature as close as possible to device.
- b) If necessary, provide a facility to fill or empty the device and the line system.
- c) If necessary, provide a facility to vent the device and the line system.

6.4.2 Suction line

A less than optimally planned suction line can lead to increased noise emission, cavitation as well as reduction of the delivery rate (caused by not complete filling of the pump).

When designing the line, take the following points into consideration:

The suction line must be piped as short as possible and in a straight line.

- Stipulate the nominal width of the suction line so that the permissible operating pressure $p_{e, \min}$ is not exceeded on the suction side.
- Avoid large suction heights.
- Avoid additional pressure loss through line resistances such as fittings, screwed connections, formed parts or suction filters/suction baskets. Ensure that all technically required suction filters/suction baskets are appropriately dimensioned.
- Make sure there is sufficient clearance of the suction port to the bottom and walls of the media container.
- Make sure that the suction opening lies underneath the lowest fluid level in all operating situations.
- When hose lines are used, ensure sufficient stability of the hoses so that they cannot become constricted through the sucking action.
- Comply with the recommended flow velocity in the suction line (max. 1.5 m/s).

Suction line at vacuum operation

If suction from a tank under vacuum is desired, the pump must be arranged approx. 1 m below the tank. The suction line must run in a straight line and without any resistances.

The tank may be subjected to vacuum only then when the pipe-work and the pump have been filled with liquid. For this application, only pumps suitable for vacuum operation may be used.

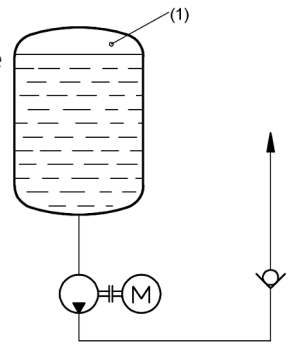

NOTICE

Cavitation damage

Undercutting the permissible suction port pressure results in cavitation.

- a) Design the suction line so that the pressure arising in operation on the suction side is always higher than the vapour pressure of the pumped medium. At the same time, comply with the installation altitude of the device above mean sea level.
- b) For aqueous fluids, mount the device underneath the fluid level, set the operating temperature to 50 °C and limit the speed to 1500 rpm.

Prevention of suction problems

If there is a possibility that the suction line can run dry if the pump stops, piping the suction line as siphon is an option to avoid suction problems. This way, the pump will remain permanently filled after initial commissioning.

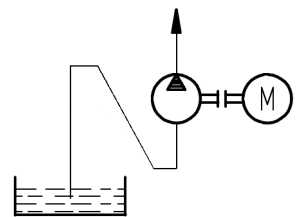

It is appropriate to employ a foot valve or a non-return valve in case of longer suction lines that can run dry while the pump is at rest. These must have been designed for use in suction lines and should offer as low a flow resistance as possible.

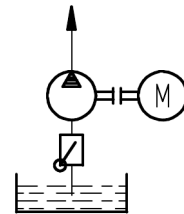

During operation of a pump that has to pump media via a non-return valve in a pressurized circuit (e.g. reserve pump in a lubricant circuit), suction problems can occur if the suction line is filled with air.

In this case the pressure pipe must be bled directly upstream of the non-return valve.

If no vent nozzle is used, the volume of the pressure pipe between the pump and the non-return valve must be at least 75 % of the suction line volume.

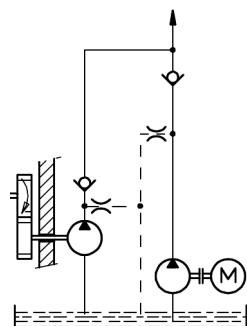

6.4.3 Pressure line

When designing the line, take the following points into consideration:

- Select the nominal width of the pressure line so that the maximum permissible pressures are not exceeded.
- If necessary, provide a vent nozzle to prevent suction problems.

6.4.4 Mounting Connection lines

- a) Clean all lines.
 - ⇒ Do not use cleaning wool.
 - ⇒ Pickle and flush welded pipes.
 - b) Remove the protective plugs.
 - c) Mount the lines.
 - ⇒ Comply with the manufacturer's information.
 - ⇒ Do not use any sealing materials such as hemp, Teflon tape or putty.
-



TIP

Position of the device connections: **Rotation and delivery direction** [▶ 18]

6.5 Change of the direction of rotation

Depending on the version a change in the direction of rotation is possible.

The manufacturer normally carries out the conversion work and the customer should do this only in exceptional cases.

7 Operation start-up

7.1 Safety instructions for start-up



DANGER

Hazardous fluids

Danger to life when handling hazardous fluids.

- a) Comply with the safety data sheets and regulations on handling the hazardous fluids.
- b) Collect and dispose of hazardous fluids so that no hazard is created for persons or the environment.



WARNING

Failure of load-carrying parts due to overload

Danger of injury from flying parts.

Danger of injury from spurting fluids.

- a) Do not operate the device against closed shut-off devices.
- b) Do not operate the device in the false direction of rotation.



CAUTION

Hot surfaces

Burn injury to skin if touched.

- a) Wear protective gloves at temperatures $\geq 48^{\circ}\text{C}$.

7.2 Special hazards



DANGER

Powerful magnetic field

Danger of death for people with heart pacemakers

- a) Maintain a safety clearance of at least 2 m to the unmounted components of the magnetic coupling.
- b) Maintain a safety clearance of at least 0.5 m to assembled couplings with axially aligned magnetic rotors and surrounding coupling housing (bell housing).



WARNING

Powerful magnetic field

Danger of injury due to uncontrolled mutual attraction of magnetic parts or parts that can be magnetized.

- a) When performing any work, bear in mind the magnetic forces which occur, especially within 0.5 m of the magnetic coupling.

ATTENTION

Powerful magnetic field

Magnetic data carriers (discs, credit cards, etc.) can be damaged or erased by magnetic fields.

- a) Maintain a minimum clearance of 1 m to the magnetic field.

7.3 Preparation

- a) Before starting the product, make sure that a sufficient quantity of the service fluid is extant to avoid dry running. This must be taken into account especially with large line volumes.
- b) Check all fastening screws on the product.
- c) Fill pump and the suction line with medium.

7.4 Pressure relief valve adjustment

The valves are factory set to the rated pressure of each pressure stage. Setting pressures that deviate from this are stated on the rating plate.

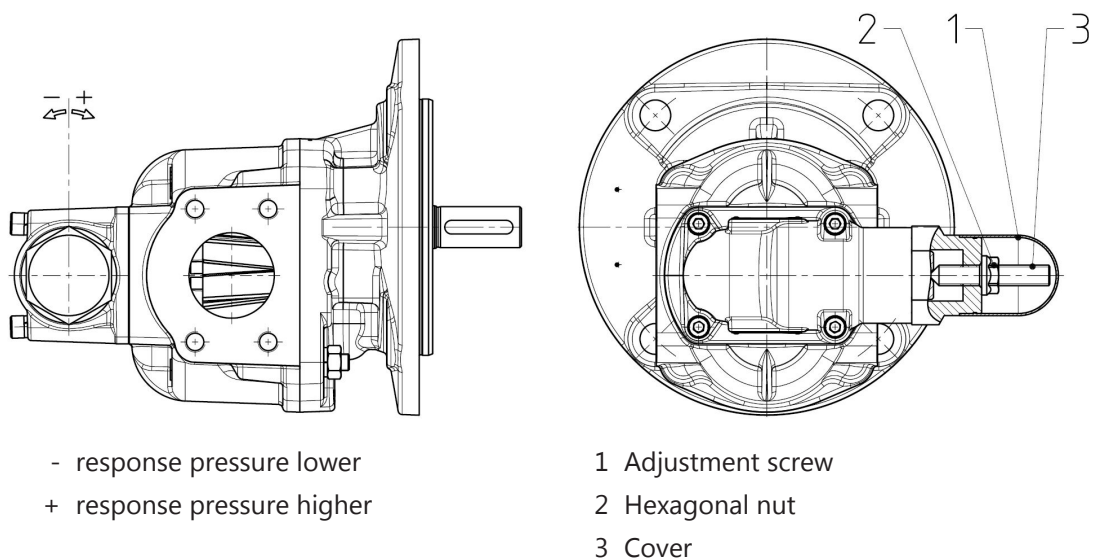

- a) Remove cover.
- b) Remove hexagonal nut.
- c) Set the response pressure using the adjusting screw.
- d) Secure the adjusting screw with hexagonal nut.
- e) Mount cover.



WARNING

Failure of load-carrying parts due to overload

Danger of injury from flying parts.
Danger of injury from spurting fluids.

- a) Consider the permissible pressure setting range of the valve.
- b) Check the pressure setting (the valve must not block).

7.4.1 Pressure relief valve

Directly attached pressure relief valves of the series "D" are used exclusively for protection of the gear pumps and may respond on a short-term basis only.



NOTICE

Failure of the pump

Long triggering of the valve can cause the pump to overheat.

- a) Only allow intermittent triggering of the valve.

7.5 Further operation start-up

- a) Open existing shut-off elements upstream and downstream of the device.
- b) Adjust pressure relief valves in the system installed for lowest opening pressure.
- c) Allow the device start without or with a low pressure load (jog mode).
 - ⇒ Flow should have developed after 30 s at the latest.
- d) Run the device for a few minutes depressurised or with low pressure.
- e) Vent the system at the highest possible point.
- f) Gradually increase the pressure load up to the desired operating pressure.
- g) Operate the system for so long until the final operating state is achieved.
- h) Check the operating data.
 - ⇒ **Maintenance table** [▶ 47]
- i) Document the operating data of the initial start-up for later comparison.
- j) Check the level of the operating medium in the system.
- k) Check the filling level of the liquid seal (if existing).
- l) Check the device for leaks.
- m) Check all threaded connections for leaks and retighten if necessary.



TIP

In order to ensure a constant and reliable function of the product, an initial maintenance of the product is recommended after several hours warm-up time (max. 24 h). This allows faults to be detected at an early stage.

8 Removal

8.1 Safety instructions for removal



⚠ DANGER

Hazardous fluids

Danger to life when handling hazardous fluids.

- a) Comply with the safety data sheets and regulations on handling the hazardous fluids.
- b) Collect and dispose of hazardous fluids so that no hazard is created for persons or the environment.



⚠ DANGER

Rotating parts!

Danger of death due to body parts, hair or clothing getting trapped or entangled.

- a) Before all work, ensure that existing drives are voltage-free and pressure-free.
- b) Securely prevent restarting during all work.



⚠ WARNING

Unshielded gearwheels

Gearwheels can trap and crush fingers and hands.

- a) Do not engage gearwheels.



⚠ WARNING

Failure of load-carrying parts due to overload!

Danger of injury from flying parts.

Danger of injury from spurting fluids.

- a) Depressurise the device and all connection lines before doing any work.
- b) Securely prevent the restoration of pressure while working on the device.



⚠ CAUTION

Hot surfaces

Burns of the skin on contact.

- a) At temperatures $\geq 48^{\circ}\text{C}$ the product must be allowed to cool down first.

⚠ ATTENTION**Blocking of the product due to curing media**

Curing media can mechanically block the product and make it unusable.

- a) Clean the product immediately after operation with curing media.

8.2 Special hazards

**⚠ DANGER****Powerful magnetic field**

Danger of death for people with heart pacemakers

- a) Maintain a safety clearance of at least 2 m to the unmounted components of the magnetic coupling.
- b) Maintain a safety clearance of at least 0.5 m to assembled couplings with axially aligned magnetic rotors and surrounding coupling housing (bell housing).

**⚠ WARNING****Powerful magnetic field**

Danger of injury due to uncontrolled mutual attraction of magnetic parts or parts that can be magnetized.

- a) When performing any work, bear in mind the magnetic forces which occur, especially within 0.5 m of the magnetic coupling.

⚠ ATTENTION**Powerful magnetic field**

Magnetic data carriers (discs, credit cards, etc.) can be damaged or erased by magnetic fields.

- a) Maintain a minimum clearance of 1 m to the magnetic field.

8.3 Removal

- a) Depressurise and de-energize the system.
 - b) Close existing shut-off elements upstream and downstream of the device.
 - c) Open existing drain elements and loosen connection lines. Collect and dispose of discharging medium so that no hazard arises for persons or environment.
 - d) Dismantle the device.
 - e) Clean the device
 - f) Close the device connections and lines to prevent dirt penetration.
-



NOTICE

The concrete procedure for cleaning depends on the media being used.

- a) See the safety data sheet of the media in use.
-

9 Maintenance

9.1 Important notes about explosion protection



⚠ DANGER

Hazardous fluids

Danger to life when handling hazardous fluids.

- a) Comply with the safety data sheets and regulations on handling the hazardous fluids.
- b) Collect and dispose of hazardous fluids so that no hazard is created for persons or the environment.



⚠ DANGER

Rotating parts!

Danger of death due to body parts, hair or clothing getting trapped or entangled.

- a) Before all work, ensure that existing drives are voltage-free and pressure-free.
- b) Securely prevent restarting during all work.



⚠ WARNING

Failure of load-carrying parts due to overload!

Danger of injury from flying parts.

Danger of injury from spurting fluids.

- a) Depressurise the device and all connection lines before doing any work.
- b) Securely prevent the restoration of pressure while working on the device.



⚠ CAUTION

Hot surfaces

Burns of the skin on contact.

- a) At temperatures $\geq 48^{\circ}\text{C}$ the product must be allowed to cool down first.

9.2 Special hazards



DANGER

Powerful magnetic field

Danger of death for people with heart pacemakers

- a) Maintain a safety clearance of at least 2 m to the unmounted components of the magnetic coupling.
- b) Maintain a safety clearance of at least 0.5 m to assembled couplings with axially aligned magnetic rotors and surrounding coupling housing (bell housing).



WARNING

Powerful magnetic field

Danger of injury due to uncontrolled mutual attraction of magnetic parts or parts that can be magnetized.

- a) When performing any work, bear in mind the magnetic forces which occur, especially within 0.5 m of the magnetic coupling.

ATTENTION

Powerful magnetic field

Magnetic data carriers (discs, credit cards, etc.) can be damaged or erased by magnetic fields.

- a) Maintain a minimum clearance of 1 m to the magnetic field.

9.3 Maintenance work



TIP

Checking and documentation of the operating data

Regular checking and documentation of all operating data helps to detect faults at an early stage.

- Perform maintenance according to specification.
- Replace defective and worn components.
- If required, request spare parts lists and assembly drawings from the manufacturer.
- Document the type and scope of the maintenance work along with the operating data.
- Compare the operating data with the values of the first commissioning. Determine the cause in case of major non-compliances (> 10 %).
- Dispose of packing material and used parts in accordance with the local stipulations.



NOTICE

Protective equipment and notices

After maintenance and/or repair, reattach all protective devices and notices removed in the process to their original position.

9.4 Maintenance instructions

The following information provides recommendations for maintenance work and maintenance intervals for the product in use.

Depending on the actual loads occurring during operation, the type, scope and interval of the maintenance work may deviate from the recommendations. A mandatory maintenance plan must be drawn up by the installer/operating company.



TIP

In the course of preventive maintenance, it is advisable to replace wearing parts before the wear limit is reached.

With the appropriate expertise and sufficient equipment, the repair can also be carried out by the installer/operating company.

If necessary, request spare parts lists and assembly drawings from the manufacturer.

Please consult the manufacturer for this purpose.



NOTICE

Warranty

Any warranty will be void if not executed properly.

9.5 Maintenance table

Maintenance table

| | | Firstly:after max. 24 h | Daily | 3000 Operating hours | 6000 Operating hours | As required | Additional information |
|--------|---|-------------------------|-------|----------------------|----------------------|-------------|------------------------|
| 9.5.1 | Inspection: Discharge flow | 2 | | | | | |
| 9.5.2 | Inspection: Operating pressure | 2 | | | | | |
| 9.5.3 | Inspection: Media temperature | 2 | | | | | |
| 9.5.5 | Inspection: Add-on valve function (if existing) | 2 | | | | | |
| 9.5.6 | Inspection: Check the potential compensation (if existing) | 2 | | | | | |
| 9.5.7 | Inspection: Condition of operating fluid | 2 | | | | | |
| 9.5.8 | Audiometric monitoring: Unusual noise | | 1 | | | | |
| 9.5.9 | Visual inspection: Leakages | | 1 | | | | |
| 9.5.10 | Visual inspection: Filling level of liquid seal (if existing) | | 2 | | | | |
| 9.5.1 | Inspection: Discharge flow | | | 2 | | | |
| 9.5.2 | Inspection: Operating pressure | | | 2 | | | |
| 9.5.3 | Inspection: Media temperature | | | 2 | | | |
| 9.5.4 | Inspection: Device temperature | | | 2 | | | |
| 9.5.5 | Inspection: Add-on valve function (if existing) | | | 2 | | | |
| 9.5.6 | Inspection: Check the potential compensation (if existing) | | | 2 | | | |
| 9.5.7 | Inspection: Condition of operating fluid | | | 2 | | | |
| 9.5.11 | Visual inspection: Condition gears | | | | 3 | | |
| 9.5.12 | Visual inspection: Condition of housing parts | | | | 3 | | |
| 9.5.13 | Visual inspection: Condition of plain bearings | | | | 3 | | |
| 9.5.14 | Visual inspection: Condition of shaft seal | | | | 3 | | |
| 9.5.15 | Replacing: Outboard bearings | | | | | 3 | |
| 9.5.17 | Replacing: Shaft seal | | | | | 3 | |
| 9.5.18 | Replacing: Other seals | | | | | 3 | |

1 - 0,1 h; 2 - 0,2 h; 3 - 0,75 h

9.5.1 Inspection: Discharge flow

The discharge flow is measured via the flow rate volume counters.

The values are displayed by the built-in controller in the electrical control system.

- If there is no discharge flow, check the individual components of the product.
- Comply with the product-specific data sheets/operating instructions.

9.5.2 Inspection: Operating pressure

The operating pressure is indicated by the pressure gauges

- If there is no operating pressure, check the individual components of the product
- Comply with the product-specific data sheets/operating instructions.

9.5.3 Inspection: Media temperature

The media temperature is measured through the temperature sensor.

The values are displayed by the built-in controller in the electrical control system.

- If the media temperature is too high or too low, check the product components.
- Comply with the product-specific data sheets/operating instructions.

9.5.4 Inspection: Device temperature

Measure the surface temperature in the area of the bearings.

9.5.5 Inspection: Add-on valve function (if existing)

Pressure relief valves must be actuated at regular intervals. This is the only way to ensure proper functioning.

9.5.6 Inspection: Check the potential compensation (if existing)

Check potential equalization for tight fit and function.

9.5.7 Inspection: Condition of operating fluid

Pay attention to colour (dark colouring), odour and milky turbidity.

- Replace operating fluid if necessary.

9.5.8 Audiometric monitoring: Unusual noise

In this case, attention must be paid to increased noise or uneven operation (pump unit).

- In case of unusual noises, check the individual components of the product, line attachments and the operating media for foam formation.
- Comply with the product-specific data sheets/operating instructions.

9.5.9 Visual inspection: Leakages

Care must be taken here to ensure that there is no leakage from the connections.

- In the event of leaks in the connections, the glands must be tightened and, if necessary, the seals replaced.

9.5.10 Visual inspection: Filling level of liquid seal (if existing)

Checking the confining fluid filling level is mandatory for safe pump operation. Top up the confining fluid as required.

If there is no automatic monitoring, the filling level must be checked at least before each shift begins.

If the filling level drops unusually fast within a short period of time, the outer but also the inner shaft seal could be leaking.

If the filling level should rise, the inner shaft seal may probably be leaking and the confining fluid is begin mixed with the pressurised medium.

- Stop plant operation immediately in both cases.

9.5.11 Visual inspection: Condition gears

Like shaft gear are wear items. In the event of excessive wear, the parts or the pump must be replaced.

Important control points are the mating surfaces of the shaft sealing ring and bearing bushes, the end faces of the shaft and pin wheels and the tooth flanks.

9.5.12 Visual inspection: Condition of housing parts

Like shaft gear are wear items. In the event of excessive wear, the parts or the pump must be replaced.

Important control points are the mating surfaces of the shaft sealing ring and bearing bushes, the end faces of the shaft and pin wheels and the tooth flanks.

9.5.13 Visual inspection: Condition of plain bearings

Like plain bearings are wear items. In the event of excessive wear, the parts or the pump must be replaced..

The wear limit of multi-layer plain bearings is reached when the bronze layer of the bearings is exposed to 50-70%.

The drive shaft and driven shaft are supported on the suction side under load in the bearings, so that the wear can be seen there first.

9.5.14 Visual inspection: Condition of shaft seal

Check on increased and impermissible temperature rises

- Small amounts of leakage, however, are indispensable for function.
- If there are excessive amounts of leakage, stop pump operation immediately.
Replace: Shaft seal.

9.5.15 Replacing: Outboard bearings

With corresponding expertise and sufficient equipment, the replacement can be carried out by the equipment builder/operator.

If required, request spare parts lists and assembly drawings from the manufacturer.

Use spare parts approved by the manufacturer only.

9.5.16 Replacing: Plain bearings (only by manufacturer)

The replacement is carried out only by the manufacturer.

Consult the manufacturer

9.5.17 Replacing: Shaft seal

With corresponding expertise and sufficient equipment, the replacement can be carried out by the equipment builder/operator.

If required, request spare parts lists and assembly drawings from the manufacturer.

Use spare parts approved by the manufacturer only.

9.5.18 Replacing: Other seals

With corresponding expertise and sufficient equipment, the replacement can be carried out by the equipment builder/operator.

If required, request spare parts lists and assembly drawings from the manufacturer.

Use spare parts approved by the manufacturer only.

10 Repairs

10.1 Safety instructions for repair



⚠ DANGER

Hazardous fluids

Danger to life when handling hazardous fluids.

- a) Comply with the safety data sheets and regulations on handling the hazardous fluids.
- b) Collect and dispose of hazardous fluids so that no hazard is created for persons or the environment.



⚠ DANGER

Rotating parts!

Danger of death due to body parts, hair or clothing getting trapped or entangled.

- a) Before all work, ensure that existing drives are voltage-free and pressure-free.
- b) Securely prevent restarting during all work.



⚠ WARNING

Failure of pressure bearing parts due to overload

Risk of injury from flying parts.

Risk of injury due to splashing fluids.

- a) Depressurize the system before all work.
- b) Securely prevent the pressure from being restored during work.



⚠ CAUTION

Hot surfaces

Burns of the skin on contact.

- a) At temperatures $\geq 48^{\circ}\text{C}$ the product must be allowed to cool down first.

10.2 Special hazards



DANGER

Powerful magnetic field

Danger of death for people with heart pacemakers

- a) Maintain a safety clearance of at least 2 m to the unmounted components of the magnetic coupling.
- b) Maintain a safety clearance of at least 0.5 m to assembled couplings with axially aligned magnetic rotors and surrounding coupling housing (bell housing).



WARNING

Powerful magnetic field

Danger of injury due to uncontrolled mutual attraction of magnetic parts or parts that can be magnetized.

- a) When performing any work, bear in mind the magnetic forces which occur, especially within 0.5 m of the magnetic coupling.

ATTENTION

Powerful magnetic field

Magnetic data carriers (discs, credit cards, etc.) can be damaged or erased by magnetic fields.

- a) Maintain a minimum clearance of 1 m to the magnetic field.

10.3 General

The repairs covers:

1. Troubleshooting
Determination of damage, pinpointing and localisation of the damage cause.
2. Elimination of damage
Elimination of the primary causes and replacement or repair of defective components.
The repair is generally made by the manufacturer.

Repairs by manufacturer

Before returning the device, fill in the return notification form. The form can be filled in on-line and is available as a pdf file download.



NOTICE

Device contains hazardous material

If the device was operated with dangerous liquids, it must be cleaned before the return. If this should not be possible, the safety data sheet of the hazardous material is to be provided beforehand.

Repair by equipment builder/operator

If corresponding expertise and sufficient equipment is available, the equipment builder/operator can also make the repairs. Please consult the manufacturer about this.

- a) If required, request spare parts lists and assembly drawings from the manufacturer.
- b) Use spare parts approved by the manufacturer only
- c) Dispose of packing material and used parts in accordance with the local stipulations.



NOTICE

Warranty

Any warranty will be void if not executed properly.



NOTICE

Protective equipment and notices

After maintenance and/or repair, reattach all protective devices and notices removed in the process to their original position.

10.4 Detecting and eliminating failures

| Fault | Potential causes | Possible measures |
|--|--|---|
| Increased noise | | |
| Pump cavitation | Excessive negative pressure (not complete filling of the pump) | Check suction line design Use noise-optimised pump |
| | Suction line clogged | Clean the suction line |
| | Suction filter plugged or too small | Clean suction filter or use a larger filter Replace filter element |
| | Suction basket plugged or too small | Clean intake strainer or dimension larger |
| | Fluid temperature too low | Adjust the temperature of medium |
| Foaming or air in media | Pump does not suck | Check the oil level in the tank |
| | | Check suction line |
| | | Check the shaft seal |
| | Shaft seal defective | Replace seals |
| | Suction connection leaking | Tighten or replace the screw connections |
| | | Replace seals |
| | System not vented | Vent the system |
| Return line ends above the fluid level | Extend return line | |
| Heavy foaming in the system, e.g. in gears | Use noise-optimised pump | |
| Mechanical vibrations | Incorrectly aligned and/or loose coupling | Correct the alignment of the coupling and secure the coupling halves |
| | Incorrectly and/or insufficient line fastening | Fixate lines with suitable fastening material (e.g. pipe clamps) |
| | Wobbling pressure relief valve | Increase valve opening pressure |
| | Not a noise-reducing setup | Use dampers |

| Pump does not suck | | |
|---------------------------------------|---|---|
| | Dry run | Fill pump and the suction line with medium |
| | Minimum filling level in the reservoir tank undercut | Refill media |
| | Wrong direction of rotation | Correct the direction of rotation |
| | Throttled/closed shut-off element in the suction line | Open the shut-off element |
| | Suction line clogged | Clean the suction line |
| | The air in the suction line cannot be compressed in the pressure line | Reduce the start-up pressure |
| | | Vent the pressure line |
| | | Increase volume of the pressure line |
| | Speed of the pump is too low | Check the pump design |
| | | During frequency inverter operation: Check the operation/line frequency |
| | Geodetic suction head too high | Check installation location |
| | | Provide pre-filling pump |
| Insufficient pressure | | |
| Insufficient pumping flow rate | | |
| | Excessive negative pressure (not complete filling of the pump) | Check suction line design |
| | Too high media viscosity | Provide pre-filling pump |
| | Speed of the pump is too low | Check the pump design |
| | | During frequency inverter operation: Check the operation/line frequency |
| | Throttled/closed shut-off element in the suction line | Open the shut-off element |
| | Suction line clogged | Clean the suction line |
| | Suction filter plugged or too small | Clean suction filter or use a larger filter |
| | | Replace filter element |
| | Suction basket plugged or too small | Clean intake strainer or dimension larger |
| | No response of a pressure relief valve | Increase valve opening pressure |
| | Pump does not suck | Check the oil level in the tank |
| | | Check suction line |
| | | Check the shaft seal |
| | Wear | Replace the device |

| Excessive operating temperature | | |
|--|---|--|
| | Cooling and heat dissipation insufficient | Increase the cooling capacity |
| | Not sufficient oil in the system | Check the container layout |
| | Excess fluid is being delivered into the supply tank via pressure relief valve under load | Check the pump design |
| Impermissible pump heating | | |
| | No response of a pressure relief valve | Increase valve opening pressure |
| | Pressure too high in association with a media viscosity that is too low | Check the system design |
| | Speed too fast in connection with media viscosity that is too high | Check the system design |
| | Gland lid overtightened (for gland seal) | Unscrew gland lid and readjust leakage |
| | Suction pressure too high | Reduce the pressure |
| | Wear | Replace the device |
| Leakage | | |
| Seal failure | Lack of maintenance | Comply with maintenance intervals Replace seals |
| | Mechanical damage | Replace seals |
| | Thermal overload | Check operating data Replace seals |
| | Pressure too high | Check operating data Replace seals |
| | Gas content in media too high | Check operating data Replace seals |
| | Corrosion/chemical degradation | Check material compatibility Replace seals |
| | Wrong direction of rotation | Correct the direction of rotation Replace seals |
| | Contaminated medium | Provide filtration Replace seals |
| | Gland lid not sufficiently tightened (for gland seal) | Retighten gland lid |
| | Loose screw connection | Tighten or replace the screw connections |

| Magnetic coupling | | |
|---|--|---|
| Change in operating noise and/or the occurrence of vibrations | Alignment error | See Operating/installation instructions for magnetic coupling: Failures, causes and clearance |
| | Breakdown of the magnetic forces | |
| Damaged exterior magnets due to assembly error (external rotor striking the containment shroud) | | |
| Repeated breakdown of the magnetic forces | Operating parameters do not match the coupling power | See Operating/installation instructions for magnetic coupling: Failures, causes and clearance |
| | Excessive operating temperature | |
| | Abrasive particles in the pumping medium that block the pump | |
| Pump does not suck The torque is not transmitted | The magnets of the interior and exterior rotors are not placed flush above one another | Check the assembly dimensions in accordance with the assembly drawing |
| Motor protection switch tripped | | |
| | Driving power too low | Check the drive design |
| | Motor incorrectly connected | Check motor connection |
| | Phase failure | Check feed/supply |
| | Current consumption too high | Check operating data |
| | | Check direction of rotation |
| Motor circuit breaker incorrectly designed | Check operating data | |
| Consult the manufacturer in the event of unidentifiable faults | | |