

KRACHT

D.0034620002

Operating instructions (Translation)

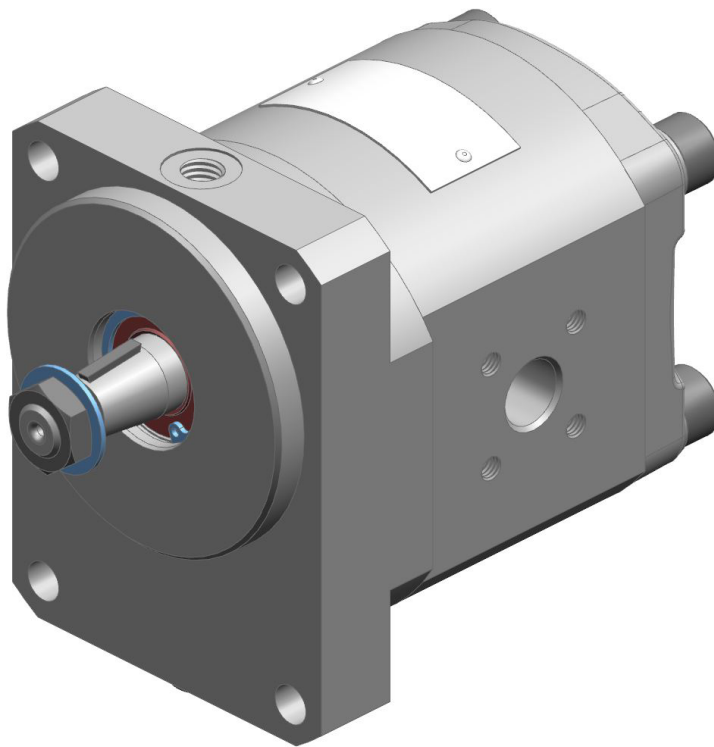

Gear pump KP 1 DuroTec®
English

Table of content

1 General	5
1.1 About the documentation	5
1.2 Manufacturer address	5
1.3 Other applicable documents	5
1.4 Symbols.....	6
2 Safety.....	7
2.1 Intended use.....	7
2.2 Personal qualification	7
2.3 Basic safety instructions	8
2.4 Fundamental hazards	8
3 Device description.....	10
3.1 Functional principle.....	10
3.2 Variants	11
3.3 Type key.....	12
3.4 Direction of rotation and discharge	13
3.5 Types of seals	13
3.6 Fluid seal.....	14
3.7 Special numbers	14
3.8 Shaft ends	15
4 Technical data.....	16
4.1 General.....	16
4.2 Nominal sizes.....	17
4.3 Assignment of viscosity - speed.....	17
4.4 Allowable pressures	18
4.4.1 Betriebsdruck Saugseite.....	18
4.5 Permissible temperature range	18
4.6 Material data.....	19
4.7 Weight.....	19
4.8 Dimensions.....	19
5 Transport and storage	20
5.1 General.....	20
5.2 Transport and shipping	20
5.3 Storage.....	20
5.4 Storage conditions	21

6	Installation	22
6.1	Safety instructions for installation	22
6.2	Noise reduction	23
6.3	Mechanical installation	24
6.3.1	Preparation.....	24
6.3.2	Gear pump with free shaft end	24
6.4	Connection lines.....	26
6.4.1	General.....	26
6.4.2	Suction line.....	26
6.4.3	Pressure pipe.....	28
6.4.4	Connection line installation.....	28
6.5	Change of the direction of rotation.....	28
6.5.1	Direction of supply	28
7	Commissioning	29
7.1	Safety instructions for start-up.....	29
7.2	Preparation	29
7.3	Filling the quench chamber	30
7.4	Additional commissioning.....	31
8	Removal.....	32
8.1	Safety instructions for disassembly.....	32
8.2	Dismantling	33
9	Maintenance	34
9.1	Safety instructions for maintenance	34
9.2	Maintenance work.....	35
9.3	Maintenance instructions.....	35
9.4	Maintenance table	36
9.4.1	Maintenance table.....	36
9.4.2	Check the rate of flow.....	37
9.4.3	Check the operating pressure.....	37
9.4.4	Check the media temperature.....	37
9.4.5	Check the device temperature	37
9.4.6	Check the function of the add-on valve	37
9.4.7	Check the equipotential bonding	37
9.4.8	Check the condition of the operating fluid.....	37
9.4.9	Auditory check Unusual noises	37
9.4.10	Cleaning	37
9.4.11	Visual inspection for leakage	38
9.4.12	Visual check of the gearbox condition.....	38
9.4.13	Visual check of the condition of housing parts	38
9.4.14	Visual check of the condition of the plain bearings	38
9.4.15	Visual check of the condition shaft seal	38
9.4.16	Visual check of the condition of the outboard bearing	38
9.4.17	Replacing the outboard bearing	38
9.4.18	Replacing the plain bearings.....	39
9.4.19	Replacing the shaft seal	39
9.4.20	Replacing other seals	39

10 Repair	40
10.1 Safety instructions for repairs	40
10.2 General	41
10.3 Fault table	42

1 General

1.1 About the documentation

These operating instructions describe the installation, operation and maintenance of the following product:

Gear pump KP 1 DuroTec®

These operating instructions are an integral part of the product and must be kept in the immediate vicinity of the

product and accessible to the personnel at all time.

Different versions of the product are produced. Which version is concerned is stated on the device's type plate.

If you have any questions about this operating manual, please contact the manufacturer.

1.2 Manufacturer address

KRACHT GmbH
Gewerbestraße 20
D-58791 Werdohl
Tel: +49 2392 935-0
Fax: +49 2392 935-209
Email: info@kracht.eu
Web: www.kracht.eu

1.3 Other applicable documents

In addition to these instructions, also comply with the relevant instructions of plants or plant parts available or planned on site.

1.4 Symbols



DANGER

Identification of an immediate hazard, which can lead to death or severe bodily injury if not avoided.



WARNING

Identification of a potential medium risk hazard, which can lead to death or severe bodily injury if not avoided.



CAUTION

Identification of a possible low-risk hazard that can result in minor or moderate physical injury if not avoided.

ATTENTION

Identification of notes to prevent property damage.



NOTICE

Identification of basic safety instructions. Non-compliance can lead to hazards for people and the product



TIP

Identification of special user tips and other particularly useful or important information

2 Safety

2.1 Intended use

1. The product has been designed for operation with fluids.
Dry operation is not permitted.
2. The product may only be operated when completely filled.
3. The fluid must be compatible with the materials used in the product. Chemical expertise is required for that. Be careful with ethylene oxide or other catalytically or exothermically reacting or self-decomposing substances. Please consult the manufacturer in cases of doubt.
4. The product may only be used in normal industrial atmospheres. If there are any aggressive substances in the air, always consult the manufacturer.
5. The product may only be operated in compliance with these operating instructions and the applicable documents.
Deviating operating conditions require the express approval of the manufacturer.
6. Use of the product for purposes other than those for which it is intended invalidates any warranty.

2.2 Personal qualification

The personnel charged with the assembly, operation and maintenance of the product must have the necessary qualifications.

This can be achieved through training or appropriate instruction.

The personnel must be familiar with the contents of these operating instructions.



NOTICE

Read the operating instructions in full before using the product.

2.3 Basic safety instructions



NOTICE

Basic safety instructions

Non-compliance can lead to hazards for people and the unit.

- a) Follow existing regulations for accident prevention and safety at work as well as the internal regulations of the operating company.
- b) Ensure the greatest possible cleanliness.
- c) Wear suitable personal protective equipment.
- d) Do not remove type plates or other information or make them illegible or unrecognisable.
- e) Do not make any technical modifications.
- f) Comply with maintenance intervals.
- g) Only use spare parts approved by the manufacturer.

2.4 Fundamental hazards



⚠ DANGER

Hazardous fluids

Danger to life when handling hazardous fluids

- a) Comply with the safety data sheets and regulations on handling the hazardous fluids.
- b) Collect and dispose of hazardous fluids so that no hazard is created for persons or the environment.



⚠ DANGER

Hazardous fluids

Danger to life when handling hazardous fluids.

- a) Defective components and connection lines must be replaced or fixed without delay.
- b) Use only components and connection lines approved for the expected pressure range.



⚠ DANGER

Rotating parts

Risk to life due to entanglement or winding of parts of the body, hair or clothing items.

- a) Before carrying out any work, disconnect any drives and actuators from the power supply or depressurise them.
- b) Safely prevent restarting during the work.

**⚠ DANGER****Rotating parts**

Risk to life due to entanglement or winding of parts of the body, hair or clothing items.

- a) Take measures to prevent accidental touching of rotating parts.

**⚠ WARNING****Rotating parts**

Risk of injury caused by ejected parts

- a) Enclose rotating parts so that in the event of fracture or malfunction, there is no risk caused by ejected parts.

**⚠ WARNING****Failure of pressure bearing parts due to overload**

Risk of injury from flying parts.

Risk of injury due to splashing fluids.

- a) Before carrying out any work, depressurise the product and all connection pipes.
- b) Securely prevent the pressure from being restored during work.

**⚠ WARNING****Failure of pressure bearing parts due to overload**

Risk of injury from flying parts.

Risk of injury due to splashing fluids.

- a) Use only connections and lines approved for the expected pressure range.
- b) Securely prevent the permissible pressures from being exceeded, e.g. by using pressure relief valves or bursting discs.
- c) Pipelines must be designed in such a way that no tension e.g. caused by changes in length due to fluctuations in temperature can be transferred to the product.

**⚠ WARNING****Failure of pressure bearing parts due to overload**

Risk of injury caused by flying parts.

Risk of injury caused by splashing fluids.

- a) Do not operate the product with shut-off devices closed.
- b) Do not operate the production in the wrong rotational direction.

3 Device description

3.1 Functional principle

The pumps of this series are external gear pumps, which operate according to the displacement principle.

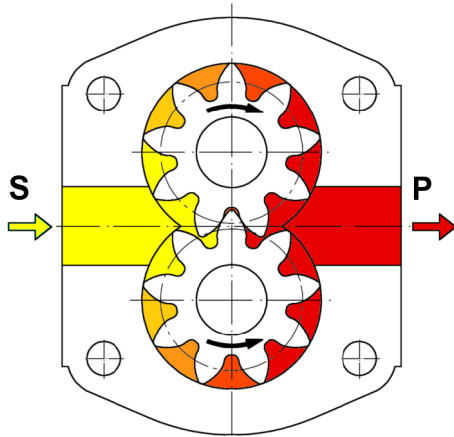

S Suction connection
P Pressure connection

During rotation, two interlocking gears cause a volume increase by opening the tooth spaces on the suction side (S), so that the medium can flow in and at the same time, on the discharge side (pressure side, P), a corresponding volume is displaced by the meshing of the teeth in the filled tooth gaps. Fluid transport takes place through entrainment in the tooth spaces along the wall of the wheel chamber.

With each gear rotation, the so-called geometric displacement volume V_g is displaced.

A value that is named the rated volume V_{gn} in technical documents to specify the pump size.

The displacement process described takes place initially without a noticeable pressure build-up. Only after external loads are applied, e.g. by head, flow resistances, pipe elements, etc., does the required working pressure set in to overcome these resistances.

The pressure applied to the shaft seal equals the pressure at the suction connection of the product. The permissible pressure is determined by the type of seal.

3.2 Variants

Gear pump

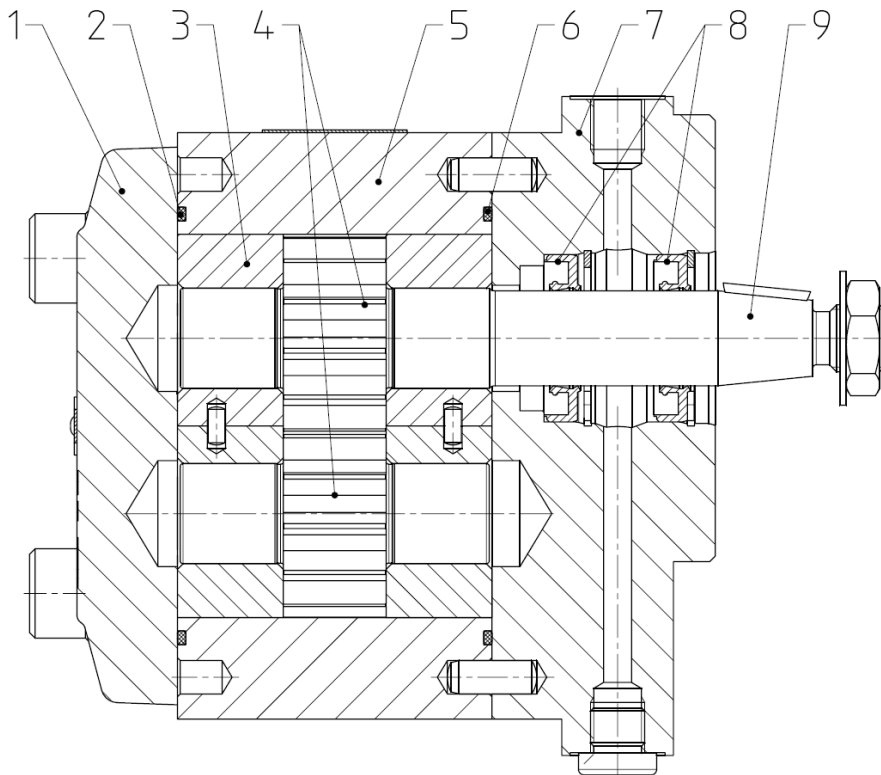

- | | | | |
|---|--------------------|---|------------|
| 1 | End cover | 2 | O-ring |
| 3 | Bearing bush | 4 | Gears |
| 5 | Housing | 6 | O-ring |
| 7 | Flange cover | 8 | Shaft seal |
| 9 | End of drive shaft | | |

3.3 Type key

Ordering example																		
KP		1/	8		G	1	0	A		K	0	A		4	V	L	2	/ ...
1.		2.	3.		4.	5.	6.	7.		8.	9.	10.		11.	12.	13.	14.	15.

Explanation of type key			
1. Product name			
2. Size			
1			
3. Nominal			
V_{gn}	3; 5,5; 6,3; 8; 11; 16; 22		
4. Fixing type			
G	Rectangular 4-hole flange		
5. Direction of rotation			
1	Clockwise	2	Counterclockwise
6. Outboard flange / Roller bearings			
0	Without		
7. Construction of housing			
A	Bolt circle	G	Whitworth pipe thread
B	Whitworth pipe thread	U	Bolt circle
8. Shaft end			
K	Cone 1:5 ($M_{max} = 160 \text{ Nm}$)	X	Gear shaft profile ($M_{max} = 70 \text{ Nm}$)
9. 2nd shaft end			
0	Without		
10. End cover			
A	End cover		
11. Design serial number (specified by manufacturer)			
12. Housing material and plain bearing			
V	Housing material: EN-GJS-600 Bearing bush : SSiC	V with Special number 492	Housing material: Stainless steel (1.4404) Bearing bush : SSiC
13. Gears version			
L	Tool steel (1.2379)	L with Special number 492	Stainless steel (1.4462)
14. Sealing material			
2	FKM	72	FKM
32	PTFE / FEP with FKM-core	85	EPDM / FKM
33	EPDM		
15. Special number			
Special numbers [▶ 14]			

3.4 Direction of rotation and discharge

The direction of rotation is indicated by the curved arrow, when looking towards the end of the drive shaft. The pump connections are below the drive shaft.

The flow direction is indicated by the straight arrow.

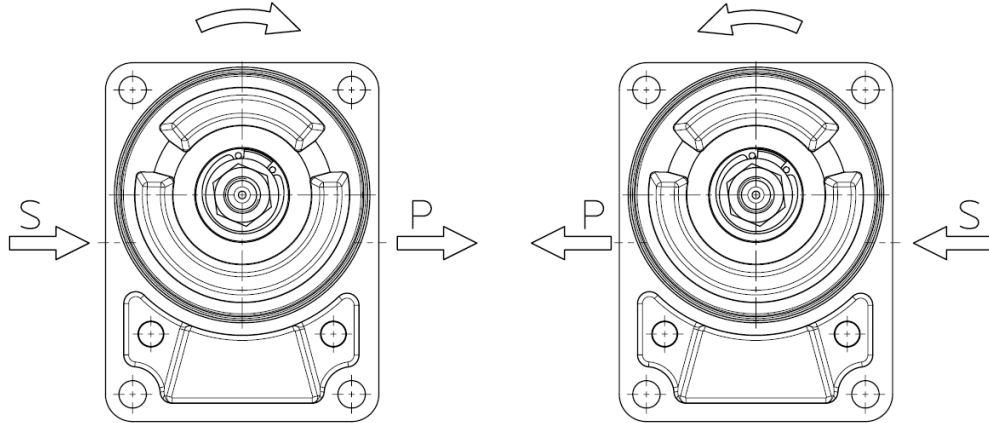

S = Suction connection
 P = Pressure connection

3.5 Types of seals

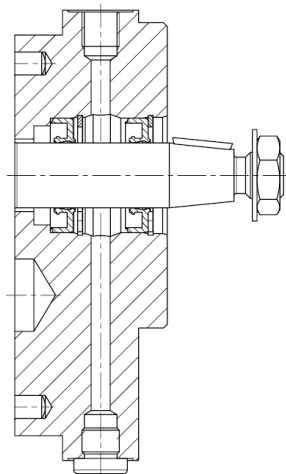

Double rotary shaft seal
 Connection borehole G 1/8
 (for fluid buffer)
 Sealing material: 2; 32; 33
 Special number: 245; 437; 439; 486

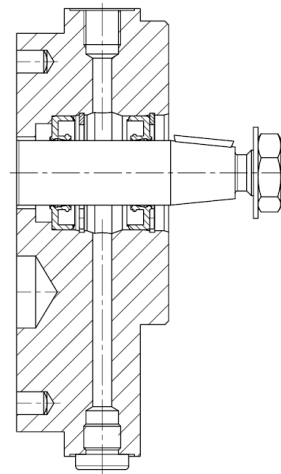

Double rotary shaft seal
 (for vacuum operation)
 Connection borehole G 1/8
 (for fluid buffer)
 Sealing material: 2
 Special number: 297; 492

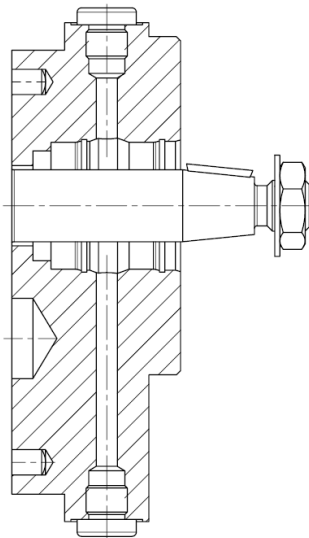

Without shaft seal
 (Leak oil drain through
 shaft sealing chamber)
 Sealing material: 72
 Special number: 245

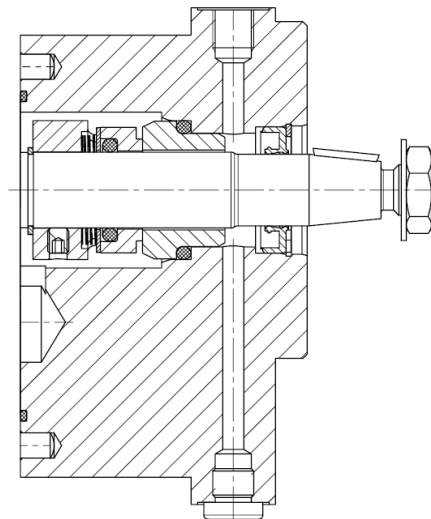

Mechanical seal with fluid buffer
 Connection borehole G 1/8
 (for fluid buffer)
 Sealing material: 2; 85
 Special number: 380; 522

3.6 Fluid seal

Versions with a fluid seal are used if absolute leak tightness is required at the shaft seal, e.g. when pumping media

- which harden on contact with air.
- which crystallise on contact with the moisture in air.
- which must not be allowed to leak into the environment.
- which are under vacuum and whose seal should be gas tight.

Select the installation so that the connection for the fluid seal is at the top.

3.7 Special numbers

Special number	Description
245	DuroTec® Basic version
297	Flange and end cover stainless steel PVD coated
380	Mechanical seal with fluid buffer
437	With axial clearance compensation
439	With axial clearance compensation, Steel plain bearing
486	DuroTec® Follow plate pump
492	Stainless steel version, nickel-phosphorus-coated gear unit
522	Follow plate pump with mechanical seal

3.8 Shaft ends

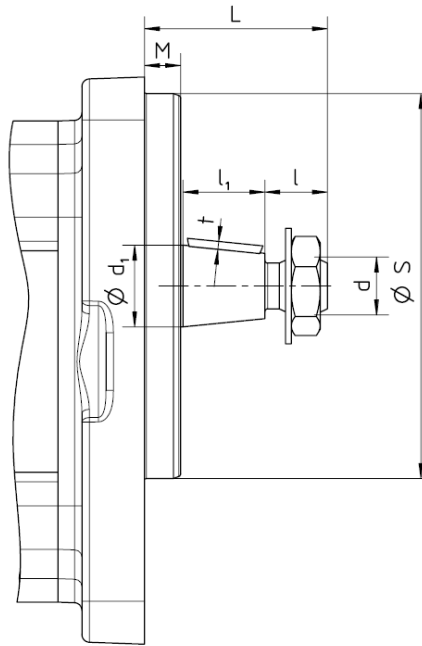

Shaft end	L	S	M	Cone	d	d ₁	l	l ₁	t
K	38	80	7.5	1:5	M12x1.5	17	13	17	1.5

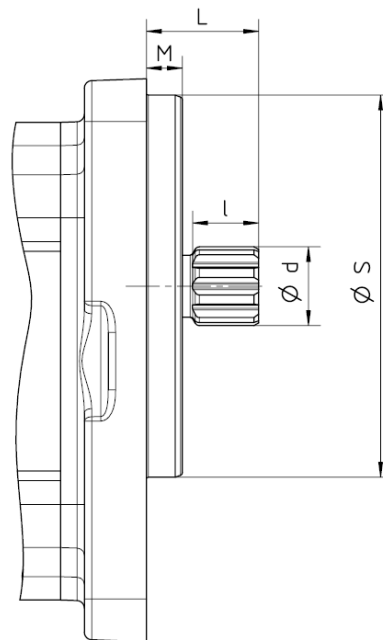

Shaft end	L	S	M	Profile	DIN	Number of teeth	d _{h11}	l
X	26	80	7.5	B17x14	5482	9	16.5	14

4 Technical data

4.1 General

General information				
Housing connection	A	KP 1/3	Suction connection: Ø15/LK40	Pressure connection: Ø15/LK35
		KP 1/5.5 – KP 1/22	Suction connection: Ø20/LK40	
	B	Suction connection: Whitworth pipe thread: G1		Pressure connection: Whitworth pipe thread: G3/4
		Suction connection: Whitworth pipe thread: G3/4		Pressure connection: Whitworth pipe thread: G1/2
	U	Suction connection: Ø25 Im End cover	Pressure connection: Ø15/LK35	
Fixing type	G	LA= 72/100; ØZ= 80		
LK= Bolt circle; LA= Hole distance; Z= Centering diameter;				
Mounting position	Shaft end horizontal , fluid buffer connection top			
Speed	n	Assignment of viscosity - speed [▶ 17]		
Operating pressure	p_e	Betriebsdruck Saugseite [▶ 18]		
	p_b	Assignment of viscosity - speed [▶ 17]		
Viscosity	v_{min}	30 mm ² /s		
	v_{max}	20 000 mm ² /s		
Fluid temperature	ϑ_m	Permissible temperature range [▶ 18]		
	ϑ_u			
Mechanical efficiency	η	Vol. Mechanical efficiency 85% at 100 bar, n= 1000 1/min with test medium HLP 46 at 20°C		
Materials	Material data [▶ 19]			
Permissible media	Version Ductil cast iron	Lubricating fluids with abrasive components Polyols; Silicates (water glass); Isocyanates ; Mineral oil		
	Version Stainless steel	Liquids compatible with stainless steel		

4.2 Nominal sizes

Nominal	Geom. displacement	Mass inertia
V_{gn}	V_g	$\times 10^{-6}$
	[cm ³ /rev.]	J [kg m ²]
3	3	23.3
5.5	5.45	35.7
6.3	6.28	39.9
8	7.9	51.1
11	10.9	62.9
16	15.9	87.7
22	22.3	119.6

4.3 Assignment of viscosity - speed

KP 1 - Ductil cast iron					
Kinematic viscosity	Speed n [rpm]		Pressure p [bar]		Viscosity surcharge
ν [mm ² /s]	$n_{min.}$	$n_{max.}$	p at $n_{min.}$	p at $n_{max.}$	[kW / l/min]
30	300	1500	50	100	-
100	200			120	
300	100	1100	150	150	0.003
1000					0.009
3000					0.017
6000					0.023
10000					0.027
20000					0.034

KP 1 - Stainless steel					
Kinematic viscosity	Speed n [rpm]		Pressure p [bar]		Viscosity surcharge
ν [mm ² /s]	$n_{min.}$	$n_{max.}$	p at $n_{min.}$	p at $n_{max.}$	[kW / l/min]
30	500	1500	20	40	-
100	250		30	80	
300			60	120	0.003
1000	150	1100	80	120	0.009
3000	100	750			0.017
6000		600			0.023
10000		500			0.027
20000		350			0.034



TIP

Select the speed of rotation so that complete filling of the pump is ensured. This is the case if the pressure on the suction side does not fall below the permissible pressure $p_{e\ min}$.

4.4 Allowable pressures

4.4.1 Betriebsdruck Saugseite

Sealing material	Seal type	Special number	Operating pressure	
			Suction side	
			$P_{e \text{ min.}}$ [bar _{abs.}]	$P_{e \text{ max.}}$ [bar _{rel.}]
FKM	Double rotary shaft seal (BABSL)	245	-0.4	4.0 (1500 1/min) 5.0 (1000 1/min) 10.0 (500 1min)
		437		
		439		
		486		
	Double rotary shaft seal for vacuum operation (BABSL)	297	-0.4	16.0
		492		
Mechanical seal with FKM secondary seals Q10Q10VG1G1	380	-0.4	16.0	
	522			
PTFE / FEP with FKM-core	Double rotary shaft seal (HN2390)	245	-0.4	2
EPDM		245		0.5
FKM	Without shaft seal	245	Assignment of viscosity - speed [► 17]	
EPDM / FKM	Mechanical seal with EPDM secondary seals Q10Q10EG1G1	380	-0.4	16.0

4.5 Permissible temperature range

Fluid temperature ϑ_m	
$\vartheta_{m \text{ max}}$ [°C]	
150	
100 (Special number 439)	
Ambient temperature ϑ_u	
$\vartheta_{u \text{ min}}$ [°C]	$\vartheta_{u \text{ min}}$ [°C]
-20	60



NOTICE

Note media-specific properties.

4.6 Material data

Special number	Materials					
	Housing	Flange cover / End cover	Gears	Bearing bush	Shaft seal	O-ring
245	EN-GJS-600	EN-GJS-400-15	Tool steel 1.2379 hardened, CVD-coated	SSiC	FKM, PTFE, EPDM	FKM, FEP with FKM-core, EPDM - peroxide cured
437				Steel (St) nitrided		
486						
439		Stainless steel (1.4404), PVD-coated		SSiC	Q10Q10VG 1G1	FKM
297						
380						
522		EN-GJS-400-15		Q10Q10EG 1G1 Rotary shaft seal: FKM	EPDM - peroxide cured	
380 with Sealing material 85						
492	Stainless steel (1.4404)	Stainless steel (1.4404)	Stainless steel (1.4462), nickelphosphor coated	FKM	FKM	

4.7 Weight

Nominal	Weight
V_{gn}	[kg]
3	4,1
5,5	4,3
6,3	4,4
8	4,5
11	4,8
16	5,3
22	5,7

4.8 Dimensions

The dimensions of the product are given in the technical data sheets.

5 Transport and storage

5.1 General

- a) After receiving the delivery, check the product for transport damage.
- b) If transport damage is found, the manufacturer and the transport company must be notified immediately. The product must then be replaced or repaired.
- c) Dispose of packaging materials and used parts according to local regulations.

5.2 Transport and shipping



WARNING

Falling or toppling loads

Risk of injury during transport of large and heavy loads.

- a) Use only suitable means of transport and lifting gear with sufficient load-bearing capacity.
- b) Attach lifting gear only to suitable places on the load.
- c) Attach the lifting gear so that it cannot slip.
- d) Note the centre of gravity of the load.
- e) Avoid sudden, jerky movements, impacts and strong vibrations during transport.
- f) Do not step under overhead loads, do not work under overhead loads.



NOTICE

Eyebolts can be screwed into the thread of the flanged connections to transport the product.

5.3 Storage

The product's function is tested in the factory with mineral hydraulic oil. The connections are then closed. The remaining residual oil preserves the internal parts for up to 6 months.

Bright metallic external parts are also protected against corrosion by suitable preservation measures for up to 6 months.

During storage, ensure a dry, dust-free and low-vibration environment. The product must be protected from weather, moisture and large temperature fluctuations. Comply with the recommended storage conditions.

Below the permissible ambient temperature ϑ_U , elastomer seals lose their elasticity and mechanical loading capacity, as the temperature is below the glass transition temperature. This process is reversible. Avoid the application of force on the product during storage below the permissible ambient temperature ϑ_U .

Products with EPDM seals are not mineral oil resistant and their function is not tested. The internal parts are not preserved. If the product is not put into operation immediately, all surfaces exposed to corrosion must be protected by suitable preservation measures. The same applies to products that are not tested for other reasons.

In case of storage for a longer period (> 6 months), all surfaces exposed to corrosion must be retreated with suitable preservatives.

If high humidity or an aggressive atmosphere is to be expected, additional suitable corrosion prevention measures must be taken.



NOTICE

Storage in corrosion protection bags (VCI) for maximum 6 months.

⚠ ATTENTION

Corrosion/chemical attack

Improper storage can make the product unusable.

- a) Use suitable preservation measures to protect exposed surfaces.
- b) Comply with the recommended storage conditions.

5.4 Storage conditions



TIP

Recommended storage conditions

- a) Storage temperature: 5 °C – 25 °C
- b) Relative humidity: < 70 %
- c) Protect elastomer parts from light, particularly direct sunlight.
- d) Protect elastomer parts from oxygen and ozone.
- e) Note the maximum storage period of elastomer parts:
 - ⇒ 5 years: AU (polyurethane rubber)
 - ⇒ 7 years: NBR, HNBR, CR
 - ⇒ 10 years: EPM, EPDM, FEP/PFTE, FEPM, FKM, FFKM, VMQ, FVMQ

6 Installation

6.1 Safety instructions for installation



⚠ DANGER

Hazardous fluids

Danger to life when handling hazardous fluids

- a) Comply with the safety data sheets and regulations on handling the hazardous fluids.
- b) Collect and dispose of hazardous fluids so that no hazard is created for persons or the environment.



⚠ DANGER

Rotating parts

Risk to life due to entanglement or winding of parts of the body, hair or clothing items.

- a) Before carrying out any work, disconnect any drives and actuators from the power supply or depressurise them.
- b) Safely prevent restarting during the work.



⚠ DANGER

Rotating parts

Risk to life due to entanglement or winding of parts of the body, hair or clothing items.

- a) Take measures to prevent accidental touching of rotating parts.



⚠ WARNING

Rotating parts

Risk of injury caused by ejected parts

- a) Enclose rotating parts so that in the event of fracture or malfunction, there is no risk caused by ejected parts.



⚠ WARNING

Exposed gears

Gearwheels can trap and crush fingers and hands.

- a) Do not engage gearwheels.

**⚠ WARNING****Failure of pressure bearing parts due to overload**

Risk of injury from flying parts.

Risk of injury due to splashing fluids.

- a) Before carrying out any work, depressurise the product and all connection pipes.
- b) Securely prevent the pressure from being restored during work.

**⚠ WARNING****Failure of pressure bearing parts due to overload**

Risk of injury from flying parts.

Risk of injury due to splashing fluids.

- a) Use only connections and lines approved for the expected pressure range.
- b) Securely prevent the permissible pressures from being exceeded, e.g. by using pressure relief valves or bursting discs.
- c) Pipelines must be designed in such a way that no tension e.g. caused by changes in length due to fluctuations in temperature can be transferred to the product.

6.2 Noise reduction

**TIP****Measures to reduce noise**

- a) Use of suction and pressure hoses.
- b) Use of pump supports with high damping properties (plastic or grey cast iron)
- c) Use of damping rings and damping rails to isolate structure-borne sound.

6.3 Mechanical installation

6.3.1 Preparation

-
- a) Check the product for transport damage and contamination.
 - b) Check the product for smooth and easy movement.
 - c) Remove any preservative present.
 - d) Clean all lines.
 - ⇒ Only use cleaning agents that are compatible with the materials used.
 - ⇒ Do not use cleaning wool.
 - e) Compare the environmental and ambient conditions at the place of use with the permissible conditions.
 - ⇒ Make sure that the foundation is sufficiently stable and level.
 - ⇒ Expose the product only to low vibrations, see IEC 60034-14.
 - ⇒ Ensure sufficient accessibility for maintenance and repair.
 - f) Position the product and secure it against slipping.
 - ⇒ Comply with the manufacturer's instructions.
 - ⇒ Do not use any sealing materials such as hemp, Teflon tape or putty.
 - g) Remove existing protective plugs.
-

6.3.2 Gear pump with free shaft end

Suitable power transmission between the gear pump and drive is required for fault-free operation.

In a standard product, a flexible claw coupling is used for this.

-
- a) Preassemble the coupling parts as described by the manufacturer.
 - b) Position the pump and drive relative to each other.
 - ⇒ Note the allowable installed position.
 - ⇒ Note the allowable direction of rotation.
 - c) Tighten the fastening screws to the specified torque.
-



⚠ DANGER

Rotating parts

Risk to life due to entanglement or winding of parts of the body, hair or clothing items.

- a) Take measures to prevent accidental touching of rotating parts.
-



⚠ CAUTION

Hot surfaces

Burns of the skin on contact.

- a) Wear protective gloves at temperatures $\geq 48^{\circ}\text{C}$.

Tightening torques [Nm]							
Thread size	M6	M8	M10	M12	M16	M20	M24
Counter-thread Aluminium	4.6	11	22	39	95	184	315
Counter-thread Cast iron / Steel	10	25	49	85	210	425	730

Screws/Nuts with min. strength class 8.8/8



NOTICE

- a) Comply with the allowable displacement values of the coupling.
- b) Prevent stressing of the product.
- c) Make sure the fastening screws have sufficient depth of engagement.



NOTICE

- a) In case of products without a shaft seal, make sure that the leaked oil from the shaft seal space is removed in a controlled way and does not get into the environment.
- b) Make sure that foreign objects cannot get into the product.
- c) If products have a fluid seal, install a tank for holding the seal fluid.
 - ⇒ Install the tank above the product.
 - ⇒ The connection on the device must face upwards.
 - ⇒ It must be possible to check the fluid level at any time.

6.4 Connection lines

6.4.1 General



WARNING

Failure of pressure bearing parts due to overload

Risk of injury from flying parts.

Risk of injury due to splashing fluids.

- a) Use only connections and lines approved for the expected pressure range.
- b) Securely prevent the permissible pressures from being exceeded, e.g. by using pressure relief valves or bursting discs.
- c) Pipelines must be designed in such a way that no tension e.g. caused by changes in length due to fluctuations in temperature can be transferred to the product.



NOTICE

Additional connections

- a) Provide measurement connections for pressure and temperature as near as possible on the device.
- b) If necessary, provide an option for filling and draining the device and line system.
- c) If necessary, provide an option for venting the device and line system.

6.4.2 Suction line

A suction line that is not optimally designed can lead to increased noise emissions, cavitation and even a reduction in the capacity (due to less filling of the pump).

When designing the lines, bear in mind the following points:

- Lay the suction line as short and straight as possible.
- Specify the nominal size of the suction line so that the operating pressure on the suction side is not less than the permissible operating pressure $p_{e \text{ min}}$.
- Avoid large suction heights.
- Avoid additional pressure loss through line resistances such as fittings, screwed connections, formed parts or suction filters/suction baskets. Ensure that all technically required suction filters/suction baskets are appropriately dimensioned.
- Pay attention to sufficient distance of the suction opening from the floor and walls of the media tank.
- Make sure that the suction opening is below the lowest fluid level in any operating situation.
- When using hoses, make sure that they have sufficient stability so that they do not become constricted by the suction effect.
- Note the recommended flow velocity in the suction line (max. 1.5 m/s).

Suction line at vacuum operation

If medium is to be drawn from a tank under vacuum, the pump must be positioned approx. 1 m below the tank. The suction line must be laid straight and without any resistances.

The tank may be subjected to vacuum only then when the pipework and the pump have been filled with liquid. Only pumps suitable for vacuum operation may be used for this purpose.

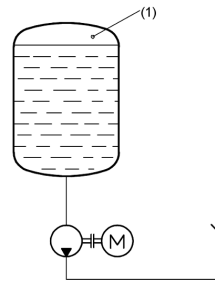

NOTICE

Cavitation damage

Pressure below the permissible suction side pressure causes cavitation

- a) Design the suction line so that the pressure that sets in during operation is always higher on the suction side than the vapour pressure of the pumped medium. At the same time, make sure that the device is installed above sea level.
- b) If fluids contain water, install the device below the fluid level and limit the operating temperature to 50 °C and the speed to 1500 1/min.

Prevention of suction problems

If there is a possibility of the suction line running dry while the pump is at a standstill, laying the suction line as a U-trap is a way of avoiding suction problems. This way, the pump will remain permanently filled after initial commissioning.

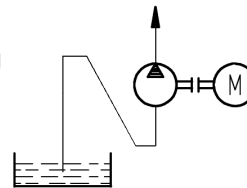

In case of longer suction lines that can run empty during the standstill, it is useful to insert a foot valve or a non-return valve. These must have been designed for use in suction lines and should offer as low a flow resistance as possible.

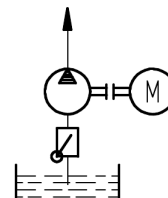

When operating a pump that has to pump via a non-return valve into a pressurized circuit (e.g. reserve pump in a lubricant circuit), intake difficulties can occur if the suction line is filled with air. In this case the pressure line must be vented directly upstream of the non-return valve. If a venting nozzle is not inserted, the volume of the pressure line between the pump and non-return valve must be at least 75% of the suction line volume.

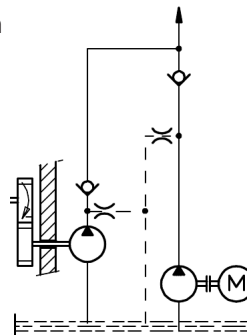

6.4.3 Pressure pipe

When designing the lines, bear in mind the following points:

- Choose the nominal size of the pressure line so that the maximum permissible pressures are not exceeded.
- If necessary, provide a venting nozzle to prevent suction problems.

6.4.4 Connection line installation

- a) Clean all lines.
 - ⇒ Do not use cleaning wool.
 - ⇒ Pickle and rinse welded pipes.
- b) Remove existing protective plugs.
- c) Install the lines.
 - ⇒ Comply with the manufacturer's instructions.
 - ⇒ Do not use any sealing materials such as hemp, Teflon tape or putty.



TIP

Location of the device connections: Direction of rotation and discharge

6.5 Change of the direction of rotation

A change in the direction of rotation is not possible.

6.5.1 Direction of supply

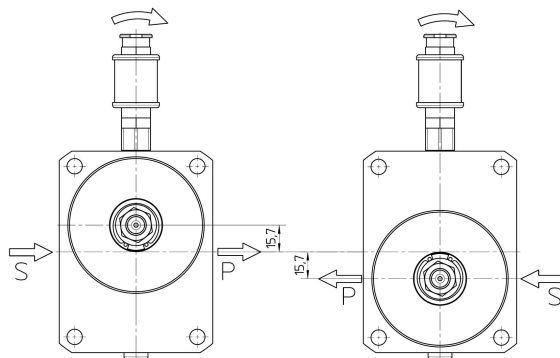

- S = Suction connection
P = Pressure connection

Change the direction of supply while the direction of rotation remains the same by turning the pump by 180°.

7 Commissioning

7.1 Safety instructions for start-up



⚠ DANGER

Hazardous fluids

Danger to life when handling hazardous fluids

- a) Comply with the safety data sheets and regulations on handling the hazardous fluids.
- b) Collect and dispose of hazardous fluids so that no hazard is created for persons or the environment.



⚠ WARNING

Failure of pressure bearing parts due to overload

Risk of injury caused by flying parts.

Risk of injury caused by splashing fluids.

- a) Do not operate the product with shut-off devices closed.
- b) Do not operate the production in the wrong rotational direction.



⚠ CAUTION

Hot surfaces

Burns of the skin on contact.

- a) Wear protective gloves at temperatures $\geq 48^{\circ}\text{C}$.

7.2 Preparation

- a) Before starting the system make sure that a sufficient quantity of the service fluid is extant to avoid dry running. This must be taken into account especially with large line volumes.
- b) Check all fastening screws on the product.
- c) Fill the pump and the suction line with medium.

7.3 Filling the quench chamber

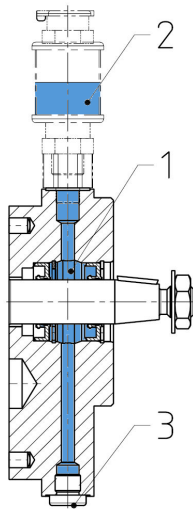

- | | | | |
|---|-----------------------------|---|---------------|
| 1 | Quench chamber | 3 | Venting screw |
| 2 | Container for quench-liquid | | |

-
- a) For versions with fluid seal, fill the quench chamber with a suitable seal fluid.
- ⇒ Fill from the tank provided.
 - ⇒ Fill fluid until the quench chamber is completely full and the tank is half full.
- b) Do not apply pressure or vacuum to the quench chamber.
-



NOTICE

Seal failure due to running dry

Lack of seal fluid can cause the seal to fail.

- a) Do not start up the pump without seal fluid.



TIP

A second connection on the product enables the quench chamber to be purged/flushed and the seal fluid to be drained.

7.4 Additional commissioning

- a) Open existing shut-off elements in front of and behind the product.
 - b) Set pressure relief valves installed in the system to the lowest opening pressure.
 - c) Start the product without pressure load or with low pressure (jog mode).
 - ⇒ A flow should have developed after 30 s at the latest.
 - d) Run the product pressureless or at low pressure for a few minutes.
 - e) Vent the system at the highest possible point.
 - f) Gradually increase the pressure up to the required operating pressure.
 - g) Operate the system until the final operating condition is reached.
 - h) Check the operating data.
 - ⇒ **Maintenance table [▶ 36]**
 - i) Document the operating data of the initial commissioning for later comparison.
 - j) Check the level of the operating medium in the system.
 - k) Check the level of the seal fluid (if present).
 - l) Check the product for leaks.
 - m) Check all fittings for leaks and retighten if necessary.
-



TIP

In order to ensure a constant and reliable function of the product, an initial maintenance of the product is recommended after several hours warm-up time (max. 24 h). This allows faults to be detected at an early stage.

8 Removal

8.1 Safety instructions for disassembly



⚠ DANGER

Hazardous fluids

Danger to life when handling hazardous fluids

- a) Comply with the safety data sheets and regulations on handling the hazardous fluids.
- b) Collect and dispose of hazardous fluids so that no hazard is created for persons or the environment.



⚠ DANGER

Rotating parts

Risk to life due to entanglement or winding of parts of the body, hair or clothing items.

- a) Before carrying out any work, disconnect any drives and actuators from the power supply or depressurise them.
- b) Safely prevent restarting during the work.



⚠ WARNING

Exposed gears

Gearwheels can trap and crush fingers and hands.

- a) Do not engage gearwheels.



⚠ WARNING

Failure of pressure bearing parts due to overload

Risk of injury from flying parts.

Risk of injury due to splashing fluids.

- a) Before carrying out any work, depressurise the product and all connection pipes.
- b) Securely prevent the pressure from being restored during work.



⚠ CAUTION

Hot surfaces

Burns of the skin on contact.

- a) At temperatures ≥ 48 °C, allow the product to cool first.

 **ATTENTION****Blocking of the product due to curing media**

Curing media can mechanically block the product and make it unusable.

- a) Clean the product immediately after operation with curing media.

8.2 Dismantling

- a) Depressurise and de-energise the system.
- b) Close existing shut-off elements in front of and behind the product.
- c) Open existing drain elements and undo connection lines. Collect and dispose of leaking media so that no hazard is created for persons or the environment.
- d) Dismantle the product.
- e) Clean the product.
- f) Seal the process connections and lines to prevent the ingress of dirt.

**NOTICE**

The concrete procedure for cleaning depends on the media being used.

- a) See the safety data sheet of the media in use.

9 Maintenance

9.1 Safety instructions for maintenance



DANGER

Hazardous fluids

Danger to life when handling hazardous fluids

- a) Comply with the safety data sheets and regulations on handling the hazardous fluids.
- b) Collect and dispose of hazardous fluids so that no hazard is created for persons or the environment.



DANGER

Rotating parts

Risk to life due to entanglement or winding of parts of the body, hair or clothing items.

- a) Before carrying out any work, disconnect any drives and actuators from the power supply or depressurise them.
- b) Safely prevent restarting during the work.



WARNING

Failure of pressure bearing parts due to overload

Risk of injury from flying parts.

Risk of injury due to splashing fluids.

- a) Before carrying out any work, depressurise the product and all connection pipes.
- b) Securely prevent the pressure from being restored during work.



CAUTION

Hot surfaces

Burns of the skin on contact.

- a) At temperatures ≥ 48 °C, allow the product to cool first.

9.2 Maintenance work



TIP

Checking and documentation of the operating data

Regular checking and documentation of all operating data helps to detect faults at an early stage.

- Perform the maintenance work according to specifications.
- Replace defective or worn components.
- If necessary, request spare parts lists and assembly drawings from the manufacturer.
- Document the type and scope of the maintenance work along with the operating data.
- Compare the operating data with the values of the initial commissioning.
In case of large deviations (> 10 %), determine the cause.
- Dispose of packaging materials and used parts according to local regulations.



NOTICE

Protective devices and notes

After maintenance and/or repair, reattach all protective devices and notices removed in the process to their original position.

9.3 Maintenance instructions

The following information provides recommendations for maintenance work and maintenance intervals for the product in use.

Depending on the actual loads occurring during operation, the type, scope and interval of the maintenance work may deviate from the recommendations. A mandatory maintenance plan must be drawn up by the installer/operating company.



TIP

In the course of preventive maintenance, it is advisable to replace wearing parts before the wear limit is reached.

With the appropriate know-how and sufficient equipment, the repair can also be carried out by the installer/operating company.

If necessary, request spare parts lists and assembly drawings from the manufacturer.

Please consult the manufacturer for this purpose.



NOTICE

Warranty

Any warranty will be void if not executed properly.

9.4 Maintenance table

9.4.1 Maintenance table

		Firstly:after max. 24 h	Daily	3000 Operating hours	6000 Operating hours	As required	Additional in-formation
9.4.2	Check the rate of flow	2					
9.4.3	Check the operating pressure	2					
9.4.4	Check the media temperature	2					
9.4.5	Check the device temperature	2					
9.4.6	Check the function of the add-on valve	2					
9.4.7	Check the equipotential bonding	2					
9.4.8	Check the condition of the operating fluid	2					
9.4.9	Auditory check Unusual noises		1				
9.4.10	Cleaning		1				
9.4.11	Visual inspection for leakage		1				
9.4.2	Check the rate of flow			2			
9.4.3	Check the operating pressure			2			
9.4.4	Check the media temperature			2			
9.4.5	Check the device temperature			2			
9.4.6	Check the function of the add-on valve			2			
9.4.7	Check the equipotential bonding			2			
9.4.8	Check the condition of the operating fluid			2			
9.4.12	Visual check of the gearbox condition				3		
9.4.13	Visual check of the condition of housing parts				3		
9.4.14	Visual check of the condition of the plain bearings				3		
9.4.15	Visual check of the condition shaft seal				3		
9.4.16	Visual check of the condition of the out-board bearing				3		
9.4.17	Replacing the outboard bearing					3	
9.4.18	Replacing the plain bearings					3	
9.4.19	Replacing the shaft seal					3	
9.4.20	Replacing other seals					3	

1 - 0,1 h; 2 - 0,2 h; 3 - 0,75 h

9.4.2 Check the rate of flow

The rate of flow is measured via the volumetric flow meter.

The values are displayed by the built-in controller in the electrical control system.

- If there is no discharge flow, check the individual components of the product.
- Comply with the product-specific data sheets/operating instructions.

9.4.3 Check the operating pressure

The operating pressure is indicated by the pressure gauges.

- If there is no operating pressure, check the individual components of the product.
- Comply with the product-specific data sheets/operating instructions.

9.4.4 Check the media temperature

The media temperature is measured through the temperature sensor.

The values are displayed by the built-in controller in the electrical control system.

- If the media temperature is too high or too low, check the product components.
- Comply with the product-specific data sheets/operating instructions.

9.4.5 Check the device temperature

Measure the surface temperature in the area of the bearing.

9.4.6 Check the function of the add-on valve

Add-on valves must be operated at regular intervals. This is necessary to ensure their faultless function.

9.4.7 Check the equipotential bonding

Check the equipotential bonding for tight fit and proper functioning.

9.4.8 Check the condition of the operating fluid

Pay attention to colour (dark colouring), odour and milky turbidity.

- Replace operating fluid if necessary.

9.4.9 Auditory check Unusual noises

In this case, attention must be paid to increased noise or uneven operation (pump unit).

- In case of unusual noises, examine the individual components of the product and line fixings and check the operating medium for foaming.
- Comply with the product-specific data sheets/operating instructions.

9.4.10 Cleaning

Remove dust deposits and dirt with a damp, clean cloth.

9.4.11 Visual inspection for leakage

Care must be taken here to ensure that there is no leakage from the connections.

- In the event of leaks in the connections, the glands must be tightened and, if necessary, the seals replaced.

9.4.12 Visual check of the gearbox condition

The driving shaft pinion and driven shaft pinion are wearing parts. In case of excessive wear, the parts or the pump must be replaced.

Important places to check are the surfaces opposite the shaft seal and bearing bushes, end faces of the driving shaft pinion and driven shaft pinion as well as the tooth flanks.

9.4.13 Visual check of the condition of housing parts

Important places to check are the end faces of the impeller chamber.

9.4.14 Visual check of the condition of the plain bearings

The plain bearings are wearing parts. In case of excessive wear, the parts or the pump must be replaced.

In case of multilayer plain bearings, the wear limit is reached if the bronze layer of the bearing is 50-70 % exposed.

When loaded on the suction side, the driving shaft pinion and driven shaft pinion are supported in the bearings so that wear is identified there first.

9.4.15 Visual check of the condition shaft seal

Pay attention to leak quantities and impermissible temperature increases.

- Small leaked quantities are indispensable for the function of the seal.
- In case of excessive leaked quantities or impermissible temperature increase, the pump must be shut down immediately. Replace the seal.

9.4.16 Visual check of the condition of the outboard bearing

The outboard bearing is a wearing part.

The life of the bearing primarily depends on the operating conditions.

The bearing should therefore be checked for damage after 4000 h at the latest. In the event of unacceptable wear, the bearing must be replaced.

Onsetting wear or pending failure can become noticeable due to increased heating of the bearing, increased power consumption, irregular running or even noise emissions.

9.4.17 Replacing the outboard bearing

With the appropriate know-how and adequate equipment, the repair can also be carried out by the installer/operating company.

To this end, if necessary, request spare parts and assembly drawings from the manufacturer.

Only use spare parts approved by the manufacturer.

9.4.18 Replacing the plain bearings

These are replaced only by the manufacturer.

Contact the manufacturer.

9.4.19 Replacing the shaft seal

With the appropriate know-how and adequate equipment, the repair can also be carried out by the installer/operating company.

To this end, if necessary, request spare parts and assembly drawings from the manufacturer.

Only use spare parts approved by the manufacturer.

9.4.20 Replacing other seals

With the appropriate know-how and adequate equipment, the repair can also be carried out by the installer/operating company.

To this end, if necessary, request spare parts and assembly drawings from the manufacturer.

Only use spare parts approved by the manufacturer.

10 Repair

10.1 Safety instructions for repairs



DANGER

Hazardous fluids

Danger to life when handling hazardous fluids

- a) Comply with the safety data sheets and regulations on handling the hazardous fluids.
- b) Collect and dispose of hazardous fluids so that no hazard is created for persons or the environment.



DANGER

Rotating parts

Risk to life due to entanglement or winding of parts of the body, hair or clothing items.

- a) Before carrying out any work, disconnect any drives and actuators from the power supply or depressurise them.
- b) Safely prevent restarting during the work.



WARNING

Failure of pressure bearing parts due to overload

Risk of injury from flying parts.

Risk of injury due to splashing fluids.

- a) Before carrying out any work, depressurise the product and all connection pipes.
- b) Securely prevent the pressure from being restored during work.



CAUTION

Hot surfaces

Burns of the skin on contact.

- a) At temperatures ≥ 48 °C, allow the product to cool first.

10.2 General

Corrective maintenance includes:

1. Troubleshooting
Finding damage, determining and localising the cause of the damage.
2. Damage repair
Removing the primary causes and replacing or repairing defective components. Repairs are generally carried out by the manufacturer.

Repair by the manufacturer

Before returning the product, fill out the return form. The form can be filled out online and is available to download as a pdf file or can be requested from the manufacturer.



NOTICE

Device contains hazardous substances

If the device has been operated with hazardous fluids it must be cleaned before it is returned. If this is not possible, the safety data sheet of the hazardous material must be provided in advance.

Repair by the installer/operating company

With the appropriate know-how and sufficient equipment, the repair can also be carried out by the installer/operating company. Please consult the manufacturer for this purpose.

- a) If necessary, request spare parts lists and assembly drawings from the manufacturer.
- b) Only use spare parts approved by the manufacturer.
- c) Dispose of packaging materials and used parts according to local regulations.



NOTICE

Warranty

Any warranty will be void if not executed properly.



NOTICE

Protective devices and notes

After maintenance and/or repair, reattach all protective devices and notices removed in the process to their original position.

10.3 Fault table

Fault	Potential causes	Possible measures
Increased noise		
Pump cavitation	Excessive negative pressure (not complete filling of the pump)	Check suction line design
		Use noise-optimised pump
	Suction line clogged	Clean the suction line
	Suction filter plugged or too small	Clean suction filter or use a larger filter
		Replace filter element
	Suction basket plugged or too small	Clean intake strainer or dimension larger
Fluid temperature too low	Fluid temperature too low	
Foaming or air in media	Pump does not suck	Check the oil level in the tank
		Check suction line
		Check the shaft seal
	Shaft seal defective	Replace seals
	Suction connection leaking	Tighten or replace the screw connections
		Replace seals
	System not vented	Vent the system
Return line ends above the fluid level	Extend return line	
Heavy foaming in the system, e.g. in gears	Use noise-optimised pump	
Mechanical vibrations	Incorrectly aligned and/or loose coupling	Correct the alignment of the coupling and secure the coupling halves
	Incorrectly and/or insufficient line fastening	Fixate lines with suitable fastening material (e.g. pipe clamps)
	Wobbling pressure relief valve	Increase valve opening pressure
	Not a noise-reducing setup	Use dampers
Pump does not suck		
	Dry run	Fill pump and the suction line with medium
	Minimum filling level in the reservoir tank undercut	Refill media
	Wrong direction of rotation	Correct the direction of rotation
	Throttled/closed shut-off element in the suction line	Open the shut-off element
	Suction line clogged	Clean the suction line

Pump does not suck		
	The air in the suction line cannot be compressed in the pressure line	Reduce the start-up pressure
		Vent the pressure line
		Increase volume of the pressure line
	Speed of the pump is too low	Check the pump design
		During frequency inverter operation: Check the operation/line frequency
	Geodetic suction head too high	Check installation location
Provide pre-filling pump		
Insufficient pressure		
Insufficient pumping flow rate		
	Excessive negative pressure (not complete filling of the pump)	Check suction line design
	Too high media viscosity	Provide pre-filling pump
	Speed of the pump is too low	Check the pump design
		During frequency inverter operation: Check the operation/line frequency
	Throttled/closed shut-off element in the suction line	Open the shut-off element
	Suction line clogged	Clean the suction line
	Suction filter plugged or too small	Clean suction filter or use a larger filter
		Replace filter element
	Suction bascket plugged or too small	Clean intake strainer or dimension larger
	Constant triggering of pressure relief valve (if existing)	Increase valve opening pressure
	Pump does not suck	Check the oil level in the tank
		Check suction line
Check the shaft seal		
Wear	Replace the device	
Excessive operating temperature		
	Cooling and heat dissipation insufficient	Increase the cooling capacity
	Not sufficient oil in the system	Check the container layout
	Excess fluid is being delivered into the supply tank via pressure relief valve under load	Check the pump design

Impermissible pump heating		
	Constant triggering of pressure relief valve (if existing)	Increase valve opening pressure
	Pressure too high in association with a media viscosity that is too low	Check the system design
	Speed too fast in connection with media viscosity that is too high	Check the system design
	Gland lid overtightened (for gland seal)	Unscrew gland lid and readjust leakage
	Suction pressure too high	Reduce the pressure
	Wear	Replace the device
Leakage		
Seal failure	Lack of maintenance	Comply with maintenance inter-vals
		Replace seals
	Mechanical damage	Replace seals
	Thermal overload	Check operating data
		Replace seals
	Pressure too high	Check operating data
		Replace seals
	Gas content in media too high	Check operating data
		Replace seals
	Corrosion/chemical degradation	Check material compatibility
Replace seals		
Wrong direction of rotation	Correct the direction of rotation	
	Replace seals	
Contaminated medium	Provide filtration	
	Replace seals	
Gland lid not sufficiently tightened (for gland seal)	Retighten gland lid	
Loose screw connection	Tighten or replace the screw connections	
Coupling		
Coupling wear	Alignment error	Correct the alignment of the coupling and secure the coupling halves
	Spider overloaded	Check operating data
		Use harder spider
Cam break	Spider wear Torque transmission due to metal contact	Adapt maintenance intervals
		Replace coupling

Premature spider wear	Alignment error	Correct the alignment of the coupling and secure the coupling halves
		Replace spider
	Spider failure due to chemical corrosion	Check material compatibility
		Replace spider
Motor protection switch tripped		
	Driving power too low	Check the drive design
	Motor incorrectly connected	Check motor connection
	Phase failure	Check feed/supply
	Current consumption too high	Check operating data
		Check direction of rotation
Motor circuit breaker incorrectly designed	Check operating data	
Consult the manufacturer in the event of unidentifiable faults		