

# KRACHT

D.0034510002

## Operating instructions (Translation)

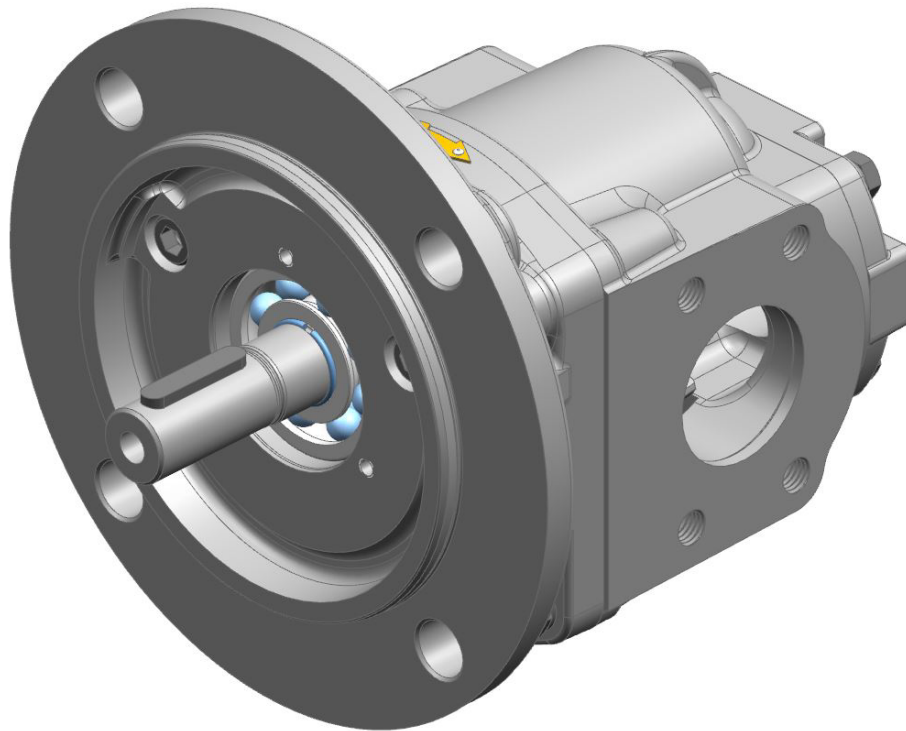

Gear pump KF 3-6  
Magnetic coupling MINEX® -S  
English

# Table of content

<b>1 General .....</b>	<b>5</b>
1.1 About the documentation .....	5
1.2 Manufacturer address .....	5
1.3 Other applicable documents .....	5
1.4 Symbols.....	6
<b>2 Safety.....</b>	<b>7</b>
2.1 Intended use.....	7
2.2 Personal qualification .....	7
2.3 Basic safety instructions .....	8
2.4 Fundamental hazards .....	8
2.5 Special hazards .....	10
<b>3 Device description.....</b>	<b>11</b>
3.1 Functional principle.....	11
3.1.1 Magnetic coupling .....	12
3.2 Variants .....	13
3.2.1 Magnetic coupling .....	15
3.3 Type key.....	16
3.3.1 Type key magnetic coupling .....	18
3.4 Direction of rotation and discharge .....	18
3.5 Special numbers .....	18
3.6 Shaft ends .....	19
<b>4 Technical data.....</b>	<b>20</b>
4.1 General.....	20
4.2 Nominal sizes.....	21
4.3 Assignment of viscosity - speed.....	22
4.4 Allowable pressures .....	22
4.4.1 Operating pressure, suction and pressure side .....	22
4.5 Assignment of differential pressure to viscosity .....	23
4.6 Permissible temperature range .....	24
4.6.1 Gear pump with magnetic coupling .....	25
4.7 Material data.....	25
4.7.1 Compressor application .....	27
4.8 Weight.....	28
4.9 Dimensions.....	28
<b>5 Transport and storage .....</b>	<b>29</b>
5.1 General.....	29
5.2 Transport.....	29
5.3 Storage.....	29
5.4 Storage conditions .....	30

5.5	Special hazards .....	31
<b>6</b>	<b>Installation .....</b>	<b>32</b>
6.1	Safety instructions for installation .....	32
6.1.1	Special hazards .....	33
6.2	Noise reduction .....	34
6.3	Mechanical installation .....	34
6.3.1	Preparation.....	34
6.3.2	Gear pump for magnetic coupling .....	35
6.4	Connection lines.....	36
6.4.1	General.....	36
6.4.2	Suction line.....	37
6.4.3	Pressure pipe.....	38
6.4.4	Connection line installation.....	38
6.5	Change of the direction of rotation.....	39
6.5.1	Gear pump without noise optimisation.....	39
<b>7</b>	<b>Commissioning.....</b>	<b>41</b>
7.1	Safety instructions for start-up.....	41
7.1.1	Special hazards.....	41
7.2	Preparation.....	42
7.3	Pressure valve setting.....	42
7.3.1	Pressure relief valve .....	43
7.4	Additional commissioning.....	43
<b>8</b>	<b>Removal.....</b>	<b>44</b>
8.1	Safety instructions for disassembly.....	44
8.1.1	Special hazards.....	45
8.2	Dismantling .....	46
<b>9</b>	<b>Maintenance .....</b>	<b>47</b>
9.1	Safety instructions for maintenance.....	47
9.1.1	Special hazards.....	48
9.2	Maintenance work.....	49
9.3	Maintenance instructions.....	49
9.4	Maintenance table.....	50
9.4.1	Maintenance table.....	50
9.4.2	Check the rate of flow.....	51
9.4.3	Check the operating pressure.....	51
9.4.4	Check the media temperature.....	51
9.4.5	Check the device temperature .....	51
9.4.6	Check the function of the add-on valve .....	51
9.4.7	Check the equipotential bonding .....	51
9.4.8	Check the condition of the operating fluid .....	51
9.4.9	Auditory check Unusual noises .....	51
9.4.10	Cleaning .....	51
9.4.11	Visual inspection for leakage .....	52
9.4.12	Visual check of seal fluid level.....	52
9.4.13	Visual check of the gearbox condition.....	52
9.4.14	Visual check of the condition of housing parts .....	52

---

9.4.15	Visual check of the condition of the plain bearings .....	52
9.4.16	Visual check of the condition shaft seal .....	52
9.4.17	Visual check of the condition of the outboard bearing .....	53
9.4.18	Replacing the outboard bearing .....	53
9.4.19	Replacing the plain bearings.....	53
9.4.20	Replacing the shaft seal .....	53
9.4.21	Replacing other seals .....	53
<b>10</b>	<b>Repair .....</b>	<b>54</b>
10.1	Safety instructions for repairs .....	54
10.1.1	Special hazards .....	55
10.2	General.....	56
10.3	Fault table .....	57

# 1 General

## 1.1 About the documentation

These operating instructions describe the installation, operation and maintenance of the following product:

**Gear pump KF 3-6**

**Magnetic coupling MINEX® -S**

These operating instructions are an integral part of the product and must be kept in the immediate vicinity of the

product and accessible to the personnel at all time.

Different versions of the product are produced. Which version is concerned is stated on the device's type plate.

If you have any questions about this operating manual, please contact the manufacturer.

## 1.2 Manufacturer address

KRACHT GmbH  
Gewerbestraße 20  
D-58791 Werdohl  
Tel: +49 2392 935-0  
Fax: +49 2392 935-209  
Email: [info@kracht.eu](mailto:info@kracht.eu)  
Web: [www.kracht.eu](http://www.kracht.eu)

## 1.3 Other applicable documents

In addition to these instructions, also comply with the relevant instructions of plants or plant parts available or planned on site.

## 1.4 Symbols



### **DANGER**

Identification of an immediate hazard, which can lead to death or severe bodily injury if not avoided.



### **WARNING**

Identification of a potential medium risk hazard, which can lead to death or severe bodily injury if not avoided.



### **CAUTION**

Identification of a possible low-risk hazard that can result in minor or moderate physical injury if not avoided.

### **ATTENTION**

Identification of notes to prevent property damage.



### **NOTICE**

Identification of basic safety instructions. Non-compliance can lead to hazards for people and the product



### **TIP**

Identification of special user tips and other particularly useful or important information

## 2 Safety

### 2.1 Intended use

1. The product has been designed for operation with fluids.  
Dry operation is not permitted.
2. The product may only be operated when completely filled.
3. The fluid must be compatible with the materials used in the product. Chemical expertise is required for that. Be careful with ethylene oxide or other catalytically or exothermically reacting or self-decomposing substances. Please consult the manufacturer in cases of doubt.
4. The product may only be used in normal industrial atmospheres. If there are any aggressive substances in the air, always consult the manufacturer.
5. The product may only be operated in compliance with these operating instructions and the applicable documents.  
Deviating operating conditions require the express approval of the manufacturer.
6. Use of the product for purposes other than those for which it is intended invalidates any warranty.
7. The product may only be operated in combination with a magnetic coupling.

### 2.2 Personal qualification

The personnel charged with the assembly, operation and maintenance of the product must have the necessary qualifications.

This can be achieved through training or appropriate instruction.

The personnel must be familiar with the contents of these operating instructions.



#### NOTICE

Read the operating instructions in full before using the product.

## 2.3 Basic safety instructions



### NOTICE

#### Basic safety instructions

Non-compliance can lead to hazards for people and the unit.

- a) Follow existing regulations for accident prevention and safety at work as well as the internal regulations of the operating company.
- b) Ensure the greatest possible cleanliness.
- c) Wear suitable personal protective equipment.
- d) Do not remove type plates or other information or make them illegible or unrecognisable.
- e) Do not make any technical modifications.
- f) Comply with maintenance intervals.
- g) Only use spare parts approved by the manufacturer.

## 2.4 Fundamental hazards



### ⚠ DANGER

#### Hazardous fluids

Danger to life when handling hazardous fluids

- a) Comply with the safety data sheets and regulations on handling the hazardous fluids.
- b) Collect and dispose of hazardous fluids so that no hazard is created for persons or the environment.



### ⚠ DANGER

#### Hazardous fluids

Danger to life when handling hazardous fluids.

- a) Defective components and connection lines must be replaced or fixed without delay.
- b) Use only components and connection lines approved for the expected pressure range.



### ⚠ DANGER

#### Rotating parts

Risk to life due to entanglement or winding of parts of the body, hair or clothing items.

- a) Before carrying out any work, disconnect any drives and actuators from the power supply or depressurise them.
- b) Safely prevent restarting during the work.



**⚠ DANGER****Rotating parts**

Risk to life due to entanglement or winding of parts of the body, hair or clothing items.

- a) Take measures to prevent accidental touching of rotating parts.

**⚠ WARNING****Rotating parts**

Risk of injury caused by ejected parts

- a) Enclose rotating parts so that in the event of fracture or malfunction, there is no risk caused by ejected parts.

**⚠ WARNING****Failure of pressure bearing parts due to overload**

Risk of injury from flying parts.

Risk of injury due to splashing fluids.

- a) Before carrying out any work, depressurise the product and all connection pipes.
- b) Securely prevent the pressure from being restored during work.

**⚠ WARNING****Failure of pressure bearing parts due to overload**

Risk of injury from flying parts.

Risk of injury due to splashing fluids.

- a) Use only connections and lines approved for the expected pressure range.
- b) Securely prevent the permissible pressures from being exceeded, e.g. by using pressure relief valves or bursting discs.
- c) Pipelines must be designed in such a way that no tension e.g. caused by changes in length due to fluctuations in temperature can be transferred to the product.

**⚠ WARNING****Failure of pressure bearing parts due to overload**

Risk of injury caused by flying parts.

Risk of injury caused by splashing fluids.

- a) Do not operate the product with shut-off devices closed.
- b) Do not operate the production in the wrong rotational direction.

## 2.5 Special hazards



### **DANGER**

#### **Strong magnetic field**

Risk to life for people with active implanted cardiac devices

- a) Maintain a safety distance of at least 2 m from unmounted components of the magnetic coupling.
- b) Maintain a safety distance of at least 0.5 m from couplings to be installed with axially aligned magnetic rotors and surrounding bell housing (pump support).



### **WARNING**

#### **Strong magnetic field**

Risk of injury caused by uncontrolled mutual attraction between magnetic or magnetisable parts.

- a) When performing any work, bear in mind the magnetic forces which occur, especially within 0.5 m of the magnetic coupling.

### **ATTENTION**

#### **Powerful magnetic field**

Magnetic data carriers (discs, credit cards, etc.) can be damaged or erased by magnetic fields.

- a) Maintain a minimum clearance of 1 m to the magnetic field.

## 3 Device description

### 3.1 Functional principle

The pumps of this series are external gear pumps, which operate according to the displacement principle.

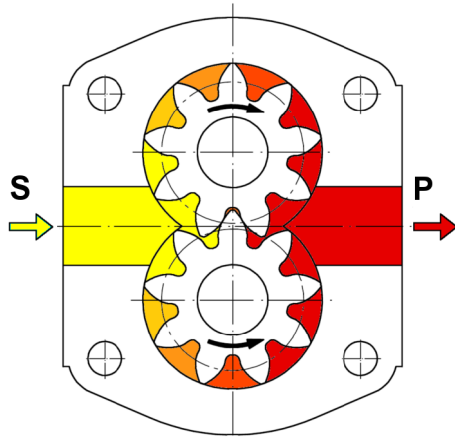

S Suction connection  
P Pressure connection

During rotation, two interlocking gears cause a volume increase by opening the tooth spaces on the suction side (S), so that the medium can flow in and at the same time, on the discharge side (pressure side, P), a corresponding volume is displaced by the meshing of the teeth in the filled tooth gaps. Fluid transport takes place through entrainment in the tooth spaces along the wall of the wheel chamber.

With each gear rotation, the so-called geometric displacement volume  $V_g$  is displaced.

A value that is named the rated volume  $V_{gn}$  in technical documents to specify the pump size.

The displacement process described takes place initially without a noticeable pressure build-up. Only after external loads are applied, e.g. by head, flow resistances, pipe elements, etc., does the required working pressure set in to overcome these resistances.

The pressure applied to the shaft seal equals the pressure at the suction connection of the product. The permissible pressure is determined by the type of seal.

### 3.1.1 Magnetic coupling

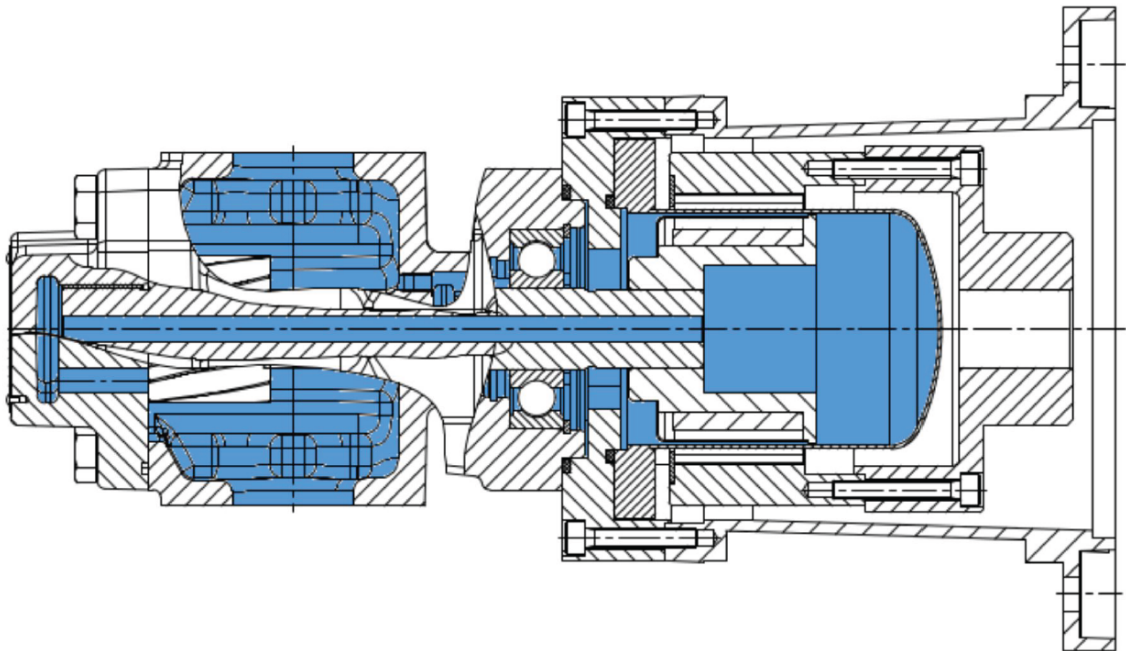

Versions with magnetic coupling are used when absolute leak-proofness is required on the shaft seal or when being operated with supply pressure on the suction side. The magnetic coupling is leak-proof within the permissible technical limits.

This magnetic coupling has the exterior rotor installed on the motor shaft and the interior rotor on the pump shaft. The torque is transmitted between the two rotors via magnetic force. A separating can installed in-between the two rotors provides hermetic sealing of the pump.

The device can be used in vacuum mode, e.g. for filling brake fluid, while doing so, the penetration of air into the system is reliably prevented. Leakagefree operation is ensured during operation in closed systems that have the system pressure applied on the suction side.

On versions with rinsing, an internal forced rinsing of the interior rotor by the pumping medium is provided for continuous removal of the heat developing in the air gap. The magnetic coupling is cooled by a substream of the pumping medium.

## 3.2 Variants

### Gear pump

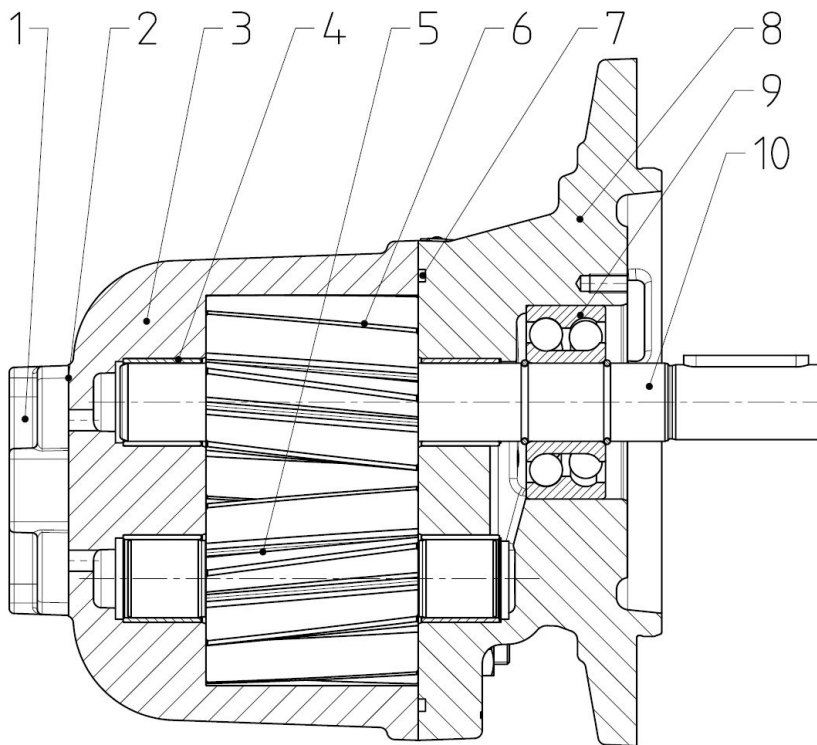

- |   |                 |    |                    |
|---|-----------------|----|--------------------|
| 1 | End cover       | 2  | O-ring             |
| 3 | Housing         | 4  | Plain bearings     |
| 5 | Driven shaft    | 6  | Gears              |
| 7 | O-ring          | 8  | Flange cover       |
| 9 | Roller bearings | 10 | End of drive shaft |

**Gear pump with pressure relief valve**

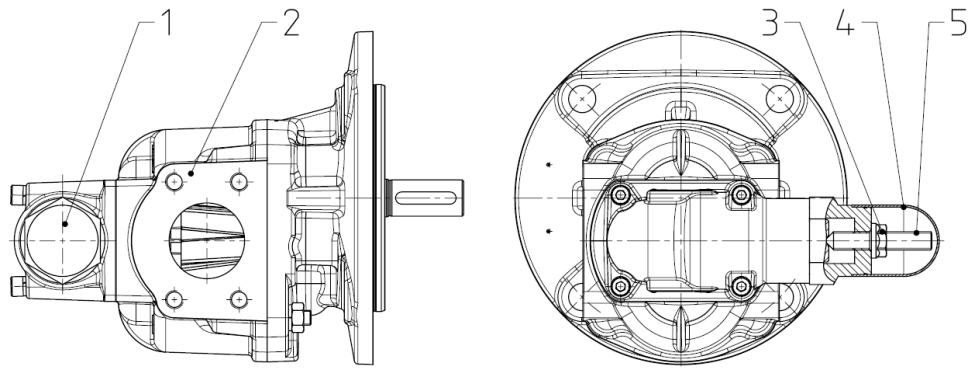

- 1 Pressure relief valve
- 3 Collar nut
- 5 Adjustment screw

- 2 Gear pump
- 4 Cover

**Valve cover**

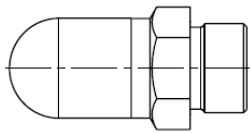

Thread protective cap

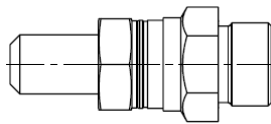

Cap nut

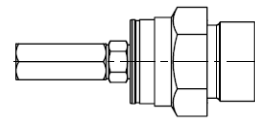

Cap nut KN17

### 3.2.1 Magnetic coupling

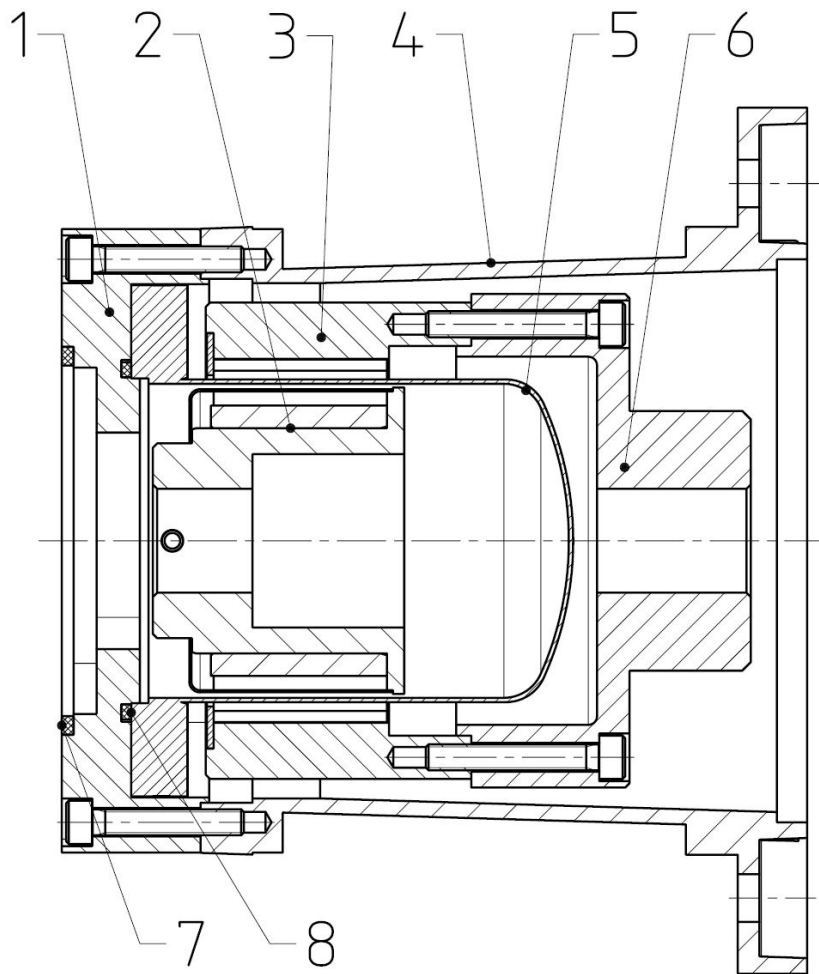

- |                      |                  |
|----------------------|------------------|
| 1 Adapter flange     | 2 Internal rotor |
| 3 External rotor     | 4 Bellhousing    |
| 5 Containment shroud | 6 Flange hub     |
| 7 O-ring             | 8 O-ring         |

### 3.3 Type key

Ordering example																		
KF		3/	63		F	1	0	B		N	0	0		7	D	P	65	/197
1.		2.	3.		4.	5.	6.	7.		8.	9.	10.		11.	12.	13.	14.	15.

Ordering example			
+		<b>DKF 3</b>	<b>D</b>
		16.	17.
			<b>04</b>
			18.

Explanation of type key			
<b>1. Product name</b>			
<b>2. Size</b>			
<b>3</b>	<b>4</b>	<b>5</b>	<b>6</b>
<b>3. Nominal</b>			
$V_{gn}$	<b>KF 3/.</b> : 63; 80; 100; 112 <b>KF 4/.</b> : 125; 150; 180 <b>KF 5/.</b> : 200; 250; 315 <b>KF 6/.</b> : 400; 500; 630; 730		
<b>4. Fixing type</b>			
<b>F</b>	KF 3/. A-Ø= 180; Z-Ø= 130; LK-Ø= 150	<b>H</b>	KF 5/. – KF 6/. A-Ø= 250; Z-Ø= 180; LK-Ø= 215
<b>G</b>	KF 4/. A-Ø= 220; Z-Ø= 150; LK-Ø= 185		
A= Outer diameter; Z= Centering diameter; LK=Bolt circle			
<b>5. Direction of rotation</b>			
<b>1</b>	Clockwise	<b>2</b>	Counterclockwise
<b>6. Outboard flange</b>			
<b>0</b>	Without		
<b>7. Construction of housing</b>			
<b>B</b>	Housing with flange connection		
<b>8. Shaft end</b>			
<b>N</b>	Cylindrical shaft end with roller bearings		
<b>9. 2nd shaft end</b>			
<b>0</b>	Without		
<b>10. End cover</b>			
<b>A</b>	Only for direction of rotation 1 or 2	<b>0</b>	Without end cover (For valve installation)
<b>11. Design serial number (specified by manufacturer)</b>			



<b>Explanation of type key</b>			
<b>12. Housing material and plain bearing</b>			
<b>D</b>	EN-GJL-250 Multi layer friction bearings (contains lead)	<b>V</b>	EN-GJS-400-15 Multi layer friction bearings (contains lead)
<b>13. Gears version</b>			
<b>P</b>	Helical gear		
<b>14. Seal type</b>			
<b>60</b>	without rinsing O-ring EPDM	<b>67</b>	with rinsing O-ring HNBR
<b>61</b>	without rinsing O-ring FKM	<b>81</b>	with rinsing O-ring FEPM
<b>62</b>	with rinsing O-ring CR	<b>83</b>	with rinsing O-ring FEP with silicone-core
<b>65</b>	with rinsing O-ring FKM	<b>91</b>	with rinsing O-ring FFKM
<b>15. Special number</b>			
<b>Special numbers [ ▶ 18]</b>			
<b>16. Pressure relief valve</b>			
<b>DKF 3</b>	For KF 3/.	<b>DKF 5</b>	For KF 5/.
<b>DKF 4</b>	For KF 4/.	<b>DKF 6</b>	For KF 6/.
<b>17. Pressure relief valve</b>			
<b>U</b>	Housing material: EN-GJL-250	<b>V</b>	Housing material: EN-GJS-400-15
	O-ring: Material defined by pump		O-ring: Material defined by pump
	Cover: Thread protective cap		Cover: Cap nut
<b>W</b>	Housing material: EN-GJL-250		
	O-ring: Material defined by pump		
	Cover: Cap nut		
<b>18. Pressure setting ranges</b>			
<b>04</b>	2 – 4 bar	<b>16</b>	8 – 16 bar
<b>08</b>	4 – 8 bar	<b>25</b>	16 – 25 bar

### 3.3.1 Type key magnetic coupling

Ordering example							
<b>MSC75</b>	-	<b>A</b>	-	<b>2</b>	-	<b>FKM</b>	
1.		2.		3.		4.	

Explanation of type key			
<b>1. Coupling size</b>			
MSA46; MSA60; MSB60; MSA75; MSB75; MSC75; MSB110; MSC110; MSC110S; MSC135; MSC135S; MSD135; MSD135S; MSD165; MSE165; MSD200			
<b>2. Maximum operating temperature</b>			
<b>A</b>	150 °C	<b>B</b>	300 °C
<b>3. Pressure range</b>			
<b>1</b>	16 bar	<b>3</b>	40 bar
<b>2</b>	25 bar	<b>4</b>	60 bar
<b>4. Material O-ring</b>			

### 3.4 Direction of rotation and discharge

The direction of rotation is indicated by the curved arrow, when looking towards the end of the drive shaft. The pump connections are below the drive shaft.

The flow direction is indicated by the straight arrow.

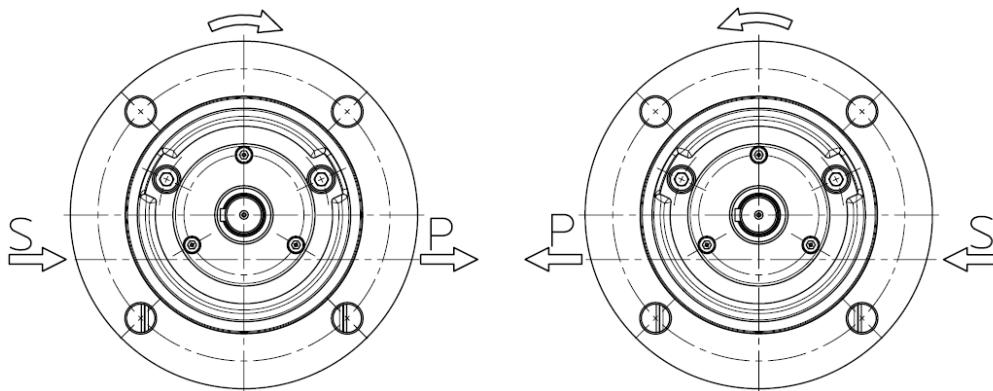

S = Suction connection  
P = Pressure connection

### 3.5 Special numbers

Special number	Description
<b>197</b>	Noise-optimized version for oils containing air
<b>273</b>	White metal bearing + <b>Special number 197</b>
<b>304</b>	Plastic plain bearings (non-ferrous metal-free)
<b>317</b>	Combination of <b>Special number 197 + 304</b>

Special number	Description
332	<b>Special number 304</b>
346	<b>For compressor applications</b> Plastic plain bearings (non-ferrous metal-free)
347	<b>For compressor applications</b> Plastic plain bearings (non-ferrous metal-free) End cover as suction connection with adapter plate
373	Plastic plain bearings (non-ferrous metal-free) Neutral type plate
489	<b>For compressor applications</b> Plastic plain bearings (non-ferrous metal-free) But with sonder ball bearing (Bearing railroad with ATC-chrome layer, ceramic rolling elements)
528	<b>For compressor applications</b> <b>Special number 346</b> Stainless steel type plate

### 3.6 Shaft ends

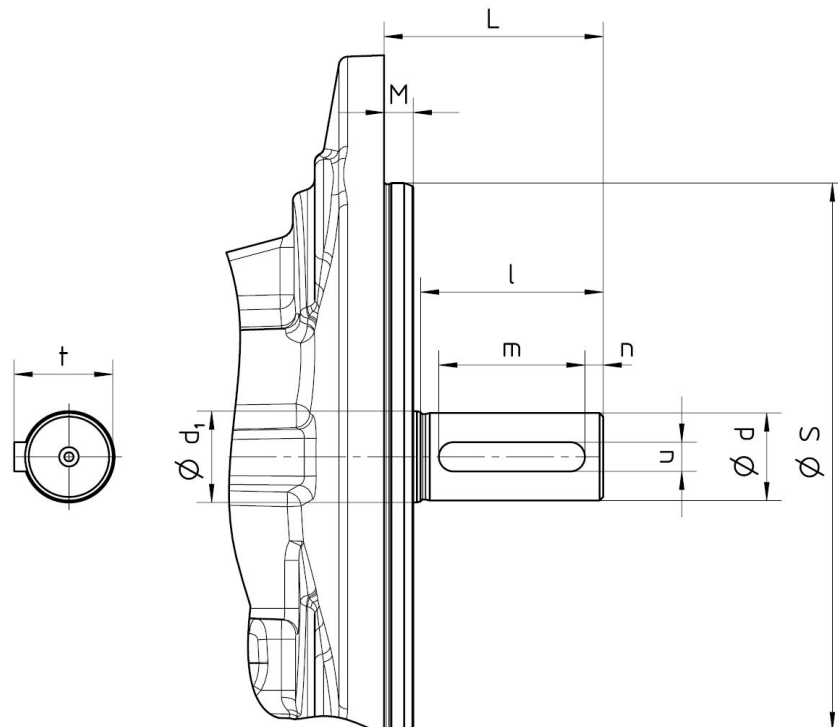

Size	Shaft end	Special number	L	S <sub>h6</sub>	M	d <sub>k6</sub>	d <sub>1</sub>	l	m	n	t	u
<b>KF 3</b>	N-Shaft	-	60	130	5	24	35	50	30	10	27	8
<b>KF 4</b>	N-Shaft		60	150	8	24	25	50		5	27	8
<b>KF 5</b>	N-Shaft		70	180		28	30	60	40	10	31	8
<b>KF 6</b>	N-Shaft		95		38	40	80	63	8	41	10	

## 4 Technical data

### 4.1 General

General information				
Housing connection	KF 3/.		Flange connection	SAE 1 1/2" – M10
	KF 4/.			SAE 2"
	KF 5/200			SAE 2 1/2"
	KF 5/250 – KF 5/315			SAE 3" – M12
	KF 6/.			SAE 4"
Mounting position		Any		
External loads on shaft end		Axial and radial forces are not allowed		
Speed	n	Nominal sizes [▶ 21] + Assignment of viscosity - speed [▶ 22]		
Operating pressure	p <sub>e</sub>	Allowable pressures [▶ 22]		
	p <sub>b</sub>			
Viscosity	v <sub>min</sub>	Assignment of viscosity - speed [▶ 22]		
	v <sub>max</sub>	8000 mm <sup>2</sup> /s		
Fluid temperature	ϑ <sub>m</sub>	Permissible temperature range [▶ 24]		
Ambient temperature	ϑ <sub>u</sub>			
Filtering	β	≤ 60 μm		
Materials		Material data [▶ 25]		
Permissible media		Lubricating fluids without abrasive components Fluids with constituents that can be magnetised are not permissible (Petrols, solvents, etc. are not permissible) For compressor applications : Refrigeration oil (max. 5% gas content), Hydraulic oil; Mineral oil		

Magnetic coupling					
Coupling size	Rated torque [Nm] at 20 °C				
	Pressure range 9 bar	Pressure range 16 bar	Pressure range 25 bar	Pressure range 40 bar	Pressure range 60 bar
MSA46	-	3	-	-	-
MSA60	-	-	-	7	7
MSB60	-	-	-	14	14
MSA75	10	-	-	-	-
MSB75	-	24	24	-	24
MSC75	-	40	40	-	40
MSB110	-	-	60	60	54
MSC110	-	-	95	95	77

Magnetic coupling					
Coupling size	Rated torque [Nm] at 20 °C				
	Pressure range 9 bar	Pressure range 16 bar	Pressure range 25 bar	Pressure range 40 bar	Pressure range 60 bar
MSC135	-	-	145	-	125
MSD135	-	-	200	-	160
MSD165	-	-	280	-	-
MSE165	-	-	370	-	-
MSD200	-	-	430	-	-

## 4.2 Nominal sizes

Nominal $V_{gn}$	Geom. displacement $V_g$ [cm <sup>3</sup> /rev.]	Speed		Sound pressure level $L_{pA}^{(1)}$ [dBA]	Mass inertia $x10^{-4}$ J (kg m <sup>2</sup> )
		$n_{min}$	$n_{max}^{(2)}$		
KF 3/63	63.8	200	2000	≤ 75	4.25
KF 3/80	81.3			≤ 76	5
KF 3/100	100.8			≤ 77	6.75
KF 3/112	112.6			≤ 78	7.5
KF 4/125	129			≤ 79	13.75
KF 4/150	153			≤ 80	16
KF 4/180	184			≤ 81	19.25
KF 5/200	204			≤ 82	27.5
KF 5/250	255			≤ 82	34.5
KF 5/315	321			≤ 83	43
KF 6/400	405			≤ 84	105
KF 6/500	505			≤ 85	130
KF 6/630	629			≤ 85	160
KF 6/730	730		1500	≤ 85	195

<sup>(1)</sup>  $n= 1500$  rpm;  $v= 34$  mm<sup>2</sup>/s;  $p= 5-25$  bar

<sup>(2)</sup> Pay attention to the viscosity

## 4.3 Assignment of viscosity - speed

Kinematic viscosity $\nu$ [mm <sup>2</sup> /s]	Recommended rpm $n$ [rpm]
400	2000
500	1800
1000	1200
2000	800
5000	500
10000	350
15000	250



### TIP

Select the speed of rotation so that complete filling of the pump is ensured. This is the case if the pressure on the suction side does not fall below the permissible pressure  $p_{e \text{ min}}$ .

## 4.4 Allowable pressures

### 4.4.1 Operating pressure, suction and pressure side

Gear pump			
Housing material	Operating pressure		
	Suction side		Pressure side
	$p_{e \text{ min}}$ [bar <sub>abs.</sub> ]	$p_{e \text{ max}}$ [bar <sub>rel.</sub> ]	$p_b$ [bar <sub>rel.</sub> ] (perm. continuous pressure)
EN-GJL-250	0.6 <sup>(1)</sup>	35	35
EN-GJS-400-15	Vacuum equipment: 0.08 Standing still: 0	60	60

**bar<sub>abs.</sub>** = Absolute pressure ; **bar<sub>rel.</sub>** = Relative pressure

<sup>(1)</sup> Start-up condition: 0.4 bar absolute (max. 30 minutes)

Gear pump with magnetic coupling (Minex®)				
Housing material	Pressure range Magnetic coupling	Operating pressure		
		Suction side		Pressure side
		$p_{e \text{ min}}$ [bar <sub>abs.</sub> ]	$p_{e \text{ max}}$ [bar <sub>rel.</sub> ]	$p_b$ [bar <sub>rel.</sub> ] (perm. continuous pressure)
EN-GJL-250	1	0.6 <sup>(1)</sup>	16	35
---	2; 3; 4	Vacuum equipment: 0.08	25	
EN-GJS-400-15		3	Standing still: 0	40
EN-GJS-400-15	4		60	60

Gear pump with magnetic coupling (Minex®)				
Housing material	Pressure range Magnetic coupling	Operating pressure		
		Suction side		Pressure side
		$p_{e\ min}$ [bar <sub>abs.</sub> ]	$p_{e\ max}$ [bar <sub>rel.</sub> ]	$p_b$ [bar <sub>rel.</sub> ] (perm. continuous pressure)
	3		40	40
	4		60	60

**bar<sub>abs.</sub>** = Absolute pressure ; **bar<sub>rel.</sub>** = Relative pressure

<sup>(1)</sup> Start-up condition: 0.4 bar absolute (max. 30 minutes)

## 4.5 Assignment of differential pressure to viscosity

Plain bearings	$\Delta p_{max}$ [bar]		
	$\nu = 1,4\ mm^2/s$	$\nu = 6\ mm^2/s$	$\nu = 12\ mm^2/s$
Multi layer friction bearings (contains lead) (Standard)	3	12	KF 3/.
			KF 4/.
			KF 5/200
			KF 5/250
			KF 5/315
Multi layer friction bearings (non-ferrous metal-free)	3	12	KF 6/400
			KF 6/500
			KF 6/630
			KF 6/730
Plastic plain bearings	-	3	10 <sup>(1)</sup>
White metal bearing			KF 6/730: 6 <sup>(1)</sup>

<sup>(1)</sup> For compressor applications  $\nu \geq 7\ mm^2/s$

## 4.6 Permissible temperature range

Sealing material	Fluid temperature $\vartheta_m$	
	$\vartheta_{m \min}$ [°C]	$\vartheta_{m \max}$ [°C]
CR	-20	100
EPDM - peroxide cured		130
FKM		150
FFKM		200
HNBR		150
FEPM	-10	200
FEP with silicone-core	-30	200

Sealing material	Ambient temperature $\vartheta_u$	
	$\vartheta_{u \min}$ [°C]	$\vartheta_{u \max}$ [°C]
CR	-20	60
EPDM - peroxide cured		
FKM		
FFKM		
HNBR		
FEPM	-10	
FEP with silicone-core	-30	



### NOTICE

Note media-specific properties.



### NOTICE

Size 3 gear pumps for compressor application have bearing material Iglidur® G, here is the fluid temperature  $\vartheta_{m \max}$  110 °C.



### 4.6.1 Gear pump with magnetic coupling

Sealing material	Fluid temperature $\vartheta_m$		
	$\vartheta_{m \text{ min}}$ [°C]	$\vartheta_{m \text{ max}}$ [°C]	
		Pressure range Magnetic coupling	
		A	B
CR	-20	100	100
EPDM - peroxide cured		130	130
FKM		150	150
FFKM		150	200
HNBR		150	150
FEPM	-10	150	200
FEP with silicone-core	-30	150	200

#### ATTENTION

##### Eddy current losses

Metal separating cans in a magnetic coupling will always induce eddy current losses within the rotating magnetic field that are converted into heat.

- a) When using pump design variants without circulating fluid, be sure to account for increases in temperature caused by eddy current losses.

## 4.7 Material data

Gear pump					
Seal type	Materials				
	O-ring	Housing / End cover / Valve housing	Gears	Plain bearings	Typeplate / Grooved studs
60	EPDM	EN-GJL-250 --- EN-GJS-400-15	Casehardened steel  16MnCrS5 - 1.7139	Multi layer friction bearings (contains lead)  (Steel (St), CuSn, PTFE, Pb) --- Plastic plain bearings (non-ferrous metal-free) Iglidur® ---	Aluminium (Al) (percent by weight Mg ≤ 7.5 %)
61	FKM				
62	CR				
65	FKM				
67	HNBR				
81	FEPM				
83	FEP with silicone-core				

Gear pump					
Seal type	Materials				
	O-ring	Housing / End cover / Valve housing	Gears	Plain bearings	Typeplate / Grooved studs
91	FFKM			Multi layer friction bearings (non-ferrous metal-free) DP4 (Steel (St), CuSn, PTFE) - - - White metal bearing (Steel (St), SnSb12Cu5Cd or SnSb12Cu6) (KF 2.5-80)	

Magnetic coupling					
Maximum operating temperature	Materials				
	Internal rotor	External rotor	Containment shroud	Bellhousing	Other materials
150 °C (A)	1.4571 / Sm2co17	Steel (St) / Nd-FeB - - - Steel (St) / Sm2Co17	1.4571 - - - 1.4571 / Hastelloy	Aluminium (Al) (percent by weight Mg ≤ 7.5 %)	Steel (St)
300° (B)		Steel (St) / Sm2Co17			

## 4.7.1 Compressor application

Refrigerant		Oil							
		M	M*	M*-PAO	AB	E	PAO	AB-PAO	PAG
<b>R717 (NH3)</b>	Ammonia	CR / HNBR	CR / HNBR	CR / HNBR	CR	-	CR <sup>(1)</sup> / HNBR	CR	CR / HNBR
<b>R290 (C3H8)</b>	Propane	-	-	-	-	-	HNBR	-	HNBR
<b>R1270 (C3H6)</b>	Propylene	-	-	-	-	-	HNBR	-	HNBR
<b>R744 (CO2)</b>	Carbon dioxide	-	-	-	-	CR	HNBR	-	HNBR
<b>R22</b>	H-CFC	CR	-	-	CR	CR	-	CR	-
<b>R134a, R404a, R407C, R410A, R507, R23</b>	H-FC	-	-	-	-	HNBR	-	-	-
<sup>(1)</sup> only for oils: Fuchs Reniso Synth 68, Klüber Summit R100/R150/R200 M= Mineral oil M*= Mineral oil with special treatment (hydrocracked oil) AB= Alkylbenzene E= Polyester PAO= Polyalphaolefin PAG= Polyalkylglykol									

## 4.8 Weight

Nominal $V_{gn}$	Gear pump with [kg]	
	End cover	Pressure relief valve
KF 3/63	12	13.5
KF 3/80		
KF 3/100	13.5	15
KF 3/112		
KF 4/125	18.5	20
KF 4/150	20	21.5
KF 4/180	21	22.5
KF 5/200	28	30
KF 5/250	33	35
KF 5/315		
KF 6/400	51	59
KF 6/500	55	63
KF 6/630	65	73
KF 6/730		

Size	Magnetic coupling [kg]							
	MSB 75	MSC 75	MSB 110	MSC 110	MSC 135	MSD 135	MSD 165	MSE 165
KF 3	10	11.6	29	31	-	-	-	-
KF 4	-	17	23	25	-	34	-	-
KF 5	-	-	27	30	34	38	61	-
KF 6	-	-	-	31	35	38	60	62

## 4.9 Dimensions

The dimensions of the product are given in the technical data sheets.

## 5 Transport and storage

### 5.1 General

---

- a) After receiving the delivery, check the product for transport damage.
  - b) If transport damage is found, the manufacturer and the transport company must be notified immediately. The product must then be replaced or repaired.
  - c) Dispose of packaging materials and used parts according to local regulations.
- 

### 5.2 Transport



#### **⚠ WARNING**

##### **Falling or toppling loads**

Risk of injury during transport of large and heavy loads.

- a) Use only suitable means of transport and lifting gear with sufficient load-bearing capacity.
  - b) Attach lifting gear only to suitable places on the load.
  - c) Attach the lifting gear so that it cannot slip.
  - d) Note the centre of gravity of the load.
  - e) Avoid sudden, jerky movements, impacts and strong vibrations during transport.
  - f) Do not step under overhead loads, do not work under overhead loads.
- 



#### **NOTICE**

Eyebolts can be screwed into the thread of the flanged connections to transport the product.

---

### 5.3 Storage

The product's function is tested in the factory with mineral hydraulic oil. The connections are then closed. The remaining residual oil preserves the internal parts for up to 6 months.

Bright metallic external parts are also protected against corrosion by suitable preservation measures for up to 6 months.

During storage, ensure a dry, dust-free and low-vibration environment. The product must be protected from weather, moisture and large temperature fluctuations. Comply with the recommended storage conditions.

Below the permissible ambient temperature  $\vartheta_U$ , elastomer seals lose their elasticity and mechanical loading capacity, as the temperature is below the glass transition temperature. This process is reversible. Avoid the application of force on the product during storage below the permissible ambient temperature  $\vartheta_U$ .

Products with EPDM seals are not mineral oil resistant and their function is not tested. The internal parts are not preserved. If the product is not put into operation immediately, all surfaces exposed to corrosion must be protected by suitable preservation measures. The same applies to products that are not tested for other reasons.

In case of storage for a longer period (> 6 months), all surfaces exposed to corrosion must be retreated with suitable preservatives.

If high humidity or an aggressive atmosphere is to be expected, additional suitable corrosion prevention measures must be taken.



## NOTICE

Storage in corrosion protection bags (VCI) for maximum 6 months.

## ⚠ ATTENTION

### Corrosion/chemical attack

Improper storage can make the product unusable.

- a) Use suitable preservation measures to protect exposed surfaces.
- b) Comply with the recommended storage conditions.

## 5.4 Storage conditions



## TIP

### Recommended storage conditions

- a) Storage temperature: 5 °C – 25 °C
- b) Relative humidity: < 70 %
- c) Protect elastomer parts from light, particularly direct sunlight.
- d) Protect elastomer parts from oxygen and ozone.
- e) Note the maximum storage period of elastomer parts:
  - ⇒ 5 years: AU (polyurethane rubber)
  - ⇒ 7 years: NBR, HNBR, CR
  - ⇒ 10 years: EPM, EPDM, FEP/PFTE, FEPM, FKM, FFKM, VMQ, FVMQ

## 5.5 Special hazards



### **DANGER**

#### **Strong magnetic field**

Risk to life for people with active implanted cardiac devices

- a) Maintain a safety distance of at least 2 m from unmounted components of the magnetic coupling.
- b) Maintain a safety distance of at least 0.5 m from couplings to be installed with axially aligned magnetic rotors and surrounding bell housing (pump support).



### **WARNING**

#### **Strong magnetic field**

Risk of injury caused by uncontrolled mutual attraction between magnetic or magnetisable parts.

- a) When performing any work, bear in mind the magnetic forces which occur, especially within 0.5 m of the magnetic coupling.

### **ATTENTION**

#### **Powerful magnetic field**

Magnetic data carriers (discs, credit cards, etc.) can be damaged or erased by magnetic fields.

- a) Maintain a minimum clearance of 1 m to the magnetic field.

## 6 Installation

### 6.1 Safety instructions for installation



#### **⚠ DANGER**

##### **Hazardous fluids**

Danger to life when handling hazardous fluids

- a) Comply with the safety data sheets and regulations on handling the hazardous fluids.
- b) Collect and dispose of hazardous fluids so that no hazard is created for persons or the environment.



#### **⚠ DANGER**

##### **Rotating parts**

Risk to life due to entanglement or winding of parts of the body, hair or clothing items.

- a) Before carrying out any work, disconnect any drives and actuators from the power supply or depressurise them.
- b) Safely prevent restarting during the work.



#### **⚠ DANGER**

##### **Rotating parts**

Risk to life due to entanglement or winding of parts of the body, hair or clothing items.

- a) Take measures to prevent accidental touching of rotating parts.



#### **⚠ WARNING**

##### **Rotating parts**

Risk of injury caused by ejected parts

- a) Enclose rotating parts so that in the event of fracture or malfunction, there is no risk caused by ejected parts.



#### **⚠ WARNING**

##### **Exposed gears**

Gearwheels can trap and crush fingers and hands.

- a) Do not engage gearwheels.



**⚠ WARNING****Failure of pressure bearing parts due to overload**

Risk of injury from flying parts.

Risk of injury due to splashing fluids.

- a) Before carrying out any work, depressurise the product and all connection pipes.
- b) Securely prevent the pressure from being restored during work.

**⚠ WARNING****Failure of pressure bearing parts due to overload**

Risk of injury from flying parts.

Risk of injury due to splashing fluids.

- a) Use only connections and lines approved for the expected pressure range.
- b) Securely prevent the permissible pressures from being exceeded, e.g. by using pressure relief valves or bursting discs.
- c) Pipelines must be designed in such a way that no tension e.g. caused by changes in length due to fluctuations in temperature can be transferred to the product.

## 6.1.1 Special hazards

**⚠ DANGER****Strong magnetic field**

Risk to life for people with active implanted cardiac devices

- a) Maintain a safety distance of at least 2 m from unmounted components of the magnetic coupling.
- b) Maintain a safety distance of at least 0.5 m from couplings to be installed with axially aligned magnetic rotors and surrounding bell housing (pump support).

**⚠ WARNING****Strong magnetic field**

Risk of injury caused by uncontrolled mutual attraction between magnetic or magnetisable parts.

- a) When performing any work, bear in mind the magnetic forces which occur, especially within 0.5 m of the magnetic coupling.

 **ATTENTION****Powerful magnetic field**

Magnetic data carriers (discs, credit cards, etc.) can be damaged or erased by magnetic fields.

- a) Maintain a minimum clearance of 1 m to the magnetic field.

## 6.2 Noise reduction

**TIP****Measures to reduce noise**

- a) Use of suction and pressure hoses.
- b) Use of pump supports with high damping properties (plastic or grey cast iron)
- c) Use of damping rings and damping rails to isolate structure-borne sound.

## 6.3 Mechanical installation

### 6.3.1 Preparation

- a) Check the product for transport damage and contamination.
- b) Check the product for smooth and easy movement.
- c) Remove any preservative present.
- d) Clean all lines.
  - ⇒ Only use cleaning agents that are compatible with the materials used.
  - ⇒ Do not use cleaning wool.
- e) Compare the environmental and ambient conditions at the place of use with the permissible conditions.
  - ⇒ Make sure that the foundation is sufficiently stable and level.
  - ⇒ Expose the product only to low vibrations, see IEC 60034-14.
  - ⇒ Ensure sufficient accessibility for maintenance and repair.
- f) Position the product and secure it against slipping.
  - ⇒ Comply with the manufacturer's instructions.
  - ⇒ Do not use any sealing materials such as hemp, Teflon tape or putty.
- g) Remove existing protective plugs.

### 6.3.2 Gear pump for magnetic coupling

The prerequisite for trouble-free operation is suitable load transmission between the gear pump and the drive.

By default, a permanent magnetic coupling is used for this.

- a) Preassemble the coupling parts as described by the manufacturer.
- b) Position the pump and drive relative to each other.
  - ⇒ Note the allowable installed position.
  - ⇒ Note the allowable direction of rotation.
- c) Tighten the fastening screws to the specified torque.

Tightening torques [Nm]							
Thread size	M6	M8	M10	M12	M16	M20	M24
Counter-thread Aluminium	4.6	11	22	39	95	184	315
Counter-thread Cast iron / Steel	10	25	49	85	210	425	730

Screws/Nuts with min. strength class 8.8/8



#### NOTICE

- a) Comply with the allowable displacement values of the coupling.
- b) Prevent stressing of the product.
- c) Make sure the fastening screws have sufficient depth of engagement.



#### NOTICE

- a) Make sure no foreign bodies can get into the device.
- b) Mount the specified monitoring units as per the manufacturer's instructions.



#### TIP

For the assembly we recommend to have the data sheet of the magnetic coupling with you. Specifications entered in the dimensional drawing have to be primarily observed.



#### TIP

For assembly, the coupling halves can be heated to approx. 80 °C and pushed onto the shaft ends while warm.



### ⚠ CAUTION

#### Hot surfaces

Burns of the skin on contact.

- a) Wear protective gloves at temperatures  $\geq 48^{\circ}\text{C}$ .



### ⚠ WARNING

#### Strong magnetic forces

Danger of crushing due to sudden tightening of the magnets of the internal and external rotor.

## 6.4 Connection lines

### 6.4.1 General



### ⚠ WARNING

#### Failure of pressure bearing parts due to overload

Risk of injury from flying parts.

Risk of injury due to splashing fluids.

- a) Use only connections and lines approved for the expected pressure range.
- b) Securely prevent the permissible pressures from being exceeded, e.g. by using pressure relief valves or bursting discs.
- c) Pipelines must be designed in such a way that no tension e.g. caused by changes in length due to fluctuations in temperature can be transferred to the product.



### NOTICE

#### Additional connections

- a) Provide measurement connections for pressure and temperature as near as possible on the device.
- b) If necessary, provide an option for filling and draining the device and line system.
- c) If necessary, provide an option for venting the device and line system.

## 6.4.2 Suction line

A suction line that is not optimally designed can lead to increased noise emissions, cavitation and even a reduction in the capacity (due to less filling of the pump).

When designing the lines, bear in mind the following points:

- Lay the suction line as short and straight as possible.
- Specify the nominal size of the suction line so that the operating pressure on the suction side is not less than the permissible operating pressure  $p_{e \text{ min}}$ .
- Avoid large suction heights.
- Avoid additional pressure loss through line resistances such as fittings, screwed connections, formed parts or suction filters/suction baskets. Ensure that all technically required suction filters/suction baskets are appropriately dimensioned.
- Pay attention to sufficient distance of the suction opening from the floor and walls of the media tank.
- Make sure that the suction opening is below the lowest fluid level in any operating situation.
- When using hoses, make sure that they have sufficient stability so that they do not become constricted by the suction effect.
- Note the recommended flow velocity in the suction line (max. 1.5 m/s).

### Suction line at vacuum operation

If medium is to be drawn from a tank under vacuum, the pump must be positioned approx. 1 m below the tank. The suction line must be laid straight and without any resistances.

The tank may be subjected to vacuum only then when the pipework and the pump have been filled with liquid. Only pumps suitable for vacuum operation may be used for this purpose.

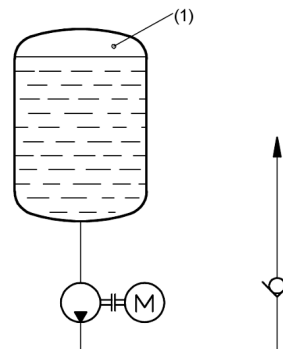

## NOTICE

### Cavitation damage

Pressure below the permissible suction side pressure causes cavitation

- a) Design the suction line so that the pressure that sets in during operation is always higher on the suction side than the vapour pressure of the pumped medium. At the same time, make sure that the device is installed above sea level.
- b) If fluids contain water, install the device below the fluid level and limit the operating temperature to 50 °C and the speed to 1500 1/min.

### Prevention of suction problems

If there is a possibility of the suction line running dry while the pump is at a standstill, laying the suction line as a U-trap is a way of avoiding suction problems. This way, the pump will remain permanently filled after initial commissioning.

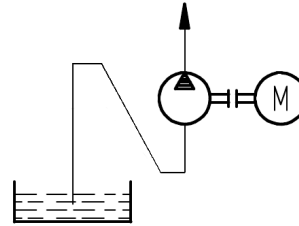

In case of longer suction lines that can run empty during the standstill, it is useful to insert a foot valve or a non-return valve. These must have been designed for use in suction lines and should offer as low a flow resistance as possible.

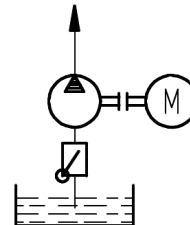

When operating a pump that has to pump via a non-return valve into a pressurized circuit (e.g. reserve pump in a lubricant circuit), intake difficulties can occur if the suction line is filled with air. In this case the pressure line must be vented directly upstream of the non-return valve. If a venting nozzle is not inserted, the volume of the pressure line between the pump and non-return valve must be at least 75% of the suction line volume.

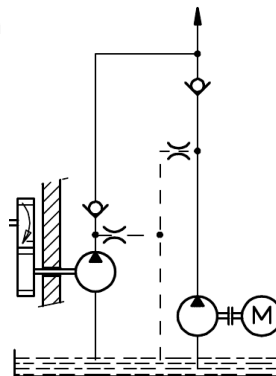

## 6.4.3 Pressure pipe

When designing the lines, bear in mind the following points:

- Choose the nominal size of the pressure line so that the maximum permissible pressures are not exceeded.
- If necessary, provide a venting nozzle to prevent suction problems.

## 6.4.4 Connection line installation

- a) Clean all lines.
  - ⇒ Do not use cleaning wool.
  - ⇒ Pickle and rinse welded pipes.
- b) Remove existing protective plugs.
- c) Install the lines.
  - ⇒ Comply with the manufacturer's instructions.
  - ⇒ Do not use any sealing materials such as hemp, Teflon tape or putty.



**TIP**

Location of the device connections: **Direction of rotation and discharge** [▶ 18]

## 6.5 Change of the direction of rotation

Depending on the design, a change in direction of rotation is possible.

The modification required is normally carried out by the manufacturer and should only be carried out by the customer in exceptional cases. Please consult the manufacturer for this purpose.



**NOTICE**

Design variants with internal rinsing do not allow for the rotation direction to be reversed. Unit must be replaced.

### 6.5.1 Gear pump without noise optimisation

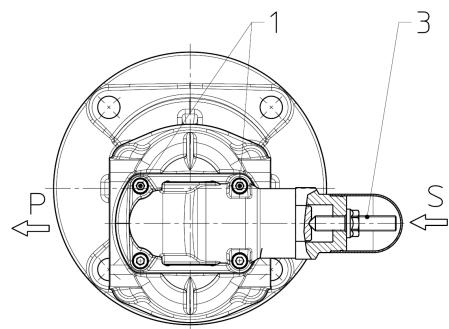
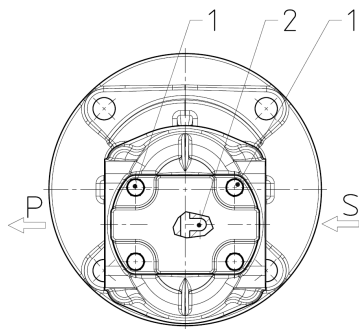

S = Suction connection  
P = Pressure connection

1 Fastening screws  
2 Leak oil hole  
3 Adjustment screw

To change the direction of rotation of the gear pump, turn the end cover or the pressure relief valve 180°.

- a) Undo the fastening screws.
- b) Remove the end cover or the pressure relief valve respectively from the pump housing and put it back on rotated by 180°.
- c) Tighten the fastening screws with the stated torque.

Zahnradpumpe	Tightening torques [Nm] fastening screws end cover
KF 3	25
KF 4	
KF 5	49
KF 6	



## NOTICE

**When checking, pay attention to the following points:**

- a) Gear pumps without pressure relief valve must have the leak oil hole in the end cover on the inlet side.
- b) Gear pumps with pressure relief valve must have their pressure relief valve adjusting screw point toward the pump's suction side.



## 7 Commissioning

### 7.1 Safety instructions for start-up



#### **⚠ DANGER**

##### **Hazardous fluids**

Danger to life when handling hazardous fluids

- a) Comply with the safety data sheets and regulations on handling the hazardous fluids.
- b) Collect and dispose of hazardous fluids so that no hazard is created for persons or the environment.



#### **⚠ WARNING**

##### **Failure of pressure bearing parts due to overload**

Risk of injury caused by flying parts.

Risk of injury caused by splashing fluids.

- a) Do not operate the product with shut-off devices closed.
- b) Do not operate the production in the wrong rotational direction.



#### **⚠ CAUTION**

##### **Hot surfaces**

Burns of the skin on contact.

- a) Wear protective gloves at temperatures  $\geq 48^{\circ}\text{C}$ .

#### 7.1.1 Special hazards



#### **⚠ DANGER**

##### **Strong magnetic field**

Risk to life for people with active implanted cardiac devices

- a) Maintain a safety distance of at least 2 m from unmounted components of the magnetic coupling.
- b) Maintain a safety distance of at least 0.5 m from couplings to be installed with axially aligned magnetic rotors and surrounding bell housing (pump support).



### ⚠ WARNING

#### Strong magnetic field

Risk of injury caused by uncontrolled mutual attraction between magnetic or magnetisable parts.

- a) When performing any work, bear in mind the magnetic forces which occur, especially within 0.5 m of the magnetic coupling.

### ⚠ ATTENTION

#### Powerful magnetic field

Magnetic data carriers (discs, credit cards, etc.) can be damaged or erased by magnetic fields.

- a) Maintain a minimum clearance of 1 m to the magnetic field.

## 7.2 Preparation

- a) Before starting the system make sure that a sufficient quantity of the service fluid is extant to avoid dry running. This must be taken into account especially with large line volumes.
- b) Check all fastening screws on the product.
- c) Fill the pump and the suction line with medium.

## 7.3 Pressure valve setting

The valves are set to the rated pressure of the respective pressure stage in the factory. Set pressures deviating from this are given on the type plate.

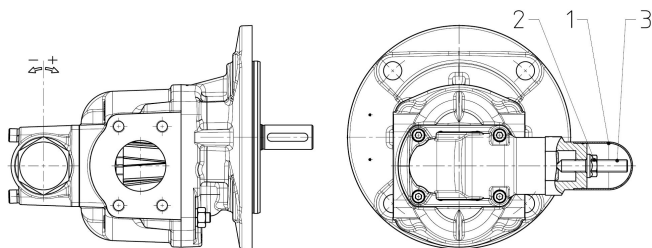

- |   |                          |   |                  |
|---|--------------------------|---|------------------|
| - | response pressure lower  | 1 | Cover            |
| + | response pressure higher | 2 | Collar nut       |
|   |                          | 3 | Adjustment screw |

- a) Remove cover.
- b) Loosen the hexagon nut.
- c) Use the adjusting screw to set the set pressure.
- d) Secure the adjusting screw with a hexagon nut.
- e) Mount cover.



## ⚠ WARNING

### Failure of pressure bearing parts due to overload

Risk of injury from flying parts.

Risk of injury caused by splashing fluids.

- a) Note the permissible pressure setting range of the valve.
- b) Check the pressure setting (the valve must not block).

## 7.3.1 Pressure relief valve

Directly attached series D pressure relief valves are used only to protect the gear pump and may only operate for a short time.



## NOTICE

### Failure of the gear pump

Longer operation of the valve can cause the gear pump to overheat.

- a) Operate the valve for a short time only.

## 7.4 Additional commissioning

- a) Open existing shut-off elements in front of and behind the product.
- b) Set pressure relief valves installed in the system to the lowest opening pressure.
- c) Start the product without pressure load or with low pressure (jog mode).
  - ⇒ A flow should have developed after 30 s at the latest.
- d) Run the product pressureless or at low pressure for a few minutes.
- e) Vent the system at the highest possible point.
- f) Gradually increase the pressure up to the required operating pressure.
- g) Operate the system until the final operating condition is reached.
- h) Check the operating data.
  - ⇒ **Maintenance table [▶ 50]**
- i) Document the operating data of the initial commissioning for later comparison.
- j) Check the level of the operating medium in the system.
- k) Check the level of the seal fluid (if present).
- l) Check the product for leaks.
- m) Check all fittings for leaks and retighten if necessary.

## 8 Removal

### 8.1 Safety instructions for disassembly



#### **⚠ DANGER**

##### **Hazardous fluids**

Danger to life when handling hazardous fluids

- a) Comply with the safety data sheets and regulations on handling the hazardous fluids.
- b) Collect and dispose of hazardous fluids so that no hazard is created for persons or the environment.



#### **⚠ DANGER**

##### **Rotating parts**

Risk to life due to entanglement or winding of parts of the body, hair or clothing items.

- a) Before carrying out any work, disconnect any drives and actuators from the power supply or depressurise them.
- b) Safely prevent restarting during the work.



#### **⚠ WARNING**

##### **Exposed gears**

Gearwheels can trap and crush fingers and hands.

- a) Do not engage gearwheels.



#### **⚠ WARNING**

##### **Failure of pressure bearing parts due to overload**

Risk of injury from flying parts.

Risk of injury due to splashing fluids.

- a) Before carrying out any work, depressurise the product and all connection pipes.
- b) Securely prevent the pressure from being restored during work.



#### **⚠ CAUTION**

##### **Hot surfaces**

Burns of the skin on contact.

- a) At temperatures  $\geq 48$  °C, allow the product to cool first.

**⚠ ATTENTION****Blocking of the product due to curing media**

Curing media can mechanically block the product and make it unusable.

- a) Clean the product immediately after operation with curing media.

### 8.1.1 Special hazards

**⚠ DANGER****Strong magnetic field**

Risk to life for people with active implanted cardiac devices

- a) Maintain a safety distance of at least 2 m from unmounted components of the magnetic coupling.
- b) Maintain a safety distance of at least 0.5 m from couplings to be installed with axially aligned magnetic rotors and surrounding bell housing (pump support).

**⚠ WARNING****Strong magnetic field**

Risk of injury caused by uncontrolled mutual attraction between magnetic or magnetisable parts.

- a) When performing any work, bear in mind the magnetic forces which occur, especially within 0.5 m of the magnetic coupling.

**⚠ ATTENTION****Powerful magnetic field**

Magnetic data carriers (discs, credit cards, etc.) can be damaged or erased by magnetic fields.

- a) Maintain a minimum clearance of 1 m to the magnetic field.

## 8.2 Dismantling

---

- a) Depressurise and de-energise the system.
  - b) Close existing shut-off elements in front of and behind the product.
  - c) Open existing drain elements and undo connection lines. Collect and dispose of leaking media so that no hazard is created for persons or the environment.
  - d) Dismantle the product.
  - e) Clean the product.
  - f) Seal the process connections and lines to prevent the ingress of dirt.
- 



### NOTICE

The concrete procedure for cleaning depends on the media being used.

- a) See the safety data sheet of the media in use.
-

## 9 Maintenance

### 9.1 Safety instructions for maintenance



#### **⚠ DANGER**

##### **Hazardous fluids**

Danger to life when handling hazardous fluids

- a) Comply with the safety data sheets and regulations on handling the hazardous fluids.
- b) Collect and dispose of hazardous fluids so that no hazard is created for persons or the environment.



#### **⚠ DANGER**

##### **Rotating parts**

Risk to life due to entanglement or winding of parts of the body, hair or clothing items.

- a) Before carrying out any work, disconnect any drives and actuators from the power supply or depressurise them.
- b) Safely prevent restarting during the work.



#### **⚠ WARNING**

##### **Failure of pressure bearing parts due to overload**

Risk of injury from flying parts.

Risk of injury due to splashing fluids.

- a) Before carrying out any work, depressurise the product and all connection pipes.
- b) Securely prevent the pressure from being restored during work.



#### **⚠ CAUTION**

##### **Hot surfaces**

Burns of the skin on contact.

- a) At temperatures  $\geq 48$  °C, allow the product to cool first.

## 9.1.1 Special hazards



### **DANGER**

#### **Strong magnetic field**

Risk to life for people with active implanted cardiac devices

- a) Maintain a safety distance of at least 2 m from unmounted components of the magnetic coupling.
- b) Maintain a safety distance of at least 0.5 m from couplings to be installed with axially aligned magnetic rotors and surrounding bell housing (pump support).



### **WARNING**

#### **Strong magnetic field**

Risk of injury caused by uncontrolled mutual attraction between magnetic or magnetisable parts.

- a) When performing any work, bear in mind the magnetic forces which occur, especially within 0.5 m of the magnetic coupling.

### **ATTENTION**

#### **Powerful magnetic field**

Magnetic data carriers (discs, credit cards, etc.) can be damaged or erased by magnetic fields.

- a) Maintain a minimum clearance of 1 m to the magnetic field.



## 9.2 Maintenance work



### TIP

#### Checking and documentation of the operating data

Regular checking and documentation of all operating data helps to detect faults at an early stage.

- Perform the maintenance work according to specifications.
- Replace defective or worn components.
- If necessary, request spare parts lists and assembly drawings from the manufacturer.
- Document the type and scope of the maintenance work along with the operating data.
- Compare the operating data with the values of the initial commissioning.  
In case of large deviations (> 10 %), determine the cause.
- Dispose of packaging materials and used parts according to local regulations.



### NOTICE

#### Protective devices and notes

After maintenance and/or repair, reattach all protective devices and notices removed in the process to their original position.

## 9.3 Maintenance instructions

The following information provides recommendations for maintenance work and maintenance intervals for the product in use.

Depending on the actual loads occurring during operation, the type, scope and interval of the maintenance work may deviate from the recommendations. A mandatory maintenance plan must be drawn up by the installer/operating company.



### TIP

In the course of preventive maintenance, it is advisable to replace wearing parts before the wear limit is reached.

With the appropriate know-how and sufficient equipment, the repair can also be carried out by the installer/operating company.

If necessary, request spare parts lists and assembly drawings from the manufacturer.

Please consult the manufacturer for this purpose.



### NOTICE

#### Warranty

Any warranty will be void if not executed properly.

## 9.4 Maintenance table

### 9.4.1 Maintenance table

		Firstly:after max. 24 h	Daily	3000 Operating hours	6000 Operating hours	As required	Additional in-formation
9.4.2	Check the rate of flow	2					
9.4.3	Check the operating pressure	2					
9.4.4	Check the media temperature	2					
9.4.5	Check the device temperature	2					
9.4.6	Check the function of the add-on valve	2					
9.4.7	Check the equipotential bonding	2					
9.4.8	Check the condition of the operating fluid	2					
9.4.9	Auditory check Unusual noises		1				
9.4.10	Cleaning		1				
9.4.11	Visual inspection for leakage		1				
9.4.12	Visual check of seal fluid level		2				
9.4.2	Check the rate of flow			2			
9.4.3	Check the operating pressure			2			
9.4.4	Check the media temperature			2			
9.4.5	Check the device temperature			2			
9.4.6	Check the function of the add-on valve			2			
9.4.7	Check the equipotential bonding			2			
9.4.8	Check the condition of the operating fluid			2			
9.4.13	Visual check of the gearbox condition				3		
9.4.14	Visual check of the condition of housing parts				3		
9.4.15	Visual check of the condition of the plain bearings				3		
9.4.16	Visual check of the condition shaft seal				3		
9.4.17	Visual check of the condition of the out-board bearing				3		
9.4.18	Replacing the outboard bearing					3	
9.4.19	Replacing the plain bearings					3	
9.4.20	Replacing the shaft seal					3	
9.4.21	Replacing other seals					3	

1 - 0,1 h; 2 - 0,2 h; 3 - 0,75 h

## 9.4.2 Check the rate of flow

The rate of flow is measured via the volumetric flow meter.

The values are displayed by the built-in controller in the electrical control system.

- If there is no discharge flow, check the individual components of the product.
- Comply with the product-specific data sheets/operating instructions.

## 9.4.3 Check the operating pressure

The operating pressure is indicated by the pressure gauges.

- If there is no operating pressure, check the individual components of the product.
- Comply with the product-specific data sheets/operating instructions.

## 9.4.4 Check the media temperature

The media temperature is measured through the temperature sensor.

The values are displayed by the built-in controller in the electrical control system.

- If the media temperature is too high or too low, check the product components.
- Comply with the product-specific data sheets/operating instructions.

## 9.4.5 Check the device temperature

Measure the surface temperature in the area of the bearing.

## 9.4.6 Check the function of the add-on valve

Add-on valves must be operated at regular intervals. This is necessary to ensure their faultless function.

## 9.4.7 Check the equipotential bonding

Check the equipotential bonding for tight fit and proper functioning.

## 9.4.8 Check the condition of the operating fluid

Pay attention to colour (dark colouring), odour and milky turbidity.

- Replace operating fluid if necessary.

## 9.4.9 Auditory check Unusual noises

In this case, attention must be paid to increased noise or uneven operation (pump unit).

- In case of unusual noises, examine the individual components of the product and line fixings and check the operating medium for foaming.
- Comply with the product-specific data sheets/operating instructions.

## 9.4.10 Cleaning

Remove dust deposits and dirt with a damp, clean cloth.

### 9.4.11 Visual inspection for leakage

Care must be taken here to ensure that there is no leakage from the connections.

- In the event of leaks in the connections, the glands must be tightened and, if necessary, the seals replaced.

### 9.4.12 Visual check of seal fluid level

Pay attention to the level of the seal fluid. If necessary, top up the seal fluid.

If there is no automatic monitoring, the filling level must be checked at least before each shift begins.

If the level drops unusually quickly within a short time, it is possible that the outer or inner shaft seal is leaking.

If the level increases, it is likely that the inner shaft seal is leaking and barrier medium is mixed with the pumped medium.

- Stop plant operation immediately in both cases.

### 9.4.13 Visual check of the gearbox condition

The driving shaft pinion and driven shaft pinion are wearing parts. In case of excessive wear, the parts or the pump must be replaced.

Important places to check are the surfaces opposite the shaft seal and bearing bushes, end faces of the driving shaft pinion and driven shaft pinion as well as the tooth flanks.

### 9.4.14 Visual check of the condition of housing parts

Important places to check are the end faces of the impeller chamber.

### 9.4.15 Visual check of the condition of the plain bearings

The plain bearings are wearing parts. In case of excessive wear, the parts or the pump must be replaced.

In case of multilayer plain bearings, the wear limit is reached if the bronze layer of the bearing is 50-70 % exposed.

When loaded on the suction side, the driving shaft pinion and driven shaft pinion are supported in the bearings so that wear is identified there first.

### 9.4.16 Visual check of the condition shaft seal

Pay attention to leak quantities and impermissible temperature increases.

- Small leaked quantities are indispensable for the function of the seal.
- In case of excessive leaked quantities or impermissible temperature increase, the pump must be shut down immediately. Replace the seal.

### 9.4.17 Visual check of the condition of the outboard bearing

The outboard bearing is a wearing part.

The life of the bearing primarily depends on the operating conditions.

The bearing should therefore be checked for damage after 4000 h at the latest. In the event of unacceptable wear, the bearing must be replaced.

Onsetting wear or pending failure can become noticeable due to increased heating of the bearing, increased power consumption, irregular running or even noise emissions.

### 9.4.18 Replacing the outboard bearing

With the appropriate know-how and adequate equipment, the repair can also be carried out by the installer/operating company.

To this end, if necessary, request spare parts and assembly drawings from the manufacturer.

Only use spare parts approved by the manufacturer.

### 9.4.19 Replacing the plain bearings

These are replaced only by the manufacturer.

Contact the manufacturer.

### 9.4.20 Replacing the shaft seal

With the appropriate know-how and adequate equipment, the repair can also be carried out by the installer/operating company.

To this end, if necessary, request spare parts and assembly drawings from the manufacturer.

Only use spare parts approved by the manufacturer.

### 9.4.21 Replacing other seals

With the appropriate know-how and adequate equipment, the repair can also be carried out by the installer/operating company.

To this end, if necessary, request spare parts and assembly drawings from the manufacturer.

Only use spare parts approved by the manufacturer.

# 10 Repair

## 10.1 Safety instructions for repairs



### **⚠ DANGER**

#### **Hazardous fluids**

Danger to life when handling hazardous fluids

- a) Comply with the safety data sheets and regulations on handling the hazardous fluids.
- b) Collect and dispose of hazardous fluids so that no hazard is created for persons or the environment.



### **⚠ DANGER**

#### **Rotating parts**

Risk to life due to entanglement or winding of parts of the body, hair or clothing items.

- a) Before carrying out any work, disconnect any drives and actuators from the power supply or depressurise them.
- b) Safely prevent restarting during the work.



### **⚠ WARNING**

#### **Failure of pressure bearing parts due to overload**

Risk of injury from flying parts.

Risk of injury due to splashing fluids.

- a) Before carrying out any work, depressurise the product and all connection pipes.
- b) Securely prevent the pressure from being restored during work.



### **⚠ CAUTION**

#### **Hot surfaces**

Burns of the skin on contact.

- a) At temperatures  $\geq 48$  °C, allow the product to cool first.

## 10.1.1 Special hazards



### **DANGER**

#### **Strong magnetic field**

Risk to life for people with active implanted cardiac devices

- a) Maintain a safety distance of at least 2 m from unmounted components of the magnetic coupling.
- b) Maintain a safety distance of at least 0.5 m from couplings to be installed with axially aligned magnetic rotors and surrounding bell housing (pump support).



### **WARNING**

#### **Strong magnetic field**

Risk of injury caused by uncontrolled mutual attraction between magnetic or magnetisable parts.

- a) When performing any work, bear in mind the magnetic forces which occur, especially within 0.5 m of the magnetic coupling.

### **ATTENTION**

#### **Powerful magnetic field**

Magnetic data carriers (discs, credit cards, etc.) can be damaged or erased by magnetic fields.

- a) Maintain a minimum clearance of 1 m to the magnetic field.

## 10.2 General

Corrective maintenance includes:

1. Troubleshooting  
Finding damage, determining and localising the cause of the damage.
2. Damage repair  
Removing the primary causes and replacing or repairing defective components. Repairs are generally carried out by the manufacturer.

### Repair by the manufacturer

Before returning the product, fill out the return form. The form can be filled out online and is available to download as a pdf file or can be requested from the manufacturer.



### NOTICE

#### Device contains hazardous substances

If the device has been operated with hazardous fluids it must be cleaned before it is returned. If this is not possible, the safety data sheet of the hazardous material must be provided in advance.

#### Repair by the installer/operating company

With the appropriate know-how and sufficient equipment, the repair can also be carried out by the installer/operating company. Please consult the manufacturer for this purpose.

- a) If necessary, request spare parts lists and assembly drawings from the manufacturer.
- b) Only use spare parts approved by the manufacturer.
- c) Dispose of packaging materials and used parts according to local regulations.



### NOTICE

#### Warranty

Any warranty will be void if not executed properly.



### NOTICE

#### Protective devices and notes

After maintenance and/or repair, reattach all protective devices and notices removed in the process to their original position.



### 10.3 Fault table

<b>Fault</b>	<b>Potential causes</b>	<b>Possible measures</b>
<b>Increased noise</b>		
Pump cavitation	Excessive negative pressure (not complete filling of the pump)	Check suction line design Use noise-optimised pump
	Suction line clogged	Clean the suction line
	Suction filter plugged or too small	Clean suction filter or use a larger filter
		Replace filter element
	Suction basket plugged or too small	Clean intake strainer or dimension larger
	Fluid temperature too low	Adjust the temperature of medium
Foaming or air in media	Pump does not suck	Check the oil level in the tank
		Check suction line
		Check the shaft seal
	Shaft seal defective	Replace seals
	Suction connection leaking	Tighten or replace the screw connections
		Replace seals
	System not vented	Vent the system
Return line ends above the fluid level	Extend return line	
Heavy foaming in the system, e.g. in gears	Use noise-optimised pump	
Mechanical vibrations	Incorrectly aligned and/or loose coupling	Correct the alignment of the coupling and secure the coupling halves
	Incorrectly and/or insufficient line fastening	Fixate lines with suitable fastening material (e.g. pipe clamps)
	Wobbling pressure relief valve	Increase valve opening pressure
	Not a noise-reducing setup	Use dampers
<b>Pump does not suck</b>		
	Dry run	Fill pump and the suction line with medium
	Minimum filling level in the reservoir tank undercut	Refill media
	Wrong direction of rotation	Correct the direction of rotation
	Throttled/closed shut-off element in the suction line	Open the shut-off element
	Suction line clogged	Clean the suction line

<b>Pump does not suck</b>		
	The air in the suction line cannot be compressed in the pressure line	Reduce the start-up pressure
		Vent the pressure line
		Increase volume of the pressure line
	Speed of the pump is too low	Check the pump design
		During frequency inverter operation: Check the operation/line frequency
	Geodetic suction head too high	Check installation location
Provide pre-filling pump		
<b>Insufficient pressure</b>		
<b>Insufficient pumping flow rate</b>		
	Excessive negative pressure (not complete filling of the pump)	Check suction line design
	Too high media viscosity	Provide pre-filling pump
	Speed of the pump is too low	Check the pump design
		During frequency inverter operation: Check the operation/line frequency
	Throttled/closed shut-off element in the suction line	Open the shut-off element
	Suction line clogged	Clean the suction line
	Suction filter plugged or too small	Clean suction filter or use a larger filter
		Replace filter element
	Suction basket plugged or too small	Clean intake strainer or dimension larger
	Constant triggering of pressure relief valve (if existing)	Increase valve opening pressure
	Pump does not suck	Check the oil level in the tank
		Check suction line
Check the shaft seal		
Wear	Replace the device	
<b>Excessive operating temperature</b>		
	Cooling and heat dissipation insufficient	Increase the cooling capacity
	Not sufficient oil in the system	Check the container layout
	Excess fluid is being delivered into the supply tank via pressure relief valve under load	Check the pump design

<b>Impermissible pump heating</b>		
	Constant triggering of pressure relief valve (if existing)	Increase valve opening pressure
	Pressure too high in association with a media viscosity that is too low	Check the system design
	Speed too fast in connection with media viscosity that is too high	Check the system design
	Gland lid overtightened (for gland seal)	Unscrew gland lid and readjust leakage
	Suction pressure too high	Reduce the pressure
	Wear	Replace the device
<b>Leakage</b>		
Seal failure	Lack of maintenance	Comply with maintenance inter-vals
		Replace seals
	Mechanical damage	Replace seals
	Thermal overload	Check operating data
		Replace seals
	Pressure too high	Check operating data
		Replace seals
	Gas content in media too high	Check operating data
		Replace seals
	Corrosion/chemical degradation	Check material compatibility
Replace seals		
Wrong direction of rotation	Correct the direction of rotation	
	Replace seals	
Contaminated medium	Provide filtration	
	Replace seals	
Gland lid not sufficiently tightened (for gland seal)	Retighten gland lid	
Loose screw connection	Tighten or replace the screw connections	
<b>Magnetic coupling</b>		
Change in operating noise and/or the occurrence of vibrations	Alignment error	See Operating/installation instructions for magnetic coupling: Failures, causes and clearance
	Breakdown of the magnetic forces	
	Damaged exterior magnets due to assembly error (external rotor striking the containment shroud)	

<b>Magnetic coupling</b>		
Repeated breakdown of the magnetic forces	Operating parameters do not match the coupling power	See Operating/installation instructions for magnetic coupling: Failures, causes and clearance
	Excessive operating temperature	
	Abrasive particles in the pumping medium that block the pump	
Pump does not suck The torque is not transmitted	The magnets of the interior and exterior rotors are not placed flush above one another	Check the assembly dimensions in accordance with the assembly drawing
<b>Motor protection switch tripped</b>		
	Driving power too low	Check the drive design
	Motor incorrectly connected	Check motor connection
	Phase failure	Check feed/supply
	Current consumption too high	Check operating data
		Check direction of rotation
Motor circuit breaker incorrectly designed	Check operating data	
Consult the manufacturer in the event of unidentifiable faults		