

# D.0032770002

## Operating instructions (Translation)



High pressure gear pump KP 2/. .../434, KP 3/. .../434, KP 5/. .../434

88032770002-02

Englisch

2016-07-21

**KRACHT**

# Table of Content

<b>1</b>	<b>General</b>	<b>4</b>
1.1	About the documentation	4
1.2	Manufacturer´s address	4
1.3	Applicable documents	4
1.4	Symbolism	5
<b>2</b>	<b>Safety</b>	<b>6</b>
2.1	Intended use	6
2.2	Personnel qualification and training	6
2.3	Basic safety instructions	6
2.4	Basic hazards	7
<b>3</b>	<b>Device description</b>	<b>9</b>
3.1	Functional principle	9
3.2	Basic construction	11
3.2.1	KP 2/. + KP 3/. ... /434	11
3.2.2	KP 5/. ... /434	12
3.3	Rotation and delivery direction	13
3.4	Quench	13
3.5	Type key	14
<b>4</b>	<b>Technical data</b>	<b>16</b>
4.1	General	16
4.2	Overview nominal sizes	16
4.3	Viscosity - Rotation speed assignment	17
4.3.1	Max. speed depending on the viscosity	17
4.3.2	Min. speed depending on the viscosity and pressure	17
4.4	Material data	18
4.5	Permissible pressure range	19
4.5.1	Operating pressure of suction side and pressure side	19
4.5.2	Max. operating pressure suction side	19
4.6	Dimensions	19
<b>5</b>	<b>Transport and storage</b>	<b>20</b>

5.1	General	20
5.2	Transport	20
5.3	Storage	21
<b>6</b>	<b>Installation</b>	<b>23</b>
6.1	Safety instructions for installation	23
6.2	Noise reduction	24
6.3	Mechanical installation	24
6.3.1	Preparation	24
6.3.2	Pumps with free shaft end	25
6.3.3	Coupling Type "R."	26
6.3.4	Coupling Type BoWex©	31
6.4	Connection lines	35
6.4.1	General	35
6.4.2	Suction line design	35
6.4.3	Pressure line design	37
6.4.4	Mounting Connection lines	37
6.5	Change of the direction of rotation	37
<b>7</b>	<b>Operation start-up</b>	<b>38</b>
7.1	Safety instructions for start-up	38
7.2	Filling the quench chamber	39
7.3	Further operation start-up	40
<b>8</b>	<b>Removal</b>	<b>41</b>
8.1	Safety instructions for removal	41
8.2	Removal	42
<b>9</b>	<b>Maintenance</b>	<b>43</b>
9.1	Safety instructions for maintenance	43
9.2	Maintenance work	44
9.3	Maintenance instructions	45
<b>10</b>	<b>Repairs</b>	<b>47</b>
10.1	Safety instructions for repair	47
10.2	General	48
10.3	Detecting and eliminating failures	49

## 1 General

### 1.1 About the documentation

These operating instructions describe the installation, operation and maintenance of the following device:

#### **High pressure gear pump KP 2/. .../434, KP 3/. .../434, KP 5/. .../434**

The device is manufactured in different versions. Information about the version concerned in the individual case can be found on the device's type plate.

These operating instructions are a component of the device and must be kept accessible for the personnel near the device at all times.

If you have any questions about these operating instructions, please contact the manufacturer.

### 1.2 Manufacturer's address

KRACHT GmbH  
Gewerbestraße 20  
DE 58791 Werdohl  
phone: +49 2392 935-0  
fax: +49 2392 935-209  
email: [info@kracht.eu](mailto:info@kracht.eu)  
web: [www.kracht.eu](http://www.kracht.eu)

### 1.3 Applicable documents

1. KTR Kupplungstechnik GmbH, DE 48407 Rheine
  - KTR-N 40210: Coupling operating/assembly instruction Rotex
  - KTR-N 40110: Operating/assembly instructions BoWex© coupling

Excerpts from these documents are included in these operating instructions.

If required, the original documents can be requested from the respective manufacturer.

## 1.4 Symbolism



Identification of an immediate hazard, which would result in death or severe bodily injury if not avoided.



Identification of a potential medium risk hazard, which would lead to death or severe bodily injury if not avoided.



Identification of a low risk hazard, which could lead to minor or medium bodily injury if not avoided.



Flagging of notices to prevent property damage.



Identification of basic safety instructions. Non-compliance can lead to hazards for people and the device.



Flagging of special user tips and other especially useful or important information.

## 2 Safety

### 2.1 Intended use

1. The device has been designed for operation with fluid. Dry operation is not permitted.
2. The device may be operated in filled condition only.  
The medium must be compatible with the materials used in the device. The chemical competence is necessary for this. Be careful with ethylene oxide or other cathalytic or exothermic or self-decomposing materials. Please consult the manufacturer in cases of doubt.
3. The device may be operated only in usual industrial atmospheres. If there are any aggressive substances in the air, always ask the manufacturer.
4. Operation of the device is only permissible when complying with the operating instructions and applicable documents.  
Deviating operating conditions require the express approval of the manufacturer.
5. In case of any use of the device not according to specification, any warranty is voided.

### 2.2 Personnel qualification and training

The staff designated to assemble, operate and service the device must be properly qualified. This can be through training or specific instruction. Personnel must be familiar with the contents of this operating instructions.



Read the operating instructions thoroughly before use.

### 2.3 Basic safety instructions



1. Comply with existing regulations on accident prevention and safety at work along with any possible internal operator regulations.
2. Pay attention to the greatest possible cleanliness.
3. Wear suitable personal protection equipment.
4. Do not remove, make illegible or obliterate type plates or other references on the device.
5. Do not make any technical changes on the device.
6. Maintain and clean the device regularly.
7. Use spare parts approved by the manufacturer only.

**2.4 Basic hazards**

 **DANGER**

**Hazardous fluids!**

Danger of death when handling hazardous fluids.

1. Comply with the safety data sheets and regulations on handling hazardous fluids.
2. Collect and dispose of hazardous fluids so that no hazards arise for people or the environment.

 **DANGER**

**Rotating parts!**

Danger of death due to body parts, hair or clothing getting trapped or entangled.

1. Before all work, ensure that existing drives are voltage-free and pressure-free.
2. Securely prevent restarting during all work.

 **WARNING**

**Rotating parts!**

Danger of injury from flying parts.

1. Enclose rotating parts so as to avoid any danger from flying parts in the event of breakage or malfunction.

 **WARNING**

**Failure of load-carrying parts due to overload!**

Danger of injury from flying parts.

Danger of injury from spurting fluids.

1. Depressurise the device and all connection lines before doing any work.
2. Securely prevent the restoration of pressure while working on the device.



## WARNING

### **Failure of load-carrying parts due to overload!**

Danger of injury from flying parts.

Danger of injury from spurting fluids.

1. Use only connections and lines approved for the expected pressure range.
2. Securely prevent exceeding the permissible pressure, e.g. by using pressure relief valves or rupture discs.
3. Design pipework so that no tensions, e.g. caused by changes in length due to fluctuations in temperature, are transmitted to the device.



## WARNING

### **Failure of load-carrying parts due to overload!**

Danger of injury from flying parts.

Danger of injury from spurting fluids.

1. Do not operate the device against closed shut-off devices.
2. Do not operate the device in the false direction of rotation.



### 3 Device description

#### 3.1 Functional principle

KP series pumps are external gear pump types that work according to the positive displacement principle.

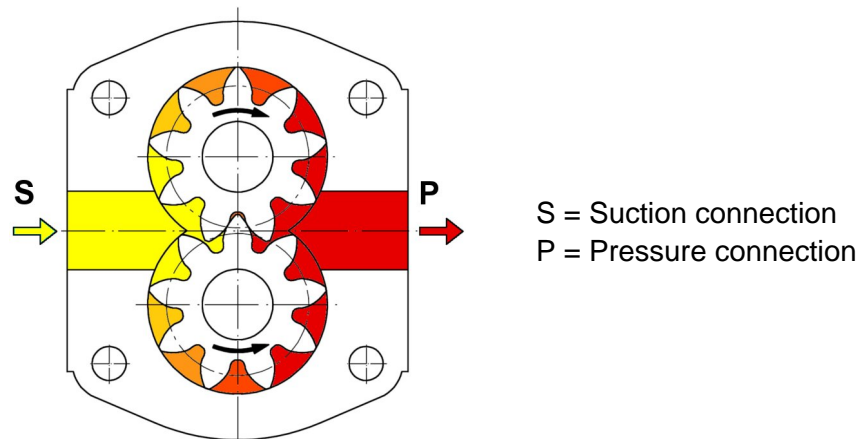

When rotated, two gearwheels meshing together produce a volume enlargement as a result of the opening of the tooth spaces on the suction side (S), so that medium can flow in and so that a corresponding volume is displaced simultaneously by immersion of the teeth into the filled tooth spaces on the pressure side (P). Fluid transport takes place through entrainment in the tooth gaps along the wall of the wheel chamber. The so-called geometric flow rate  $V_g$  is being displaced per wheel rotation. A value that is stated in technical documents as rated volume  $V_{gn}$  to specify the pump size.

The actually delivered amount of liquid does not correspond with the theoretical value, it is being reduced through losses due to the necessary tolerances. The losses are less the lower the operating pressure and the higher the viscosity of the medium.

Gear pumps are self-priming within wide limits. The displacement cycle describe initially takes place without exhibiting appreciable pressure build-up. Only after setting external loads, for example, through delivery heights, flow resistances, line elements, etc. will the required working pressure arise to overcome these resistances.

As usual with non-axial play compensated pumps, the lateral clearance between gear and front face has been set in such a way that the maximum allowable operating pressure is managed in an adequate and secure way.

Bearing and shaft seal of the device are lubricated by the media. The device's operating life will be reduced if the medium contains abrasive ingredients.

The shaft seal chamber is connected to the device's suction side. The pressure occurring at the shaft seal therefore corresponds to the pressure at the

suction connection of the device. The permissible pressure is determined by the type of sealing.

## 3.2 Basic construction

### 3.2.1 KP 2/. + KP 3/. ... /434

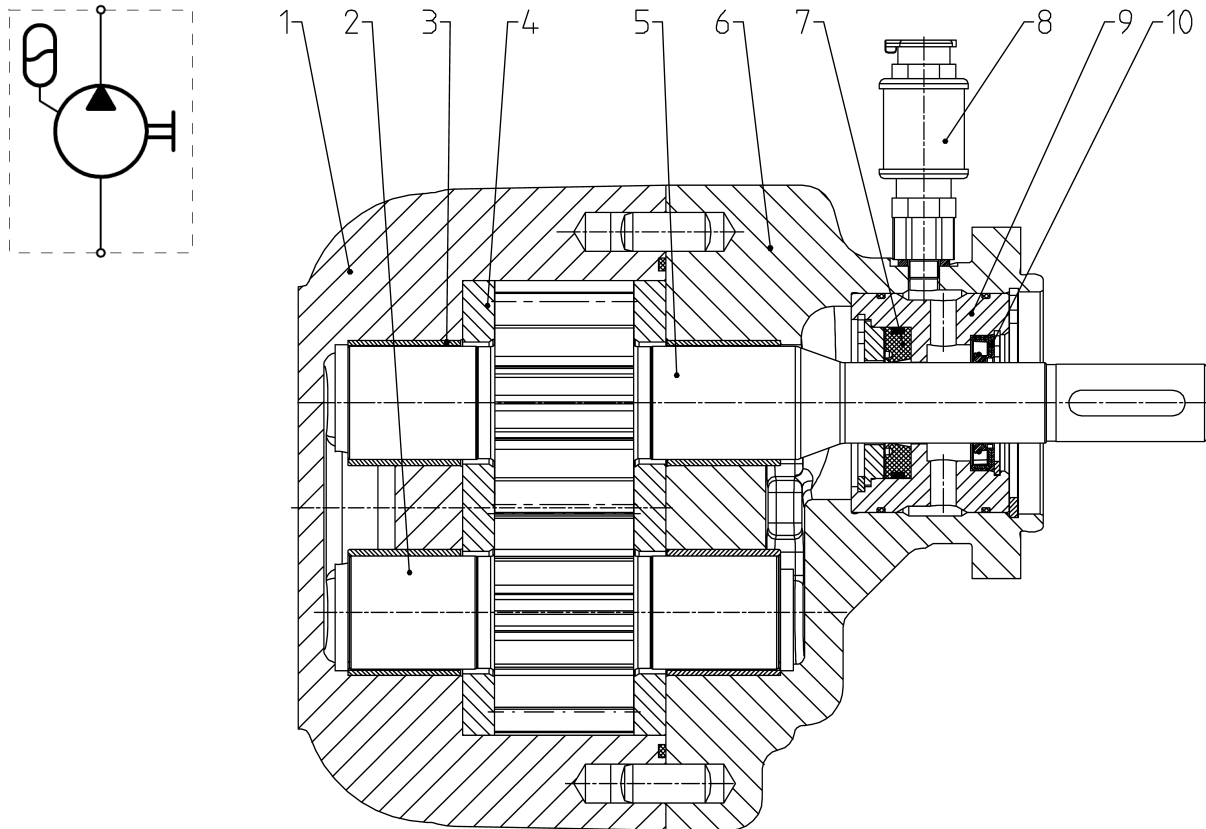

#### Explanation

- |                       |                                |
|-----------------------|--------------------------------|
| 1. Housing            | 6. Flange cover                |
| 2. Driven shaft       | 7. Shaft seal                  |
| 3. Plain bearing bush | 8. Container for quench-liquid |
| 4. Slide plate        | 9. Seal retainer               |
| 5. Driving shaft      | 10. Shaft seal                 |

## 3.2.2 KP 5/ ... /434

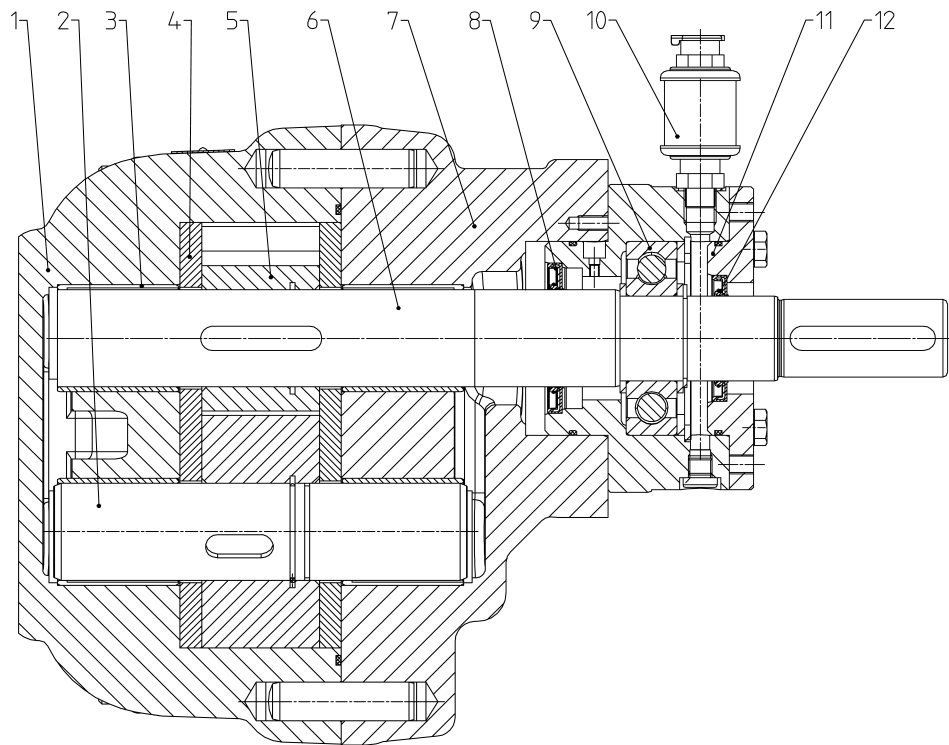
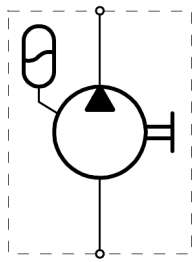

### Explanation

- |                       |                                 |
|-----------------------|---------------------------------|
| 1. Housing            | 7. Flange cover                 |
| 2. Bolt               | 8. Shaft seal                   |
| 3. Plain bearing bush | 9. Outbord bearing              |
| 4. Slide plate        | 10. Container for quench-liquid |
| 5. Gear               | 11. Centring disc               |
| 6. Shaft              | 12. Shaft seal                  |

### 3.3 Rotation and delivery direction

The following definition applies with respect to the rotation and delivery direction of external gear pumps for pump connections positioned below the drive shaft:

Looking at the pump shaft end, the pumping flow is from left to right when the shaft is moving clockwise.

Looking at the pump shaft end, the pumping flow is from right to left when the shaft is moving counter-clockwise.

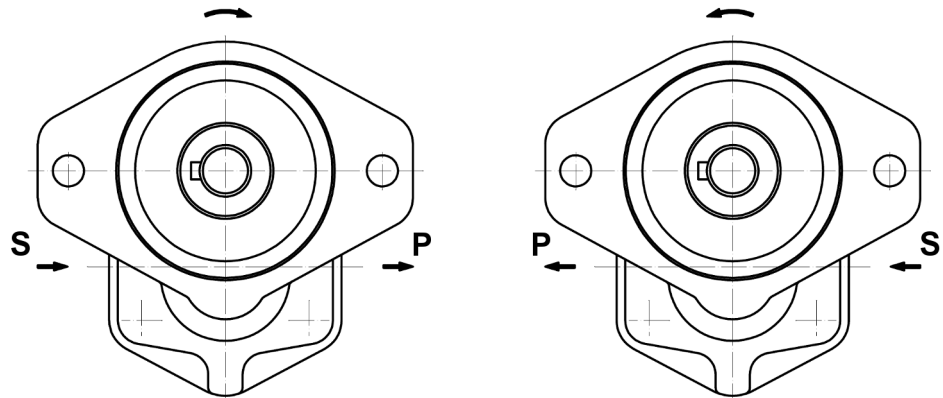

S = Suction connection

P = Pressure connection

The direction of rotation is indicated by the bent arrow.

The flow direction is indicated by the straight arrows.

### 3.4 Quench

Versions with quench are used when absolute leak tightness is required on the shaft seal, e.g. when pumping media

- which cures upon contact with air.
- which crystallises upon contact with air humidity.
- the leakage of which must not be released into the environment.
- are under vacuum and their seal shall be gastight.

Select the mounting position so that the connection for the quench faces up.

## 3.5 Type key

Ordering example KP 2/. - KP 5/. ... /434															
KP	2	/	20	X	1	0	G	Y	0	0	4	D	L	2	/434
1.	2.		3.	4.	5.	6.	7.	8.	9.	10.	11.	12.	13.	14.	15.

Explanation of type key KP 2/. - KP 5/. .../434								
1.	Product name							
2.	Size							
	2; 3; 5							
3.	Nominal size							
	<table border="1"> <tr> <td><math>V_{gn}</math></td> <td> <b>Size 2:</b> 28; 40  <b>Size 3:</b> 63; 100; 125  <b>Size 5:</b> 150; 200; 250                 </td> </tr> </table>	$V_{gn}$	<b>Size 2:</b> 28; 40 <b>Size 3:</b> 63; 100; 125 <b>Size 5:</b> 150; 200; 250					
$V_{gn}$	<b>Size 2:</b> 28; 40 <b>Size 3:</b> 63; 100; 125 <b>Size 5:</b> 150; 200; 250							
4.	Flange cover version							
	<table border="1"> <tr> <td rowspan="2">X</td> <td>KP 2/.</td> <td rowspan="2">Rectangular 4-hole flange LA = □ 80; ØZ = 80</td> </tr> <tr> <td>KP 3/.</td> </tr> <tr> <td>C</td> <td>KP 5/.</td> <td>SAE-C-2-hole flange LA = 181; ØZ = 127</td> </tr> </table>	X	KP 2/.	Rectangular 4-hole flange LA = □ 80; ØZ = 80	KP 3/.	C	KP 5/.	SAE-C-2-hole flange LA = 181; ØZ = 127
	X		KP 2/.		Rectangular 4-hole flange LA = □ 80; ØZ = 80			
		KP 3/.						
C	KP 5/.	SAE-C-2-hole flange LA = 181; ØZ = 127						
LA = Hole distance; ØZ = Centering diameter								
5.	Direction of rotation							
	<table border="1"> <tr> <td>1</td> <td>Clockwise</td> <td>2</td> <td>Counterclockwise</td> </tr> </table>	1	Clockwise	2	Counterclockwise			
1	Clockwise	2	Counterclockwise					
6.	Outboard flange							
	<table border="1"> <tr> <td>0</td> <td>Without</td> </tr> </table>	0	Without					
0	Without							
7.	Housing connection <sup>(1)</sup>							
	F	KP 2/28	Suction side Flange connection SAE 1 1/4" (M12)					
			Pressure side Flange connection SAE 1"					
	G	KP 2/40 KP 3/60	Suction side Flange connection SAE 1 1/2"					
			Pressure side Flange connection SAE 1 1/4" (M12)					
	J	KP 3/100 KP 3/125	Suction side Flange connection SAE 2"					
			Pressure side Flange connection SAE 1 1/4" (M12)					
	K	KP 5/150 KP 5/200 KP 5/250	Suction side Flange connection SAE 2 1/2"					
Pressure side Flange connection SAE 2"								

Explanation of type key KP 2/. - KP 5/. .../434			
8.	<b>Shaft end</b>		
	Y	KP 2/. KP 3/.	Cylindrical shaft end Ø 28
		Z	KP 5/.
9.	<b>2nd shaft end</b>		
	0	Without	
10.	<b>Adapter</b>		
	0	Without	
11.	<b>Design serial number</b>		
	4	KP 2/. (specified by manufacturer)	
	6	KP 3/. (specified by manufacturer)	
	0	KP 5/. (specified by manufacturer)	
12.	<b>Housing and bearing version</b>		
	D	Iron cast housing with multi-component plain bearings	
13.	<b>Gears version</b>		
	L	KP 2/.	
		KP 3/.	
	E	KP 5/.	
14.	<b>Sealing material</b>		
	2	FKM	
15.	<b>Code for special versions</b>		
	434	Double rotary shaft seal Container for quench-liquid	
<sup>(1)</sup> Flange connection: ISO 6162-1 (SAE J518)			

## 4 Technical data

### 4.1 General

General information KP 2/. - KP 5/. .../434		
<b>Construction</b>		External gear pump
<b>Fixing type</b>	KP 2/.	Rectangular 4-hole flange DIN ISO 7653
	KP 3/.	
	KP 5/.	SAE-C-2-hole flange
<b>End of drive shaft</b>		Cylindrical shaft end
<b>Housing connection</b>		See <a href="#">section 3.5 "Type key"</a>
<b>Mounting position</b>		Shaft end horizontal, fluid buffer connection top
<b>Viscosity</b>	$v_{\min}$	34 mm <sup>2</sup> /s
	$v_{\max}$	50000 mm <sup>2</sup> /s
<b>Ambient temperature</b>	$\vartheta_u$	-20 °C ≤ T <sub>a</sub> ≤ 60 °C
<b>Speed</b>	n	See <a href="#">section 4.2 "Overview nominal sizes"</a>
<b>Operating pressure</b>	$p_e$	See <a href="#">section 4.5 "Permissible pressure range"</a>
	$p_b$	
<b>Fluid temperature</b>	$\vartheta_{m \max}$	120 °C
<b>External loads on shaft end</b>		See <a href="#">section 4.2 "Overview nominal sizes"</a>
<b>Material</b>		See <a href="#">section 4.4 "Material data"</a>
<b>Filtering</b>		Compliant with ISO 4406: 1999 Class 21/19/16
<b>Permissible media</b>		Lubricating fluids without abrasive components. Polyols Silicates (sodium silicate) Isocyanates Petrols, solvents, etc. are not permissible.

### 4.2 Overview nominal sizes

Nominal size $V_{gn}$	Geom. displacement $V_g$ [cm <sup>3</sup> /rev.]	Perm. radial force $F_{\text{radial}}$ [N]	Permissible axial force $F_{\text{axial}}$ [N]	Mass inertia x10 <sup>-5</sup> J [kg m <sup>2</sup> ]	Weight [kg]
2/28	27,7	-	-	27,9	15
2/40	39,4			37,6	16
3/63	62,5			100,9	25
3/100	99,5			145,5	29
3/125	123,8			174,8	32



Nominal size $V_{gn}$	Geom. displacement $V_g$ [cm <sup>3</sup> /rev.]	Perm. radial force $F_{radial}$ [N]	Permissible axial force $F_{axial}$ [N]	Mass inertia $\times 10^{-5}$ J [kg m <sup>2</sup> ]	Weight [kg]
5/150	147,5	1500	400	308,7	49
5/200	196,1			386,8	53
5/250	244,7			464,8	57

### 4.3 Viscosity - Rotation speed assignment

#### 4.3.1 Max. speed depending on the viscosity

Kinematic viscosity $\nu$ [mm <sup>2</sup> /s]				
< 1000	1500	2300	4000	50000
1450	1100	875	700	175
Speed $n_{max}$ [rpm]				

#### 4.3.2 Min. speed depending on the viscosity and pressure

$p_b = 50$ bar				
Kinematic viscosity $\nu$ [mm <sup>2</sup> /s]				
34	100	350	1000	7000
$\geq 500$	280	100	30	30
Speed $n_{min}$ [rpm]				

$p_b = 100$ bar					
Kinematic viscosity $\nu$ [mm <sup>2</sup> /s]					
34	100	300	600	1000	7000
$\geq 1000$	500	200	80	30	30
Speed $n_{min}$ [rpm]					

## 4.4 Material data

<b>KP 2/. .../434 + KP 3/. .../434</b>				
<b>Shaft seal</b>	<b>O-rings</b>	<b>Housing/Flange cover</b>	<b>Gears</b>	<b>Bearing</b>
Turcon© FKM	FKM	EN-GJL-300 (GG-30)	Case-hardened steel (1.7139)	Multi layer friction bearings contains lead (Standard) DU, P10 (Steel, CuSn, PTFE, Pb)

<b>KP 5/. .../434</b>				
<b>Shaft seal</b>	<b>O-rings</b>	<b>Housing/Flange cover</b>	<b>Gears</b>	<b>Bearing</b>
FKM	FKM	EN-GJL-300 (GG-30)	Case-hardened steel (1.7139)	Multi layer friction bearings con- tains lead (Standard) DU, P10 (Steel, CuSn, PTFE, Pb)

## 4.5 Permissible pressure range

### 4.5.1 Operating pressure of suction side and pressure side

Nominal size $V_{gn}$	Operating pressure		
	Suction side		Pressure side
	$p_{e\ min}$ [bar abs.]	$p_{e\ max}$ [bar]	$p_b$ [bar] (perm. continuous pressure)
2/28	0,6	See <a href="#">section 4.5.2</a> "Max. operating pressure suction side"	150
2/40			
3/63			
3/100			110
3/125			
5/150			100
5/200			
5/250			

### 4.5.2 Max. operating pressure suction side

Speed $n_{max}$ [rpm]	$p_{e\ max}$ [bar]		
	KP 2/.	KP 3/.	KP 5/.
400	20	20	9
500	16	16	
750	11	11	5,5
1000	8	8	4,5
1500	5	5	3

## 4.6 Dimensions

Dimensions of the device can be found in the relevant technical data sheets.

## 5 Transport and storage

### 5.1 General

- After receipt, check the device for transport damages.
- If transport damage is noticed, report this immediately to the manufacturer and the carrier. The device must then be replaced or repaired.
- Dispose of packing material and used parts in accordance with the local stipulations.

### 5.2 Transport



#### WARNING

##### Falling or overturning loads!

Danger of injury while transporting large and heavy loads.

1. Use only suitable means of conveyance and lifting tackle with sufficient load-bearing capacity.
2. Attach lifting tackle only to suitable load points.
3. Attach the lifting tackle in such a manner that it cannot slip.
4. Pay attention to the load balance point.
5. Always avoid jerks, impacts and strong vibrations during transportation.
6. Never walk under suspended loads, never work under suspended loads.



To transport the device, eyebolts can be screwed into the flange connections.

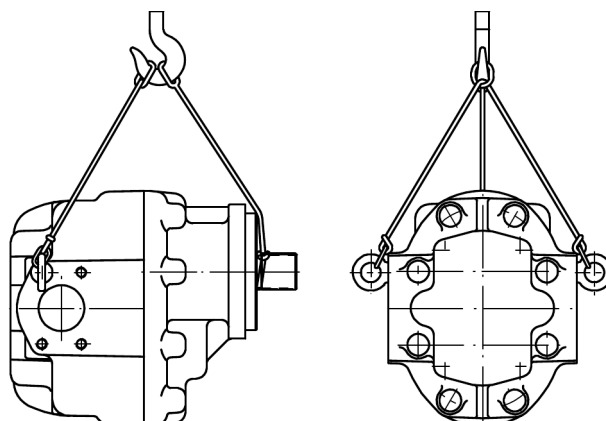

### 5.3 Storage

The device's function is tested in the plant with mineral hydraulic oil. Then all connections are closed. The remaining residual oil preserves the interior parts for up to 6 months.

Metallic exposed exterior parts are protected against corrosion by suitable conservation measures, also up to 6 months.

In case of storage, a dry, dust-free and low-vibration environment is to be ensured. The device is to be protected against influences from weather, moisture and strong fluctuations of temperature. The recommended storage conditions are to be adhered to.

Below the permissible ambient temperature  $\vartheta_u$  elastomer seals lose their elasticity and mechanical loading capacity, since the glass transition temperature is fallen below. This procedure is reversible. A force action on the device is to be avoided in case of storage below the permissible ambient temperature  $\vartheta_u$ .

Devices with EPDM seals are not mineral-oil resistant and are not tested for their function. There is no preservation of the interior parts. If the device is not taken into operation immediately, all corrosion-prone surfaces are to be protected by suitable conservation measures. The same applies for devices which are not tested for other reasons.

When storing for a long period of time (> 6 months), treat all surfaces at risk of corrosion again with suitable preserving agents.

If high air humidity or aggressive atmospheres are expected, take additional corrosion-preventing measures.



Storage in corrosion protection bags (VCI) maximum of 6 months.



#### NOTICE

##### **Corrosion/chemical impact**

Improper storage can render the device useless.

1. Protect endangered surfaces by means of suitable conservation measures.
2. Comply with recommended storage conditions.

**Recommended storage conditions**

1. Storage temperature: 5 °C - 25 °C
2. Relative air humidity: < 70 %
3. Protect elastomer parts from light, especially direct sunlight.
4. Protect elastomer parts from oxygen and ozone.
5. Comply with maximum storage times of elastomeric parts:
  - 5 Years: AU
  - 7 Years: NBR, HNBR, CR
  - 10 Years: EPM, EPDM, FEP/PTFE, FEPM, FKM, FFKM, VMQ, FVMQ

## 6 Installation

### 6.1 Safety instructions for installation

#### **DANGER**

##### **Hazardous fluids!**

Danger of death when handling hazardous fluids.

1. Comply with the safety data sheets and regulations on handling hazardous fluids.
2. Collect and dispose of hazardous fluids so that no hazards arise for people or the environment.

#### **DANGER**

##### **Rotating parts!**

Danger of death due to body parts, hair or clothing getting trapped or entangled.

1. Before all work, ensure that existing drives are voltage-free and pressure-free.
2. Securely prevent restarting during all work.

#### **DANGER**

##### **Rotating parts!**

Danger of death due to body parts, hair or clothing getting trapped or entangled.

1. Take measures against accidental touching of rotating parts.

#### **WARNING**

##### **Rotating parts!**

Danger of injury from flying parts.

1. Enclose rotating parts so as to avoid any danger from flying parts in the event of breakage or malfunction.

#### **WARNING**

##### **Unshielded gearwheels!**

Gearwheels can trap and crush fingers and hands.

1. Do not engage gearwheels.



## WARNING

### Failure of load-carrying parts due to overload!

Danger of injury from flying parts.

Danger of injury from spurting fluids.

1. Depressurise the device and all connection lines before doing any work.
2. Securely prevent the restoration of pressure while working on the device.

## 6.2 Noise reduction



### Measures for noise reduction

1. Use suction and pressure hoses.
2. Use bell housings with high damping properties (plastic or cast iron).
3. Use of damping rings and damping rods for separation of structure-borne noise.

## 6.3 Mechanical installation

### 6.3.1 Preparation

- Check the device for transport damage and dirt.
- Check the device for freedom of movement.
- Remove existing preservatives.
  - Use only those cleaning agents that are compatible with the materials used in the device.
  - Do not use cleaning wool.
- Compare the environmental and ambient conditions at the place of installation to the permissible conditions.
  - Ensure a sufficiently stable and level foundation.
  - Expose the device only to small vibrations, see IEC 60034-14.
  - Secure sufficient access for maintenance and repair.



### 6.3.2 Pumps with free shaft end

The prerequisite for trouble-free operation is suitable load transmission between the pump and the drive.

Coupling types in use:

1. KP 2/. + KP 3/.: Torsionally flexible claw coupling type "R."
2. KP 5/.: Crowned tooth coupling type **BoWex**©
  - Pre-mount coupling parts as per manufacturer's specifications.



Torsionally flexible claw coupling type "R.": See [section 6.3.3 "Coupling Type "R.""](#)



Crowned tooth coupling type **BoWex**©: See [section 6.3.4 "Coupling Type BoWex©"](#)

- Position the pumps and the drive with respect to each other.
  - Comply with the permissible mounting position.
  - Comply with the permissible direction of rotation.



Rotation and delivery direction: See [chapter 3 "Device description"](#)

- Tighten all fastening screws with the specified torque.
  - Keep to the permissible displacement values of the coupling.
  - Rule out any distortion of the device.
  - Pay attention to sufficient screw-in depth of the fastening screws.

#### Tightening torques [Nm]

Thread size <sup>(1)</sup>	M6	M8	M10	M12	M16	M20	M24
<b>Counter-thread Aluminium</b>	4,6	11	22	39	95	184	315
<b>Counter-thread Cast iron/Steel</b>	10	25	49	85	210	425	730

<sup>(1)</sup> Screws/Nuts with min. strength class 8.8/8

- For devices without shaft seals, ensure that the leak oil from the shaft sealing chamber is specifically drained off and cannot get into the environment.
- Make sure no foreign bodies can get into the device.
- Take measures against accidental touching of rotating parts.
- Take measures against accidental touching of hot surfaces (> 60 °C).

## Liquid seal

- On devices with quench, mount a tank for the liquid seal.
  - Mount the tank above the device.
  - The connection on the device must point upward.
  - Checking the fluid level must be possible at any time.



A second port on the unit enables purging of the quench chamber and draining of the liquid seal.

### 6.3.3 Coupling Type "R."

Claw couplings Type "R." are torsionally flexible and transmit the torque positive. They are fail-safe. The vibrations and impacts that occur during operation are effectively dampened and reduced.

#### Claw coupling Type "R."

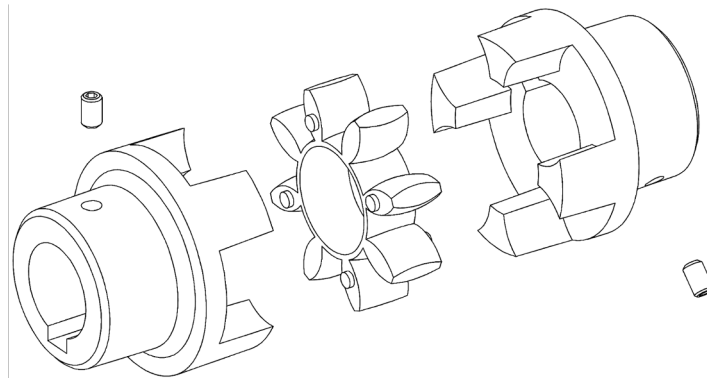

#### NOTICE

##### **Coupling breakage or increased wear**

An overload can lead to premature failure of the coupling.

1. Ensure safe dimensioning when designing the coupling. Take vibrations, torque peaks and temperatures into account.

**Assembly data**

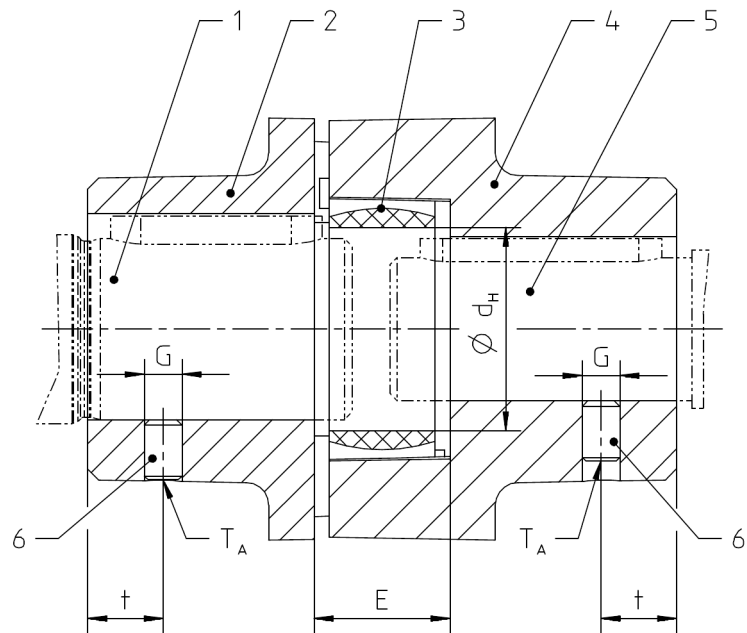

**Explanation**

- |                               |   |
|-------------------------------|---|
| 1. Shaft projects into spider | 4. Coupling halve                               |
| 2. Coupling halve             | 5. Shaft with parallel key projects into spider |
| 3. Spider                     | 6. Setscrew                                     |

When installing the coupling, maintain the "E" gap dimension so that the spider remains free during operation. If the shaft diameters are less than (also with parallel key) the dimension  $d_H$  of the spider, the shaft ends can protrude out into the spider.

Coupling size <sup>(1)</sup>	14	19	24	28	38	42	48	55	65	75
	-	19/24	24/28	28/38	38/45	42/55	48/60	55/70	65/75	75/90
Coupling clearance E [mm]	13	16	18	20	24	26	28	30	35	40
$d_H$ [mm]	10	18	27	30	38	46	51	60	68	80
G	M4	M5	M5	M8	M8	M8	M8	M10	M10	M10
t [mm]	5	10	10	15	15	20	20	20	20	25
Tightening torque $T_A$ [Nm]	1,5	2	2	10	10	10	10	17	17	17

<sup>(1)</sup> Example: R.19-Z25/14-Z25/19 or R.19/24-Z25/14-Z25/24.



For assembly, the coupling halves can be heated to approx. 80 °C and pushed onto the shaft ends while warm.

**Hot surfaces!**

Burn injury to skin if touched.

1. Wear protective gloves at temperatures  $\geq 48^{\circ}\text{C}$ .
- Mount the coupling halves on the shaft ends but avoid impacts on the components.
  - Position the coupling halves on the shaft ends so that in later operation the "E" gap dimension is maintained.
  - Secure the coupling halves by tightening the setscrews.
  - Insert the spider in a coupling half.

**Displacement values**

**Axial displacement**  
 $\Delta K_a$

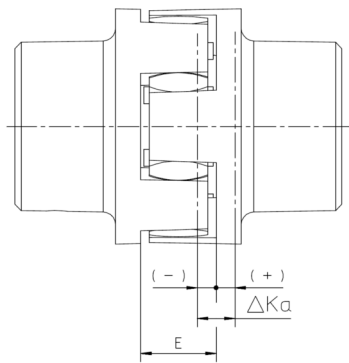

**Radial displacement**  
 $\Delta K_r$

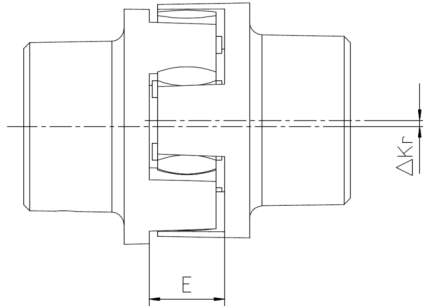

**Angular displacement**  
 $\Delta K_w / \Delta K_L$

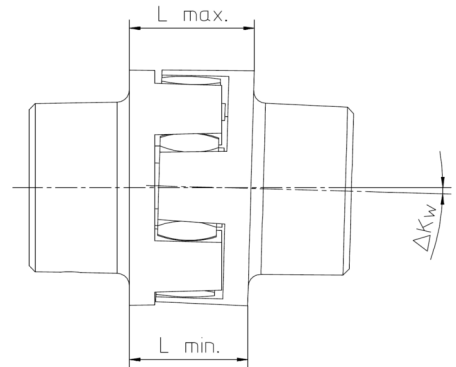

$$\Delta K_L \triangleq L_{\max} - L_{\min}$$

Coupling size		14	19	24	28	38	42	48	55	65	75
		-	19/24	24/28	28/38	38/45	42/55	48/60	55/70	65/75	75/90
Coupling clearance E [mm]		13	16	18	20	24	26	28	30	35	40
$\Delta K_a$ [mm]		+1,0 -0,5	+1,2 -0,5	+1,4 -0,5	+1,5 -0,7	+1,8 -0,7	+2,0 -1,0	+2,1 -1,0	+2,2 -1,0	+2,6 -1,0	+3,0 -1,5
$\Delta K_r$ [mm]	1500 rpm	0,11	0,13	0,15	0,18	0,21	0,23	0,25	0,27	0,30	0,34
	3000 rpm	0,08	0,09	0,1	0,13	0,15	0,16	0,18	0,19	0,21	0,24
$\Delta K_w$ [De- gree]	1500 rpm	1,1	1,1	0,8	0,8	0,9	0,9	1,0	1,0	1,1	1,1
	3000 rpm	1,0	1,0	0,7	0,7	0,8	0,8	0,9	0,9	1,0	1,0
$\Delta K_L$ [mm]	1500 rpm	0,57	0,77	0,77	0,90	1,25	1,40	1,80	2,00	2,50	3,00
	3000 rpm	0,52	0,7	0,67	0,80	1,00	1,30	1,60	1,80	2,20	2,70

## Displacement combinations

Examples for displacement combinations shown in the photo opposite:

*Example 1:*

$$\Delta K_r = 30 \%$$

$$\Delta K_w = 70 \%$$

*Example 2:*

$$\Delta K_r = 60 \%$$

$$\Delta K_w = 40 \%$$

$$\Delta K_r + \Delta K_w \leq 100 \%$$

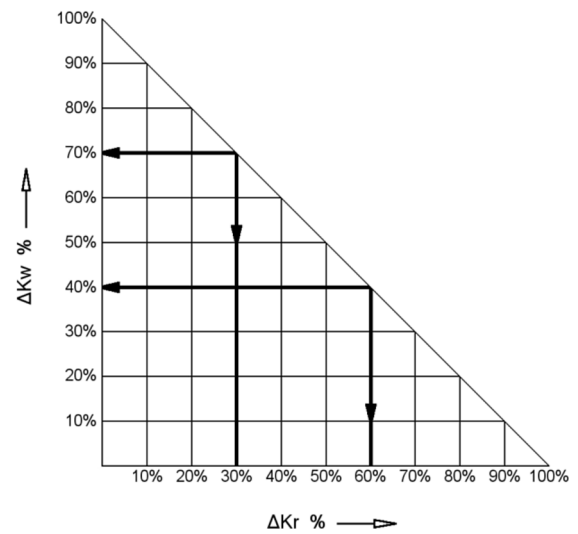

### 6.3.4 Coupling Type BoWex®

Type BoWex® crowned tooth couplings are flexible and transmit the torque positive. You can compensate for shaft misalignment caused, e.g., by thermal expansion or installation inaccuracies.

#### Crowned tooth coupling type BoWex®

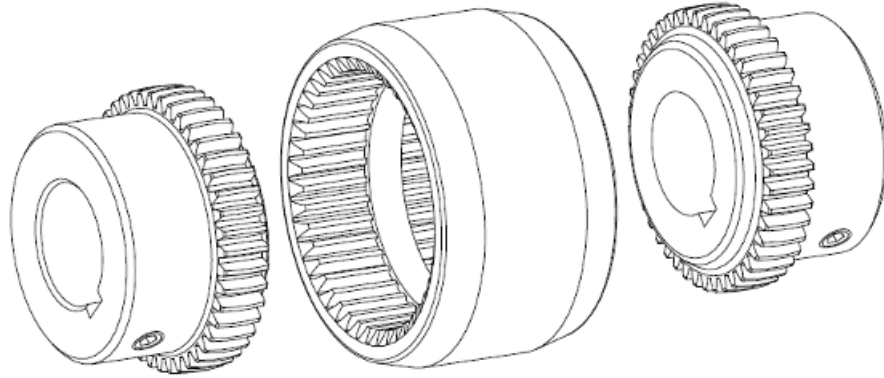

#### NOTICE

##### **Coupling breakage or increased wear**

An overload can lead to premature failure of the coupling.

1. Ensure safe dimensioning when designing the coupling. Take vibrations, torque peaks and temperatures into account.

### Assembly data

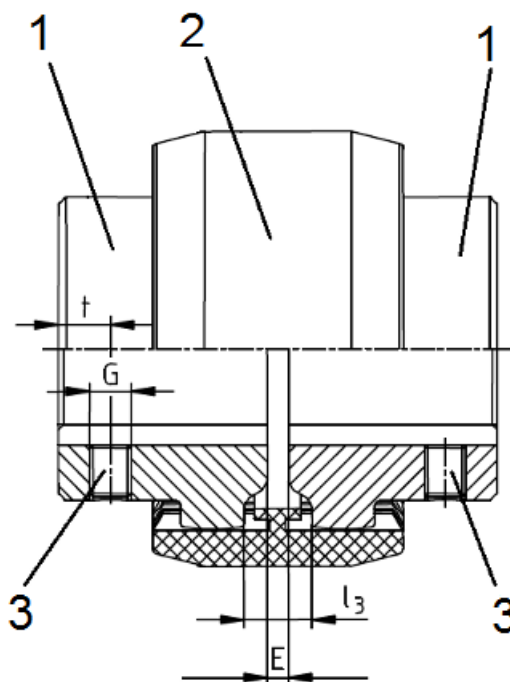

### Explanation

- 1. Coupling halve
- 2. Coupling sleeve
- 3. Setscrew

When installing the coupling, maintain the "E" gap dimension so that the coupling sleeve remains free during operation.

Coupling size	M-19	M-24	M-28	M-32	M-38	M-42	M-48	M-65
Coupling clearance E [mm]	4	4	4	4	4	4	4	4
Shaft [mm]	Ø 20	Ø 24	Ø 28	Ø 32	Ø 38	Ø 42	Ø 48	Ø 65
G	M5	M5	M8	M8	M8	M8	M8	M10
t [mm]	6	6	10	10	10	10	10	10
Tightening torque $T_A$ [Nm]	2	2	10	10	10	10	10	17





For assembly, the coupling halves can be heated to approx. 80 °C and pushed onto the shaft ends while warm.



**Hot surfaces!**

Burn injury to skin if touched.

1. Wear protective gloves at temperatures  $\geq 48^{\circ}\text{C}$ .
- Mount the coupling halves on the shaft ends but avoid impacts on the components.
  - Position the coupling halves on the shaft ends so that in later operation the "E" gap dimension is maintained.
  - Secure the coupling halves by tightening the setscrews.
  - Push the coupling sleeve onto the coupling halves.

**Axial displacement**  
 $\Delta K_a$

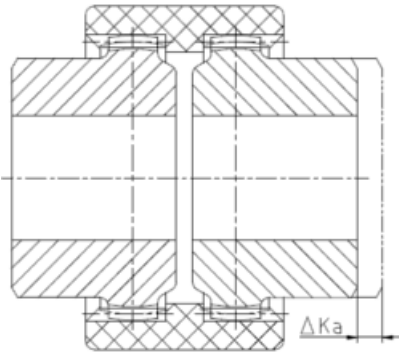

**Radial displacement**  
 $\Delta K_r$

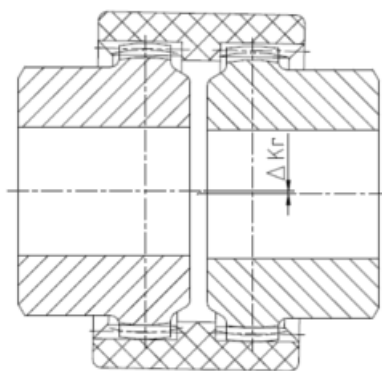

**Angular displacement**  
 $\Delta K_w$

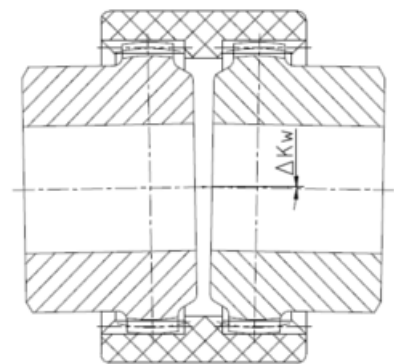

Displacement values									
Coupling size		19	24	28	32	38	42	48	65
$\Delta K_a$ [mm]		+1,0	+1,0	+1,0	+1,0	+1,0	+1,0	+1,0	+1,0
		-1,0	-1,0	-1,0	-1,0	-1,0	-1,0	-1,0	-1,0
$\Delta K_r$ [mm]	1500 rpm	0,30	0,35	0,35	0,35	0,40	0,40	0,40	0,45
	3000 rpm	0,20	0,23	0,23	0,23	0,25	0,25	0,25	0,28
$\Delta K_w$ [Degree]	1500 rpm	1,00	0,90	0,90	0,90	0,90	0,90	0,90	0,70
	3000 rpm	0,70	0,60	0,60	0,60	0,60	0,60	0,60	0,50

### Displacement combinations

Examples for displacement combinations shown in the photo opposite:

*Example 1:*

$$\Delta K_r = 30 \%$$

$$\Delta K_w = 70 \%$$

*Example 2:*

$$\Delta K_r = 60 \%$$

$$\Delta K_w = 40 \%$$

$$\Delta K_r + \Delta K_w \leq 100 \%$$

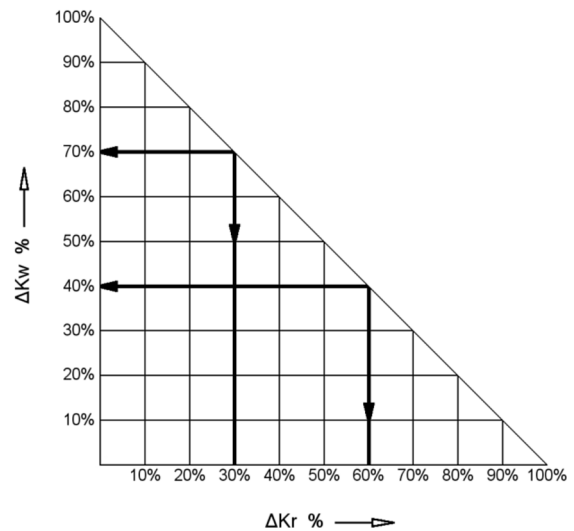

## 6.4 Connection lines

### 6.4.1 General



#### WARNING

##### Failure of load-carrying parts due to overload!

Danger of injury from flying parts.

Danger of injury from spurting fluids.

1. Use only connections and lines approved for the expected pressure range.
2. Securely prevent exceeding the permissible pressure, e.g. by using pressure relief valves or rupture discs.
3. Design pipework so that no tensions, e.g. caused by changes in length due to fluctuations in temperature, are transmitted to the device.



##### Additional connections

1. Provide measurement connections for pressure and temperature as close as possible to device.
2. If necessary, provide a facility to fill or empty the device and the line system.
3. If necessary, provide a facility to vent the device and the line system.

### 6.4.2 Suction line design

A less than optimally planned suction line can lead to increased noise emission, cavitation as well as reduction of the delivery rate (caused by not complete filling of the pump).

When designing the line, take the following points into consideration:

- The suction line must be piped as short as possible and in a straight line.
- Stipulate the nominal width of the suction line so that the permissible operating pressure  $p_{e\ min}$  is not exceeded on the suction side.
- Avoid large suction heights.
- Avoid additional pressure loss through line resistances such as fittings, screwed connections, formed parts or suction filters/suction baskets. Ensure that all technically required suction filters/suction baskets are appropriately dimensioned.
- Make sure there is sufficient clearance of the suction port to the bottom and walls of the media container.
- Make sure that the suction opening lies underneath the lowest fluid level in all operating situations.
- When hose lines are used, ensure sufficient stability of the hoses so that they cannot become constricted through the sucking action.

- Comply with the recommended flow velocity in the suction line (max. 1.5 m/s).

### Suction line at vacuum operation

If suction from a tank under vacuum is desired, the pump must be arranged approx. 1 m below the tank. The suction line must run in a straight line and without any resistances.

The tank may be subjected to vacuum only then when the pipework and the pump have been filled with liquid.

For this application, only pumps suitable for vacuum operation may be used.

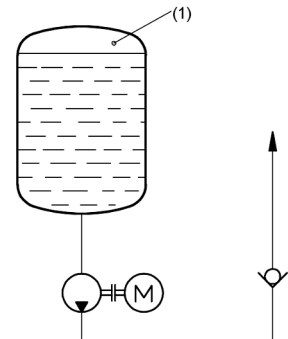

(1) Vacuum



### NOTICE

#### Cavitation damage

Undercutting the permissible suction port pressure results in cavitation.

1. Design the suction line so that the pressure arising in operation on the suction side is always higher than the vapour pressure of the pumped medium. At the same time, comply with the installation altitude of the device above mean sea level.
2. For aqueous fluids, mount the device underneath the fluid level, set the operating temperature to 50 °C and limit the speed to 1500 rpm.

#### Prevention of suction problems

If there is a possibility that the suction line can run dry if the pump stops, piping the suction line as siphon is an option to avoid suction problems. This way, the pump will remain permanently filled after initial commissioning.

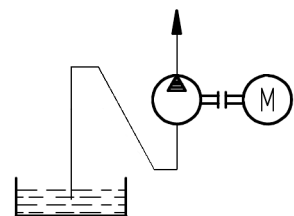

It is appropriate to employ a foot valve or a non-return valve in case of longer suction lines that can run dry while the pump is at rest. These must have been designed for use in suction lines and should offer as low a flow resistance as possible.

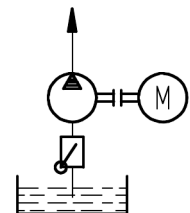

During operation of a pump that has to pump media via a non-return valve in a pressurized circuit (e.g. reserve pump in a lubricant circuit), suction problems can occur if the suction line is filled with air.

In this case the pressure pipe must be bled directly upstream of the non-return valve.

If no vent nozzle is used, the volume of the pressure pipe between the pump and the non-return valve must be at least 75 % of the suction line volume.

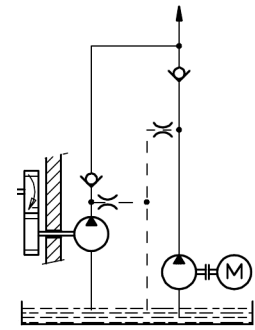

### 6.4.3 Pressure line design

When designing the line, take the following points into consideration:

- Select the nominal width of the pressure line so that the maximum permissible pressures are not exceeded.
- If necessary, provide a vent nozzle to prevent suction problems.

### 6.4.4 Mounting Connection lines



Position of the device connections: See [chapter 3 "Device description"](#)

- Clean all lines.
  - Do not use cleaning wool.
  - Pickle and flush welded pipes.
- Remove the protective plugs.
- Mount the lines.
  - Comply with the manufacturer's information.
  - Do not use sealants such as hemp or filler.

## 6.5 Change of the direction of rotation

A change in the direction of rotation is not possible.

## 7 Operation start-up

### 7.1 Safety instructions for start-up

#### **DANGER**

##### **Hazardous fluids!**

Danger of death when handling hazardous fluids.

1. Comply with the safety data sheets and regulations on handling hazardous fluids.
2. Collect and dispose of hazardous fluids so that no hazards arise for people or the environment.

#### **WARNING**

##### **Failure of load-carrying parts due to overload!**

Danger of injury from flying parts.

Danger of injury from spurting fluids.

1. Do not operate the device against closed shut-off devices.
2. Do not operate the device in the false direction of rotation.

#### **CAUTION**

##### **Hot surfaces!**

Burn injury to skin if touched.

1. Wear protective gloves at temperatures  $\geq 48^{\circ}\text{C}$ .

## 7.2 Filling the quench chamber

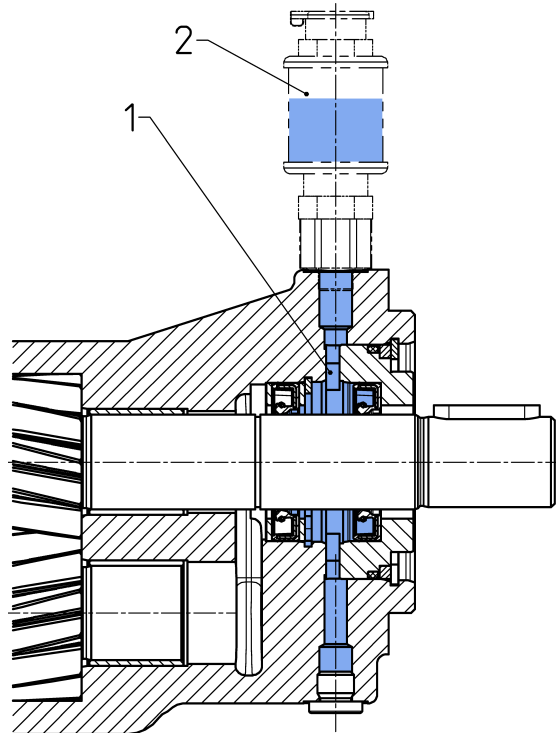

1. quench chamber
2. Container for quench-liquid (Accessories)

- For versions with quench, fill the quench chamber with a suitable liquid seal.
  - The filling is implemented through the tank provided for that.
  - Fill fluid until the quench chamber is completely full and the tank is half full.
- Do not apply pressure or vacuum to the quench chamber.



### NOTICE

#### Seal failure due to dry run

A lack of liquid seal can lead to a failure of the seal.

1. Do not put pumps without liquid seal into operation.



A second port on the unit enables purging of the quench chamber and draining of the liquid seal.

## 7.3 Further operation start-up

- Open existing shut-off elements upstream and downstream of the device.
- Adjust pressure relief valves in the system installed for lowest opening pressure.
- Allow the device start without or with a low pressure load (jog mode).
  - Flow should have developed after 30 s at the latest.
- Run the device for a few minutes depressurised or with low pressure.
- Vent the system at the highest possible point.
- Gradually increase the pressure load up to the desired operating pressure.
- Operate the system for so long until the final operating state is achieved.
- Check the operating data such as:
  - Discharge flow
  - Operating pressure (as close as possible to device)
  - Fluid temperature (as close as possible to device)
  - Device temperature (in particular in the area of the bearing points)
  - ...
- Document the operating data of the initial start-up for later comparison.
- Check the level of the operating medium in the system.
- Check the filling level of the liquid seal (if existing).
- Check the device for leaks.
- Check all threaded connections for leaks and retighten if necessary.



In order to ensure a constant and reliable function of the device, an initial maintenance of the device is recommended after several hours warm-up time (max. 24 h). Faults can thus be identified at an early stage.



## 8 Removal

### 8.1 Safety instructions for removal

#### DANGER

##### **Hazardous fluids!**

Danger of death when handling hazardous fluids.

1. Comply with the safety data sheets and regulations on handling hazardous fluids.
2. Collect and dispose of hazardous fluids so that no hazards arise for people or the environment.

#### DANGER

##### **Rotating parts!**

Danger of death due to body parts, hair or clothing getting trapped or entangled.

1. Before all work, ensure that existing drives are voltage-free and pressure-free.
2. Securely prevent restarting during all work.

#### WARNING

##### **Unshielded gearwheels!**

Gearwheels can trap and crush fingers and hands.

1. Do not engage gearwheels.

#### WARNING

##### **Failure of load-carrying parts due to overload!**

Danger of injury from flying parts.

Danger of injury from spurting fluids.

1. Depressurise the device and all connection lines before doing any work.
2. Securely prevent the restoration of pressure while working on the device.

#### CAUTION

##### **Hot surfaces!**

Burn injury to skin if touched.

1. At temperatures  $\geq 48^{\circ}\text{C}$  the device must be allowed to cool down first.

**NOTICE****Blocking of the device through hardening medium**

Hardening medium can mechanically jam the device and make it unusable.

1. Clean device immediately after operating with a hardening medium.

## 8.2 Removal

- Depressurise and de-energize the system.
- Close existing shut-off elements upstream and downstream of the device.
- Open existing drain elements and loosen connection lines. Collect and dispose of discharging medium so that no hazard arises for persons or environment.
- Dismantle the device.
- Clean the device.
- Close the device connections and lines to prevent dirt penetration.

## 9 Maintenance

### 9.1 Safety instructions for maintenance

 **DANGER****Hazardous fluids!**

Danger of death when handling hazardous fluids.

1. Comply with the safety data sheets and regulations on handling hazardous fluids.
2. Collect and dispose of hazardous fluids so that no hazards arise for people or the environment.

 **DANGER****Rotating parts!**

Danger of death due to body parts, hair or clothing getting trapped or entangled.

1. Before all work, ensure that existing drives are voltage-free and pressure-free.
2. Securely prevent restarting during all work.

 **WARNING****Failure of load-carrying parts due to overload!**

Danger of injury from flying parts.

Danger of injury from spurting fluids.

1. Depressurise the device and all connection lines before doing any work.
2. Securely prevent the restoration of pressure while working on the device.

 **CAUTION****Hot surfaces!**

Burn injury to skin if touched.

1. At temperatures  $\geq 48^{\circ}\text{C}$  the device must be allowed to cool down first.

## 9.2 Maintenance work



### Checking and documentation of the operating data

Regular checking and documentation of all operating data such as pressure, temperature, current consumption, degree of filter soiling, etc. contributes to early problem detection.

- Perform maintenance according to specification.
- Replace defective and worn components.
- If required, request spare parts lists and assembly drawings from the manufacturer.
- Document the type and scope of the maintenance work along with the operating data.
- Compare the operating data with the values of the first commissioning. Determine the cause in case of major non-compliances (> 10 %).
- Dispose of packing material and used parts in accordance with the local stipulations.



### Barriers and instructions

All barriers and warning signs removed during this must be attached to their original position on completing maintenance and/or repairs.

### 9.3 Maintenance instructions

The following information provides recommendations on maintenance work and maintenance intervals for the device being used.

Depending on the actually occurring loads in operation, the type, scope and interval of the maintenance work can deviate from the recommendations. The equipment builder/operator shall write an obligatory maintenance plan.



Within the framework of preventive maintenance, it is appropriate to replace wear parts before reaching the wear limit.

With corresponding expertise and sufficient equipment, the replacement can be carried out by the equipment builder/operator. Please consult the manufacturer about this.



**Warranty**  
In case of improper implementation, any warranty is voided.

Maintenance recommendations Gear pump			
Interval	Maintenance work	Employees	Duration approx. [h]
<b>Firstly: after max. 24 h</b>	Inspection: Discharge flow	1	1
	Inspection: Operating pressure		
	Inspection: Fluid temperature		
	Inspection: Device temperature		
	Inspection: Add-on valve function (if existing)		
	Inspection: Check potential equalisation for firm seating and functionality (if existing)		
	Inspection: Condition of operating fluid		
<b>Daily</b>	Audiometric monitoring: Unusual noise	1	0,1
	Cleaning: Remove dust deposits and dirt with a moist cloth		
	Visual inspection: Leakages		
	Visual inspection: Filling level of liquid seal (if existing)		

<b>Maintenance recommendations Gear pump</b>			
<b>Interval</b>	<b>Maintenance work</b>	<b>Employees</b>	<b>Duration approx. [h]</b>
<b>3000 Operating hours</b>	Inspection: Discharge flow	1	1
	Inspection: Operating pressure		
	Inspection: Fluid temperature		
	Inspection: Device temperature		
	Inspection: Add-on valve function (if existing)		
	Inspection: Check potential equalisation for firm seating and functionality (if existing)		
	Inspection: Condition of operating fluid		
<b>6000 Operating hours</b>	Visual inspection: Condition of gears	1	2
	Visual inspection: Condition of housing parts		
	Visual inspection: Condition of plain bearings		
	Visual inspection: Condition of shaft seal		
	Visual inspection: Condition of outboard bearings (if existing)		
<b>As required</b>	Replace: Plain bearings (only by manufacturer)	1	2
	Replace: Outboard bearing (if existing)		
	Replace: Shaft seal		
	Replace: Other seals		

## 10 Repairs

### 10.1 Safety instructions for repair

 **DANGER****Hazardous fluids!**

Danger of death when handling hazardous fluids.

1. Comply with the safety data sheets and regulations on handling hazardous fluids.
2. Collect and dispose of hazardous fluids so that no hazards arise for people or the environment.

 **DANGER****Rotating parts!**

Danger of death due to body parts, hair or clothing getting trapped or entangled.

1. Before all work, ensure that existing drives are voltage-free and pressure-free.
2. Securely prevent restarting during all work.

 **WARNING****Failure of load-carrying parts due to overload!**

Danger of injury from flying parts.

Danger of injury from spurting fluids.

1. Depressurise the device and all connection lines before doing any work.
2. Securely prevent the restoration of pressure while working on the device.

 **CAUTION****Hot surfaces!**

Burn injury to skin if touched.

1. At temperatures  $\geq 48^{\circ}\text{C}$  the device must be allowed to cool down first.

## 10.2 General

### The repairs covers:

1. Troubleshooting  
Determination of damage, pinpointing and localisation of the damage cause.
2. Elimination of damage  
Elimination of the primary causes and replacement or repair of defective components. The repair is generally made by the manufacturer.

### Repairs by manufacturer

- Before returning the device, fill in the *return notification* form. The form can be filled in online and is available as a pdf file download.



### Device contains hazardous material

If the device was operated with dangerous liquids, it must be cleaned before the return. If this should not be possible, the safety data sheet of the hazardous material is to be provided beforehand.

### Repair by equipment builder/operator

If corresponding expertise and sufficient equipment is available, the equipment builder/operator can also make the repairs. Please consult the manufacturer about this.

- If required, request spare parts lists and assembly drawings from the manufacturer.
- Use spare parts approved by the manufacturer only.
- Dispose of packing material and used parts in accordance with the local stipulations.



### Warranty

In case of improper implementation, any warranty is voided.



### Barriers and instructions

All barriers and warning signs removed during this must be attached to their original position on completing maintenance and/or repairs.



### 10.3 Detecting and eliminating failures

Failure		Potential causes	Possible measures		
1.1	<b>Increased noise</b> <i>Pump cavitation</i>	Excessive negative pressure (not complete filling of the pump)	Check suction line design Use noise-optimised pump		
		Suction line plugged	Clean the suction line		
		Suction filter plugged or too small	Clean suction filter or use a larger filter Replace filter element		
		Suction bascet plugged or too small	Clean intake strainer or dimension larger		
		Fluid temperature too low	Adjust the temperature of medium		
		1.2	<b>Increased noise</b> <i>Foaming or air in medium</i>	Pump sucks air	Check oil level in the tank Check suction line Check the shaft seal
Shaft seal defective	Replace shaft seal				
Suction connection leaking	Retighten or replace threaded connections Replace seals				
System not vented	Vent system				
Return line ends above the fluid level	Extend return line				
Heavy foaming in the system, e.g. in gears	Use noise-optimised pump				
1.3	<b>Increased noise</b> <i>Mechanical vibrations</i>			Incorrectly aligned and/or loose coupling	Correct the alignment of the coupling and secure the coupling halves
				Incorrectly and/or insufficient line fastening	Fixate lines with suitable fastening material (e.g. pipe clamps)
		Wobbling pressure relief valve (if existing)	Increase valve opening pressure		
		Not a noise-reducing setup	Use dampers		

Failure		Potential causes	Possible measures
2	Pump does not suck	Dry run	Fill pump and the suction line with medium.
		Minimum filling level in the supply tank undercut	Top up medium
		False direction of rotation of the pump	Correct the direction of rotation
		Closed shut-off element in the suction line	Open the shut-off element
		Suction line plugged	Clean the suction line
		The air in the suction line cannot be compressed in the pressure line	Reduce the start-up pressure
			Vent the pressure line
			Increase volume of the pressure line
		Speed of the pump is too low	Check the pump design
			During frequency inverter operation: Check the operation/line frequency
Geodetic suction head too high	Check installation location		
	Provide pre-filling pump		

Failure		Potential causes	Possible measures
3	<b>Insufficient pressure Insufficient pumping flow rate</b>	Excessive negative pressure (not complete filling of the pump)	Check suction line design
		Viscosity too high	Provide pre-filling pump
		Speed of the pump is too low	Check the pump design
			During frequency inverter operation: Check the operation/line frequency
		Throttled shut-off element in the suction line	Open the shut-off element
		Suction line plugged	Clean the suction line
		Suction filter plugged or too small	Clean suction filter or use a larger filter
			Replace filter element
		Suction basket plugged or too small	Clean intake strainer or dimension larger
		Constant triggering of pressure relief valve (if existing)	Increase valve opening pressure
		Pump sucks air	Check oil level in the tank
Check suction line			
Check the shaft seal			
Wear	Replace the device		
4	<b>Excessive operating temperature</b>	Cooling and heat dissipation insufficient	Increase the cooling capacity
		Not sufficient oil in the system	Check the container layout
		Excess fluid is being delivered into the supply tank via pressure relief valve under load	Check the pump design
5	<b>Impermissible pump heating</b>	Constant triggering of a directly attached pressure relief valve (if existing)	Increase valve opening pressure
		Pressure too high in association with a media viscosity that is too low	Check the system design
		Speed too fast in connection with media viscosity that is too high	Check the system design
		Gland lid overtightened (for gland seal)	Unscrew gland lid and readjust leakage
		Suction pressure too high	Reduce the pressure
		Wear	Replace the device

Failure		Potential causes	Possible measures
<b>6</b>	<b>Leakages</b> <i>Seal failure</i>	Poor maintenance	Comply with maintenance plan Replace seals
		Mechanical damage	Replace seals
		Thermal overload	Check the operating datas Replace seals
		Pressure too high	Check the operating datas Replace seals
		Gas content in medium too high	Check the operating datas Replace seals
		Corrosion/chemical impact	Check the material compatibility Replace seals
		Wrong direction of rotation	Correct the direction of rotation Replace seals
		Contaminated medium	Provide filtration Replace seals
		Gland lid not sufficiently tightened (for gland seal)	Retighten gland lid
		Loose threaded connections	Retighten or replace threaded connections
<b>7.1</b>	<b>Coupling</b> <i>Coupling wear</i>	Alignment error	Correct the alignment of the coupling and secure the coupling halves
		Spider overloaded	Check the operating datas Use harder spider
<b>7.2</b>	<b>Coupling</b> <i>Cam break</i>	Spider wear Torque transmission due to metal contact	Adapt maintenance intervals Replace coupling
<b>7.3</b>	<b>Coupling</b> <i>Premature spider wear</i>	Alignment error	Correct the alignment of the coupling and secure the coupling halves Replace spider
		Spider failure due to chemical corrosion	Check the material compatibility Replace spider

Failure		Potential causes	Possible measures
8	Motor protection switch tripped	Driving power too low	Check the drive design
		Motor incorrectly connected	Check motor connection
		Phase failure	Check feed/supply
		Current consumption too high	Check the operating datas
			Check direction of rotation
Motor circuit breaker incorrectly designed	Check the operating datas		
<b>Consult the manufacturer for all unidentifiable failures.</b>			