

KRACHT

D.0025490002

Operating instructions (Translation)

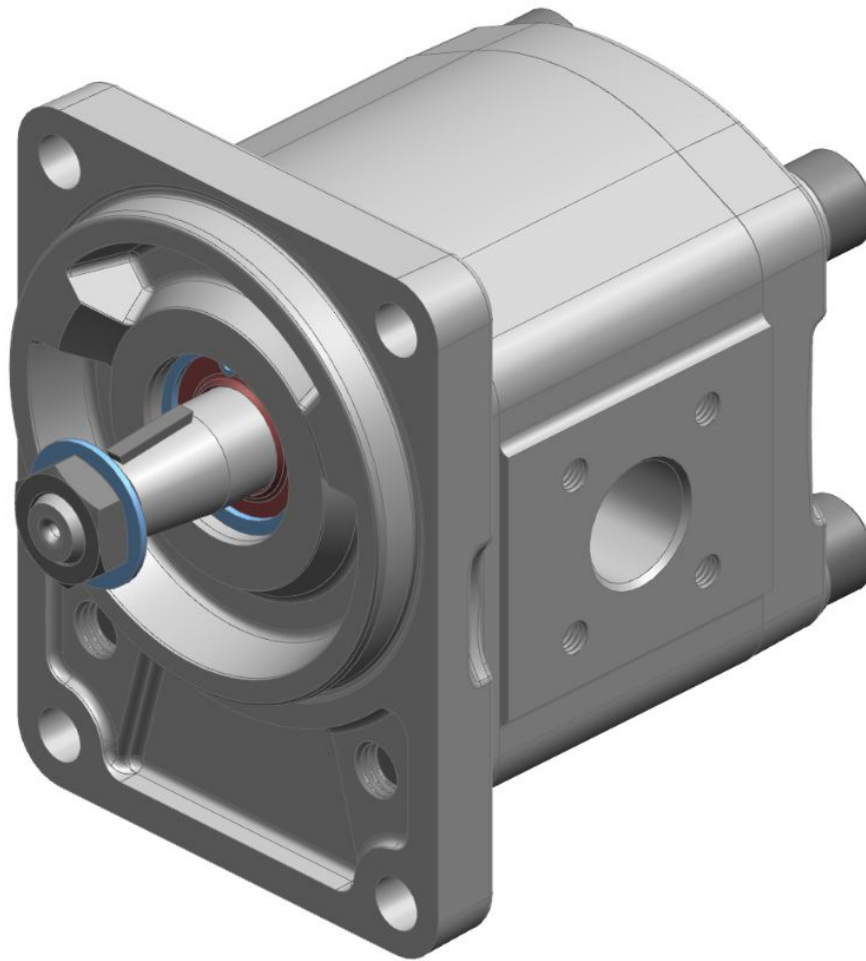

High pressure gear pump KP 1/.
English

Table of content

1	General	4
1.1	About the documentation	4
1.2	Manufacturer address.....	4
1.3	Applicable documents.....	4
1.4	Symbols.....	5
2	Safety.....	6
2.1	Intended use.....	6
2.2	Personnel qualification and training.....	6
2.3	Basic safety instructions.....	7
2.4	Fundamental hazards.....	7
3	Device description.....	9
3.1	Functional principle	9
3.2	Possible versions.....	10
3.3	Type key	11
3.4	Rotation and delivery direction	12
3.5	Types of seals.....	13
3.6	Special numbers.....	13
3.7	Shaft ends.....	14
4	Technical data.....	16
4.1	General	16
4.2	Nominal sizes.....	17
4.3	Permissible radial force	18
4.4	Permissible pressure range.....	19
4.4.1	Operating pressure at suction side.....	19
4.4.2	Operating pressure at pressure side	19
4.5	Permissible temperature range.....	20
4.6	Material data	20
4.7	Weight	20
4.8	Dimensions	21
5	Transport and storage	22
5.1	General	22
5.2	Transport.....	22
5.3	Storage	22
5.4	Storage conditions.....	23
6	Installation	24
6.1	Safety instructions for installation	24
6.2	Noise reduction.....	25

6.3	Mechanical installation.....	25
6.3.1	Preparation.....	25
6.3.2	Gear Pump with free shaft end.....	26
6.4	Connection lines	27
6.4.1	General.....	27
6.4.2	Suction line.....	28
6.4.3	Pressure line.....	29
6.4.4	Mounting Connection lines	29
6.5	Change of the direction of rotation	29
7	Operation start-up	30
7.1	Safety instructions for start-up	30
7.2	Preparation.....	30
7.3	Further operation start-up.....	31
8	Removal.....	32
8.1	Safety instructions for removal	32
8.2	Removal.....	33
9	Maintenance	34
9.1	Important notes about explosion protection	34
9.2	Maintenance work.....	35
9.3	Maintenance instructions.....	35
9.4	Maintenance table	36
	Maintenance table.....	36
9.4.1	Inspection: Discharge flow	37
9.4.2	Inspection: Operating pressure	37
9.4.3	Inspection: Media temperature	37
9.4.4	Inspection: Device temperature	37
9.4.5	Inspection: Add-on valve function (if existing).....	37
9.4.6	Inspection: Check the potential compensation (if existing)	37
9.4.7	Inspection: Condition of operating fluid	37
9.4.8	Audiometric monitoring: Unusual noise.....	37
9.4.9	Cleaning.....	38
9.4.10	Visual inspection: Leakages	38
9.4.11	Visual inspection: Condition gears.....	38
9.4.12	Visual inspection: Condition of housing parts.....	38
9.4.13	Visual inspection: Condition of plain bearings.....	38
9.4.14	Visual inspection: Condition of shaft seal	38
9.4.15	Visual inspection: Condition of outboard bearings.....	38
9.4.16	Replacing: Outboard bearings.....	39
9.4.17	Replacing: Plain bearings (only by manufacturer)	39
9.4.18	Replacing: Shaft seal.....	39
9.4.19	Replacing: Other seals.....	39
10	Repairs	40
10.1	Safety instructions for repair.....	40
10.2	General	41
10.3	Detecting and eliminating failures.....	42

1 General

1.1 About the documentation

These operating instructions describe the installation, operation and maintenance of the following device:

High pressure gear pump KP 1

These operating instructions are a component of the device and must be kept accessible for the personnel near the device at all times.

The device is manufactured in different versions. Information about the version concerned in the individual case can be found on the device's type plate.

If you have any questions about these operating instructions, please contact the manufacturer.

1.2 Manufacturer address

KRACHT GmbH
Gewerbestraße 20
DE 58791 Werdohl
Tel: +49 2392 935-0
Fax: +49 2392 935-209
E-Mail: info@kracht.eu
Web: www.kracht.eu

1.3 Applicable documents

In addition to these instructions, also observe the corresponding instructions for the existing or planned systems or system parts.

1.4 Symbols



DANGER

Identification of an immediate hazard, which would result in death or severe bodily injury if not avoided.



WARNING

Identification of a potential medium risk hazard, which would lead to death or severe bodily injury if not avoided.



CAUTION

Identification of a low risk hazard, which could lead to minor or medium bodily injury if not avoided.

ATTENTION

Flagging of notices to prevent property damage.



NOTICE

Identification of basic safety instructions.
Non-compliance can lead to hazards for people and the device.



TIP

Flagging of special user tips and other especially useful or important information.

2 Safety

2.1 Intended use

1. The device has been designed for operation with fluid.
Dry operation is not permitted.
2. The product may only be operated when completely filled.
3. The fluid must be compatible with the materials used in the product. Chemical expertise is required for that. Be careful with ethylene oxide or other catalytically or exothermically reacting or self-decomposing substances. Please consult the manufacturer in cases of doubt.
4. The product may only be used in normal industrial atmospheres.
If there are any aggressive substances in the air, always consult the manufacturer.
5. The product may only be operated in compliance with these operating instructions and the applicable documents.
Deviating operating conditions require the express approval of the manufacturer.
6. Use of the product for purposes other than those for which it is intended invalidates any warranty.

2.2 Personnel qualification and training

The personnel designated to assemble, operate and service the device must be properly qualified.

This can be through training or specific instruction.

Personnel must be familiar with the contents of this operating instructions.



NOTICE

Read the operating instructions thoroughly before use.

2.3 Basic safety instructions



NOTICE

Basic safety instructions

Non-compliance can lead to hazards for people and the unit.

- a) Follow existing regulations for accident prevention and safety at work as well as the internal regulations of the operating company.
- b) Ensure the greatest possible cleanliness.
- c) Wear suitable personal protective equipment.
- d) Do not remove type plates or other information or make them illegible or unrecognisable.
- e) Do not make any technical modifications.
- f) Comply with maintenance intervals.
- g) Only use spare parts approved by the manufacturer.

2.4 Fundamental hazards



DANGER

Hazardous fluids

Danger to life when handling hazardous fluids.

- a) Comply with the safety data sheets and regulations on handling the hazardous fluids.
- b) Collect and dispose of hazardous fluids so that no hazard is created for persons or the environment.



DANGER

Hazardous fluids

Danger to life when handling hazardous fluids.

- a) Defective components and connection lines must be replaced or fixed without delay.
- b) Use only components and connection lines approved for the expected pressure range.



DANGER

Rotating parts!

Danger of death due to body parts, hair or clothing getting trapped or entangled.

- a) Before all work, ensure that existing drives are voltage-free and pressure-free.
- b) Securely prevent restarting during all work.



⚠ DANGER

Rotating parts

Danger of death due to body parts, hair or clothing getting trapped or entangled.

- a) Take measures against accidental touching of rotating parts.



⚠ WARNING

Rotating parts!

Danger of injury from flying parts.

- a) Enclose rotating parts so as to avoid any danger from flying parts in the event of breakage or malfunction.



⚠ WARNING

Failure of pressure bearing parts due to overload

Risk of injury from flying parts.

Risk of injury due to splashing fluids.

- a) Depressurize the system before all work.
- b) Securely prevent the pressure from being restored during work.



⚠ WARNING

Failure of pressure bearing parts due to overload

Risk of injury from flying parts.

Risk of injury due to fluid spurting out.

- a) Use only connections and lines approved for the expected pressure range.
- b) Securely prevent the permissible pressures from being exceeded, e.g. by using pressure relief valves or bursting discs.
- c) Pipelines must be designed in such a way that no tension e.g. caused by changes in length due to fluctuations in temperature can be transferred to the product.



⚠ WARNING

Failure of pressure bearing parts due to overload

Risk of injury from flying parts.

Risk of injury due to fluid spurting out.

- a) Do not operate the product with shut-off devices closed.
- b) Securely prevent the restoration of pressure while working on the device.

3 Device description

3.1 Functional principle

Pumps of this series are external gear pump types that work according to the positive displacement principle.

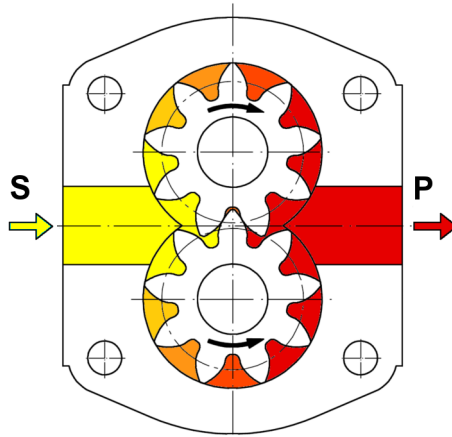

- S Suction connection
- P Pressure connection

When rotated, two gearwheels meshing together produce a volume enlargement as a result of the opening of the tooth spaces on the suction side (S), so that medium can flow in and so that a corresponding volume is displaced simultaneously by immersion of the teeth into the filled tooth spaces on the pressure side (P). Fluid transport takes place through entrainment in the tooth gaps along the wall of the wheel chamber. The so-called geometric flow rate V_g is being displaced per wheel rotation. A value that is stated in technical documents as the V_{gn} to specify the unit size.

The displacement cycle describe initially takes place without exhibiting appreciable pressure build-up. Only after setting external loads, for example, through delivery heights, flow resistances, line elements, etc. will the required working pressure arise to overcome these resistances.

The pressure occurring at the shaft seal therefore corresponds to the pressure at the suction connection of the device. The permissible pressure is determined by the type of sealing.

According to its design, this external gear pumps are classified as so-called gland-type bearing pumps.

All the essential functional elements, gearing and gland bearings are located in an aluminium housing made of high-strength extrusion alloy closed on each side by the end cover or flange cover (cast iron). The gearing made of case-hardened steel with surface hardening consists of the driving shaft pinion and the driven shaft pinion.

The gland bearings located on both sides of the gearing support the shaft journals and sealing elements in heavy-duty multi-component plain bearings which are used for pressure field sealing to compensate axial clearance.

3.2 Possible versions

Gear pump

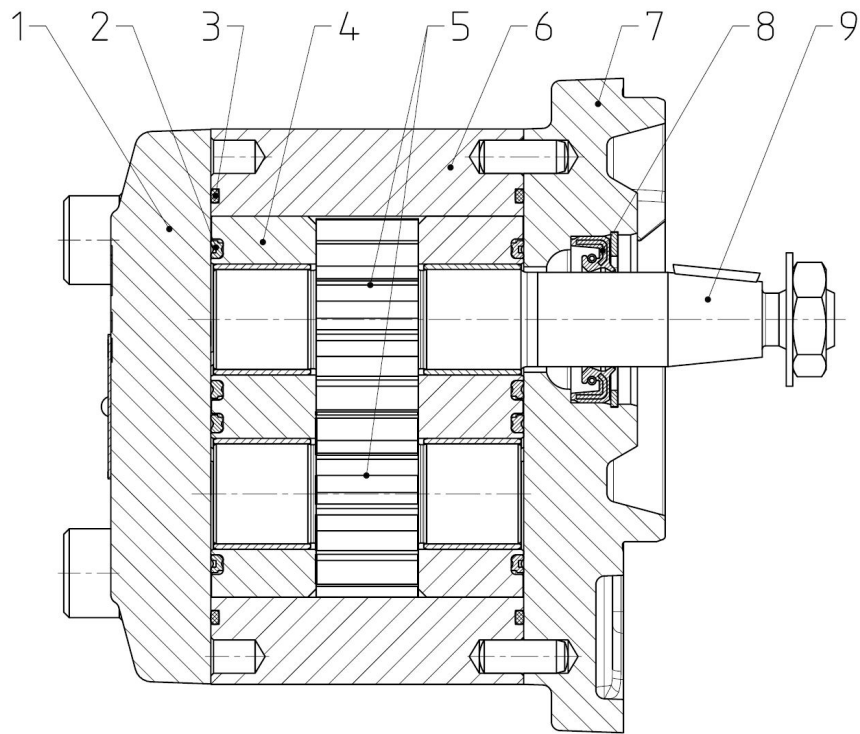

- | | |
|----------------------|---|
| 1 End cover | 2 Seal |
| 3 O-ring | 4 Gland bearing with multilayer friction bearings |
| 5 Gears | 6 Housing |
| 7 Flange cover | 8 Shaft seal |
| 9 End of drive shaft | |

Multi-stage version

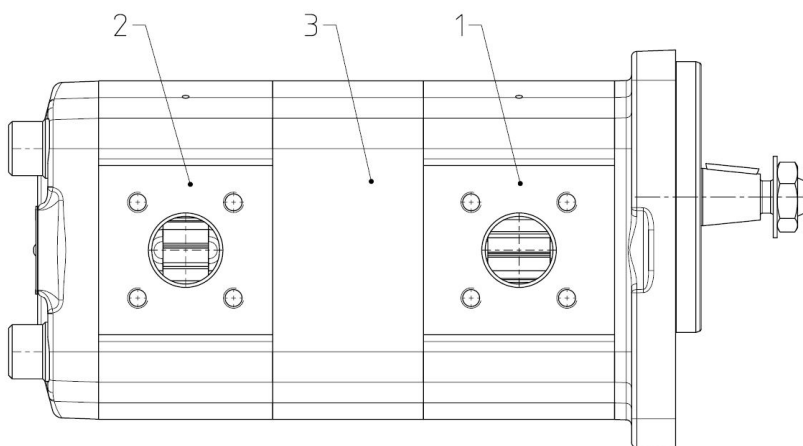

- | | |
|----------------|----------------|
| 1 First stage | 2 Second stage |
| 3 Pipe adaptor | |

3.3 Type key

Ordering example																		
KP		1/	8		G	1	0	A		K	0	A		4	N	L	1	/...
1.		2.	3.		4.	5.	6.	7.		8.	9.	10.		11.	12.	13.	14.	15.
Explanation of type key																		
1. Product name																		
2. Size																		
1																		
3. Nominal size																		
V_{gn}		2; 3; 4; 5.5; 6.3; 8; 11; 12,5; 14; 16; 19; 22; 25																
4. Flange mounting cover																		
A		SAE-A-2-hole flange					L		Square 2-hole flange with O-ring (Without shaft seal)									
F		Square 2-hole flange					M		See F; but with attachment bore holes mirrorinverted									
G		Rectangular 4-hole flange					Q		Square 2-hole flange with O-ring									
K		Rectangular 4-hole flange																
5. Direction of rotation																		
1		Clockwise					2		Counterclockwise									
6. Outboard flange / Outbord bearing																		
0		Without					P		Outbord bearing , heavy-duty version									
L		Outbord bearing , Light-duty design					R		Attachment angle									
7. Construction of housing																		
A		Bolt circle					U		Bolt circle									
Q		Bolt circle																
8. Driving shaft																		
F		Flat plug ($M_{max} = 40 \text{ Nm}$)					S		gear shaft profile ($M_{max} = 55 \text{ Nm}$)									
K		Cone 1:5 ($M_{max} = 160 \text{ Nm}$)					X		gear shaft profile ($M_{max} = 70 \text{ Nm}$)									
M		Cone 1:8 ($M_{max} = 160 \text{ Nm}$)					S + Special number 336		gear shaft profile ($M_{max} = 95 \text{ Nm}$)									
9. 2nd shaft end																		
0		Without 2nd shaft end					X		gear shaft profile									
10. End cover (Pipe adaptor)																		
A		End cover					F		Pipe adaptor									
11. Design serial number (specified by manufacturer)																		

Explanation of type key			
12. Housing material and plain bearing			
N	Housing material Al Mg Si 1 Cu Gland bearing with mul- tilayer friction bearings	V	Housing material EN- GJS-600 (GGG-60) Gland bearing with multilayer fric- tion bearings
13. Gears version			
L	Driving shaft and driven shaft are made of case-hardened steel, milled tooth flanks		
14. Seal type			
1	Rotary shaft seal NBR	2	Rotary shaft seal FKM
15. Special number			
Special numbers [► 13]			

3.4 Rotation and delivery direction

The direction of rotation is indicated by the bent arrow, Looking at the end of drive shaft. The pump connections are below the drive shaft.

The flow direction is indicated by the straight arrows.

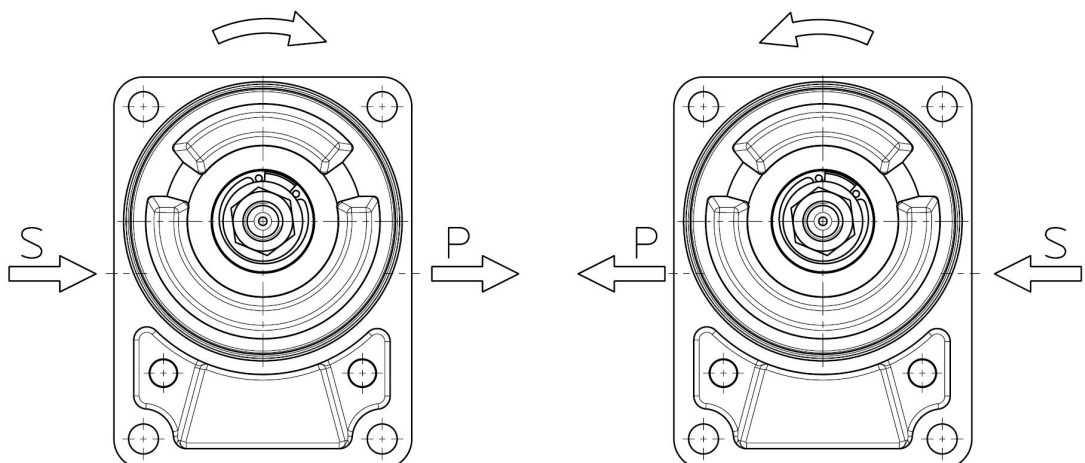

S = Suction connection

P = Pressure connection

3.5 Types of seals

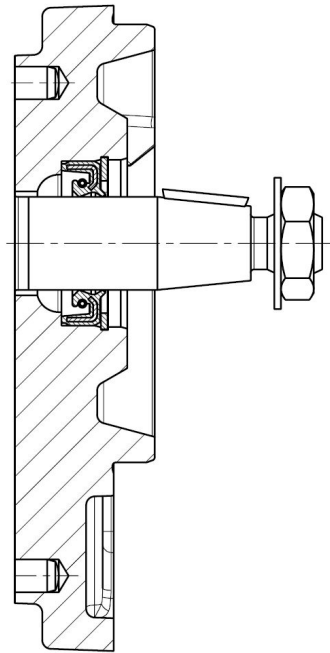

Rotary shaft seal
Seal type : 1; 2

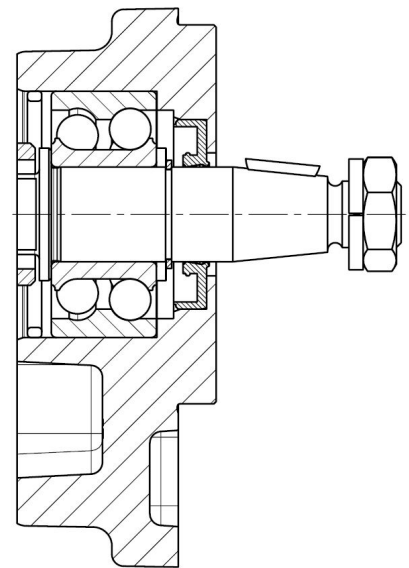

Rotary shaft seal with Outbord bearing
Light-duty design
Seal type : 1; 2

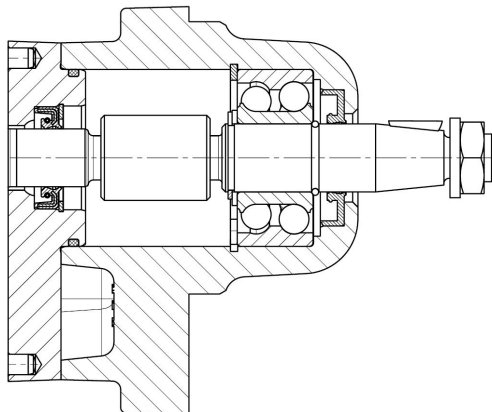

Rotary shaft seal with Outbord bearing ,
heavy-duty version
Seal type : 1; 2

3.6 Special numbers

250	Flange cover with o-ring notch in the centring
271	Multi-stage version
336	Strengthened shaft end
340	Special short construction type with profile pin connection

3.7 Shaft ends

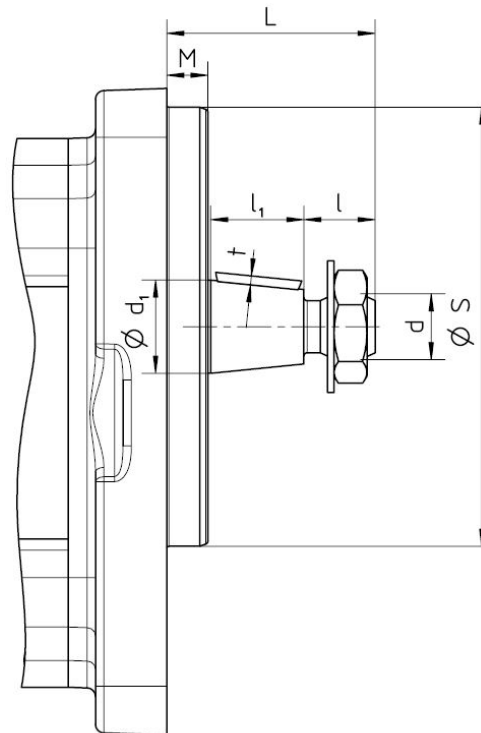

Flange cover	Driving shaft	L	S	M	Cone	d	d ₁	l	l ₁	t
G	K	38	80	7.5	1:5	M12x1.5	17	13	17	1.5
A	K		82.55	6.35						
K	M	39.5	36.47	4.8	1:8			12.1	18.2	
F	K	40.5	50	7.2	1:5			13	17	
M	K									
Q	K		52							

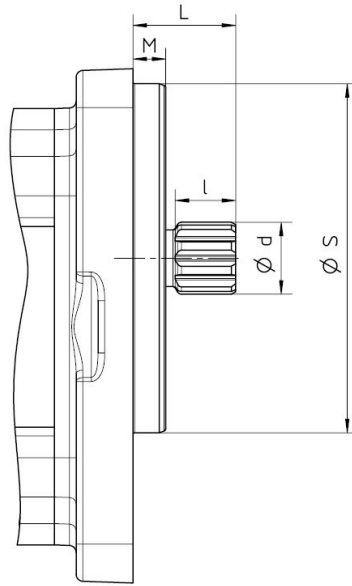

Flange cover	Driving shaft	L	S	M	Profile	DIN	Diametral pitch (DP)	Number of teeth	d _{h11}	l
A	S	31.7	82.55	6.35	SAE A		16/32	9	15.46	16
G	X	23.5	80	7.5	B17x14	5482	-		16.5	14
A	X		82.55	6.35						
K	X	22	36.47	4.8						
F	X	26	50	7.2						
M	X									
Q	X									
L	X	-	52							

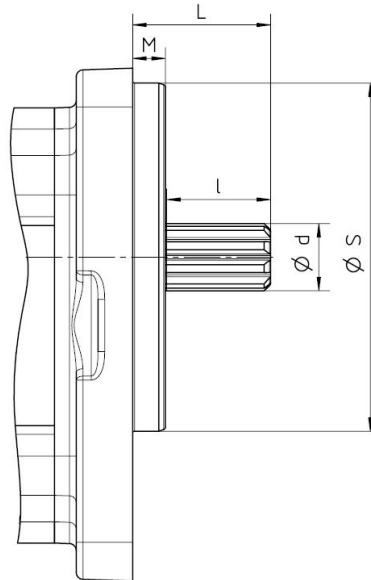

Flange cover	Driving shaft	Special number	L	S	M	Profile	Diametral pitch (DP)	Number of teeth	d _{-0.13}	l
A	S	336	31.7	82.55	6.35	SAE A	16/32	9	15.46	23.9

4 Technical data

4.1 General

General information				
Housing connection	A	KP 1/2	Suction connection : Ø15/LK35	
		KP 1/3 - KP 1/5.5	Suction connection : Ø15/LK40	
		KP 1/6.3 - KP 1/25	Suction connection : Ø20/LK40	
	Q	KP 1/2 - KP 1/8	Suction connection : Ø13.5/LK30.2	Pressure connection : Ø13.5/LK30.2
		KP 1/11 - KP 1/25	Suction connection : Ø20/LK39.7	
	U		Suction connection : Without	Pressure connection : Ø15/LK35
Flange mounting cover	A	LA= 106.4; ØZ= 82.55		
	F	LA= 60/60; ØZ= 50		
	G	LA= 72/100; ØZ= 80		
	K	LA= 71.4/96.1; ØZ= 36.47		
	L	LA= 60/60; ØZ= 52		
	M	LA= 60/60; ØZ= 50		
	Q	LA= 60/60; ØZ= 52		
LK= Bolt circle; LA= Hole distance ; Z= Centering diameter				
Mounting position		Any		
External loads on shaft end	F_{axial}	Axial forces are not permissible.		
	F_{radial}	Axial and radial forces are only permissible in combination with an outboard bearing. Permissible radial force [▶ 18]		
Speed	n	Nominal sizes [▶ 17]		
Operating pressure	p_e	Permissible pressure range [▶ 19]		
	p_b			
Viscosity range	permissible in continuous operation	v_{min}	10 mm ² /s	
		v_{max}	600 mm ² /s	
	recommended for continuous operation	v_{min}	30 mm ² /s	
		v_{max}	45 mm ² /s	
Fluid temperature	ϑ_m	Permissible temperature range [▶ 20]		
	ϑ_u	Permissible temperature range [▶ 20]		

General information		
Filtering	β	$\beta_{25} \geq 75$ for ... 300 bar
		$\beta_{40} \geq 75$ for ... 100 bar
Permissible media		Mineral oil according to DIN 51524/25 Motor oil according to DIN 51511 Bio-oils of the "HEES" group can be used up to 70 °C and at maximum pressure reduced by about 20 %



TIP

A reduced service life must be expected for the shaft seal in the case of vertical installation (shaft end top).

4.2 Nominal sizes

Nominal size V_{gn}	Geom. displacement V_g [cm ³ /rev.]	Speed n_{max} [rpm]	Minimum speeds n_{min} [rpm]						Mass inertia x 10^{-6} J [kg m ²]					
			at p = ...bar											
			100	120	150	180	200	250						
2	2	4000	600	700	900	1200	1300	1400	19.7					
3	3					1200	1300		23.3					
4	4					1200	1300		28.4					
5.5	5.45		3500	500	700	900	1200	1100	1200	35.7				
6.3	6.28						1200			1100	39.9			
8	7.9						1000			1100	51.1			
11	10.9	1100					1200			62.9				
12.5	12.43	1200					1200			71.6				
14	13.85	3000	500	700	800	900	1000	1000	77.7					
16	15.9				1000	1000			87.7					
19	18.8	2800	600	700	800	-	-	-	102.5					
22	22.3	2500							-	-	-	-	-	119.6
25	25.21													135.3

4.3 Permissible radial force

Version with outboard bearing, Light-duty design

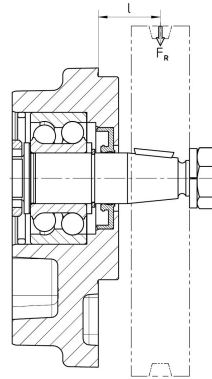

perm. radial force F_R [N] ⁽¹⁾				
Bracing distance l [mm] 21.5 Centre shaft	Speed n [rpm]			
	1000	2000	3000	4000
0	1500	1300	1100	900
10	1200	900	700	650
20	850	700	650	600
30	700	600	500	450
40	600	500	450	400
50	550	450	400	350

⁽¹⁾ related to a bearing service life $LH = 10.000$ h

Version with outboard bearing, heavy-duty version

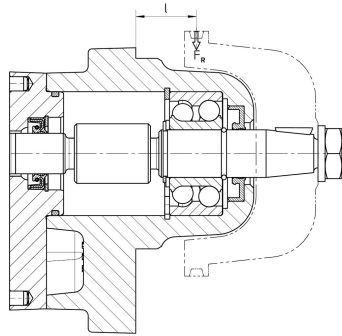

perm. radial force F_R [N] ⁽¹⁾				
Bracing distance l [mm] 38 Centre shaft	Speed n [rpm]			
	1000	2000	3000	4000
0	2700	2200	1800	1700
10	1650	1400	1300	1200
20	1300	1050	900	750
30	1000	700	650	600
40	700	600	550	450
50	600	550	450	400
60	550	450	400	350

⁽¹⁾ related to a bearing service life $LH = 10.000$ h

4.4 Permissible pressure range

4.4.1 Operating pressure at suction side

Speed n [1/min]	Operating pressure			
	suction side			
	$p_{e\ min}$ [bar abs.]	$p_{e\ max}$ [bar rel.]	$p_{e\ min}$ [bar abs.]	$p_{e\ max}$ [bar rel.]
	FKM		NBR	
250	0.6	30	0.6 ⁽¹⁾	10
500		27		9
1000		22		7
1500		18		6
2000		14		4.5
2500		12		4
3000		9		3.0
3500		7		2.7
4000		6		2.5

4.4.2 Operating pressure at pressure side

Nominal size V_{gn}	Operating pressure		
	pressure side		
	p_{max} [bar rel.] (Maximum pressure)	p_N [bar rel.] (Nominal pressure)	p_D [bar rel.] (Permanent pressure)
2	300	280	250
3			
4			
5.5			
6.3			
8			
11			
12.5			
14			
16			
19	250	230	200
22	200	180	150
25			

4.5 Permissible temperature range

Sealing material	Fluid temperature ϑ_m	
	$\vartheta_{m \min}$ [°C]	$\vartheta_{m \max}$ [°C]
FKM / P5000	-20	100
NBR / P5000		90

Sealing material	Ambient temperature ϑ_u	
	$\vartheta_{u \min}$ [°C]	$\vartheta_{u \max}$ [°C]
FKM	-20	60
NBR		



NOTICE

Comply with media-specific properties

4.6 Material data

Seal type	Material						
	Shaft seal	O-ring	Housing	End cover / Flange cover	Gears	Bearing	Seal Pressure fields
1	NBR	NBR	Aluminium	EN-GJS-400-15 (GGG-40)	Case-hardened steel (Steel 1.7139)	Multi layer friction bearings contains lead	P5000 (TPU)
2	FKM	FKM	--- EN-GJS-600 (GGG-60)				

4.7 Weight

Housing material Aluminium					
Nominal size V_{gn}	Gear pump [kg]				
	Flange mounting cover				
	A / G	K	F / M / Q ⁽¹⁾	L ⁽²⁾	F with Attachment angle
2	3.0	2.4	2.6	2.5	4.2
3	3.1	2.5	2.7	2.6	4.3
4	3.2	2.6	2.8	2.7	4.4
5.5					

Housing material Aluminium					
Nominal size V_{gn}	Gear pump [kg]				
	Flange mounting cover				
	A / G	K	F / M / Q ⁽¹⁾	L ⁽²⁾	F with Attach- ment angle
6.3	3.3	2.7	2.9	2.8	4.5
8					
11	3.5	2.9	3.1	3.0	4.7
12.5					
14	3.6	3.0	3.2	3.1	4.8
16	3.8	3.2	3.4	3.2	5.0
19	3.9	3.3	3.5	3.4	5.1
22	4.1	3.5	3.7	6.3	5.3
25	4.3	3.7	3.9	3.8	5.5

⁽¹⁾ + 3.5 kg with outboard bearing
⁽²⁾ + 1.1 kg with outboard bearing

Housing material EN-GJS-600 (GGG-60)					
Nominal size V_{gn}	Gear pump [kg]				
	Flange mounting cover				
	A / G	K	F / M / Q ⁽¹⁾	L ⁽²⁾	F with Attach- ment angle
2	4.0	3.4	3.6	3.5	5.2
3	4.1	3.5	3.7	3.6	5.3
4	4.2	3.6	3.8	3.7	5.4
5.5	4.3	3.7	3.9	3.8	5.5
6.3	4.4	3.8	4.0	3.9	5.6
8	4.5	3.9	4.1	4.0	5.7
11	4.8	4.2	4.4	4.3	6.0
12.5					
14	5.0	4.4	4.6	4.5	6.2
16	5.3	4.7	4.9	4.8	6.5
19	5.5	4.9	5.1	5.0	6.7
22	5.7	5.1	5.3	5.2	6.9
25	6.1	5.5	5.7	5.6	7.3

⁽¹⁾ + 3.5 kg with outboard bearing
⁽²⁾ + 1.1 kg with outboard bearing

4.8 Dimensions

Dimensions of the device can be found in the relevant technical data sheets.

5 Transport and storage

5.1 General

- a) After receipt, check the device for transport damages.
- b) If transport damage is noticed, report this immediately to the manufacturer and the carrier. The device must then be replaced or repaired.
- c) Dispose of packing material and used parts in accordance with the local stipulations.

5.2 Transport



WARNING

Falling or overturning loads!

Danger of injury while transporting large and heavy loads.

- a) Use only suitable means of conveyance and lifting tackle with sufficient load-bearing capacity.
- b) Attach lifting tackle only to suitable load points.
- c) Attach the lifting tackle in such a manner that it cannot slip.
- d) Pay attention to the load balance point.
- e) Always avoid jerks, impacts and strong vibrations during transportation.
- f) Never walk under suspended loads, never work under suspended loads.



NOTICE

To transport the device, eyebolts can be screwed into the flange connections..

5.3 Storage

The device's function is tested in the plant with mineral hydraulic oil. Then all connections are closed. The remaining residual oil preserves the interior parts for up to 6 months.

Metallic exposed exterior parts are protected against corrosion by suitable conservation measures, also up to 6 months.

In case of storage, a dry, dust-free and low-vibration environment is to be ensured. The device is to be protected against influences from weather, moisture and strong fluctuations of temperature. The recommended storage conditions are to be adhered to.

Below the permissible ambient temperature ϑ_U elastomer seals lose their elasticity and mechanical loading capacity, since the glass transition temperature is fallen below. This procedure is reversible. A force action on the device is to be avoided in case of storage below the permissible ambient temperature ϑ_U .

Devices with EPDM seals are not mineral-oil resistant and are not tested for their function. There is no preservation of the interior parts. If the device is not taken into operation immediately, all corrosion-prone surfaces are to be protected by suitable conservation measures. The same applies for devices which are not tested for other reasons

When storing for a long period of time (> 6 months), treat all surfaces at risk of corrosion again with suitable preserving agents.

If high air humidity or aggressive atmospheres are expected, take additional corrosion-preventing measures.



NOTICE

Storage in corrosion protection bags (VCI) maximum of 6 months.

⚠ ATTENTION

Corrosion/chemical impact

Improper storage can render the device useless.

- a) Protect endangered surfaces by means of suitable conservation measures.
- b) Comply with recommended storage conditions.

5.4 Storage conditions



TIP

Recommended storage conditions

- a) Storage temperature: 5 °C – 25 °C
- b) Relative air humidity: < 70 %
- c) Protect elastomer parts from light, especially direct sunlight.
- d) Protect elastomer parts from oxygen and ozone.
- e) Comply with maximum storage times of elastomeric parts:
 - ⇒ 5 Years: AU (Polyurethane rubber)
 - ⇒ 7 Years: NBR, HNBR, CR
 - ⇒ 10 Years: EPM, EPDM, FEP/PFTE, FEPM, FKM, FFKM, VMQ, FVMQ

6 Installation

6.1 Safety instructions for installation



⚠ DANGER

Hazardous fluids

Danger to life when handling hazardous fluids.

- a) Comply with the safety data sheets and regulations on handling the hazardous fluids.
- b) Collect and dispose of hazardous fluids so that no hazard is created for persons or the environment.



⚠ DANGER

Rotating parts!

Danger of death due to body parts, hair or clothing getting trapped or entangled.

- a) Before all work, ensure that existing drives are voltage-free and pressure-free.
- b) Securely prevent restarting during all work.



⚠ DANGER

Rotating parts

Danger of death due to body parts, hair or clothing getting trapped or entangled.

- a) Take measures against accidental touching of rotating parts.



⚠ WARNING

Rotating parts!

Danger of injury from flying parts.

- a) Enclose rotating parts so as to avoid any danger from flying parts in the event of breakage or malfunction.



⚠ WARNING

Unshielded gearwheels

Gearwheels can trap and crush fingers and hands.

- a) Do not engage gearwheels.



⚠ WARNING

Failure of load-carrying parts due to overload!

Danger of injury from flying parts.
 Danger of injury from spurting fluids.

- a) Depressurise the device and all connection lines before doing any work.
- b) Securely prevent the restoration of pressure while working on the device.



⚠ WARNING

Failure of pressure bearing parts due to overload

Risk of injury from flying parts.
 Risk of injury due to fluid spurting out.

- a) Use only connections and lines approved for the expected pressure range.
- b) Securely prevent the permissible pressures from being exceeded, e.g. by using pressure relief valves or bursting discs.
- c) Pipelines must be designed in such a way that no tension e.g. caused by changes in length due to fluctuations in temperature can be transferred to the product.

6.2 Noise reduction



TIP

Measures for noise reduction

- a) Use suction and pressure hoses.
- b) Use bell housings with high damping properties (plastic or cast iron).
- c) Use of damping rings and damping rods for separation of structureborne noise.

6.3 Mechanical installation

6.3.1 Preparation

- a) Check the device for transport damage and dirt.
- b) Check the device for freedom of movement.
- c) Remove existing preservatives.
 - ⇒ Use only those cleaning agents that are compatible with the materials used in the device.
 - ⇒ Do not use cleaning wool.
- d) Compare the environmental and ambient conditions at the place of installation to the permissible conditions.
 - ⇒ Ensure a sufficiently stable and level foundation.

- ⇒ Expose the device only to small vibrations, see IEC 60034-14.
- ⇒ Secure sufficient access for maintenance and repair.
- e) Position the product and secure them against slipping.
 - ⇒ Comply with the manufacturer's information.
 - ⇒ Do not use any sealing materials such as hemp, Teflon tape or putty.

6.3.2 Gear Pump with free shaft end

The prerequisite for trouble-free operation is suitable load transmission between the pump and the drive.

By default a torsionally flexible claw coupling is used for this.

- a) Position the pumps and the drive with respect to each other.
 - ⇒ Comply with the permissible mounting position.
 - ⇒ Comply with the permissible direction of rotation.
- b) Tighten all fastening screws with the specified torque.



⚠ DANGER

Rotating parts

Danger of death due to body parts, hair or clothing getting trapped or entangled.

- a) Take measures against accidental touching of rotating parts.



⚠ CAUTION

Hot surfaces

Burn injury to skin if touched.

- a) Wear protective gloves at temperatures ≥ 48 °C.

Tightening torques [Nm]							
Thread size	M6	M8	M10	M12	M16	M20	M24
Counter-thread Aluminium	4.6	11	22	39	95	184	315
Counter-thread Cast iron / Steel	10	25	49	85	210	425	730

⁽¹⁾ Screws/Nuts with min. strength class 8.8/8



TIP

- a) Keep to the permissible displacement values of the coupling.
- b) Rule out any distortion of the device.
- c) Pay attention to sufficient screw-in depth of the fastening screws.



NOTICE

- a) For devices without shaft seals, ensure that the leak oil from the shaft sealing chamber is specifically drained off and cannot get into the environment.
- b) Make sure no foreign bodies can get into the device.
- c) On devices with quench, mount a tank for the liquid seal.
 - ⇒ Mount the tank above the device.
 - ⇒ The connection on the device must point upward.
 - ⇒ Checking the fluid level must be possible at any time.

6.4 Connection lines

6.4.1 General



WARNING

Failure of load-carrying parts due to overload

Danger of injury from flying parts.
 Danger of injury from spurting fluids.

- a) Use only connections and lines approved for the expected pressure range.
- b) Securely prevent exceeding the permissible pressure, e.g. by using pressure relief valves or rupture discs.
- c) Design pipework so that no tensions, e.g. caused by changes in length due to fluctuations in temperature, are transmitted to the device.



NOTICE

Additional connections

- a) Provide measurement connections for pressure and temperature as close as possible to device.
- b) If necessary, provide a facility to fill or empty the device and the line system.
- c) If necessary, provide a facility to vent the device and the line system.

6.4.2 Suction line

A less than optimally planned suction line can lead to increased noise emission, cavitation as well as reduction of the delivery rate (caused by not complete filling of the pump).

When designing the line, take the following points into consideration:

- The suction line must be piped as short as possible and in a straight line.
- Stipulate the nominal width of the suction line so that the permissible operating pressure $p_{e\ min}$ is not exceeded on the suction side.
- Avoid large suction heights.
- Avoid additional pressure loss through line resistances such as fittings, screwed connections, formed parts or suction filters/suction baskets. Ensure that all technically required suction filters/suction baskets are appropriately dimensioned.
- Make sure there is sufficient clearance of the suction port to the bottom and walls of the media container.
- Make sure that the suction opening lies underneath the lowest fluid level in all operating situations.
- When hose lines are used, ensure sufficient stability of the hoses so that they cannot become constricted through the sucking action.
- Comply with the recommended flow velocity in the suction line (max. 1.5 m/s).



NOTICE

Cavitation damage

Undercutting the permissible suction port pressure results in cavitation.

- a) Design the suction line so that the pressure arising in operation on the suction side is always higher than the vapour pressure of the pumped medium. At the same time, comply with the installation altitude of the device above mean sea level.
- b) For aqueous fluids, mount the device underneath the fluid level, set the operating temperature to 50 °C and limit the speed to 1500 rpm.

Prevention of suction problems

If there is a possibility that the suction line can run dry if the pump stops, piping the suction line as siphon is an option to avoid suction problems. This way, the pump will remain permanently filled after initial commissioning.

It is appropriate to employ a foot valve or a non-return valve in case of longer suction lines that can run dry while the pump is at rest. These must have been designed for use in suction lines and should offer as low a flow resistance as possible.

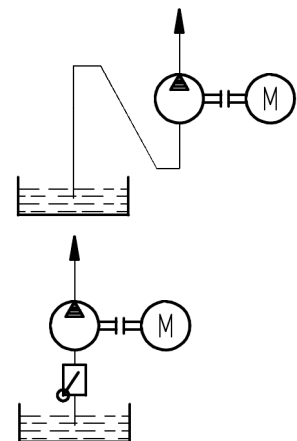

During operation of a pump that has to pump media via a non-return valve in a pressurized circuit (e.g. reserve pump in a lubricant circuit), suction problems can occur if the suction line is filled with air.

In this case the pressure pipe must be bled directly upstream of the non-return valve.

If no vent nozzle is used, the volume of the pressure pipe between the pump and the non-return valve must be at least 75 % of the suction line volume.

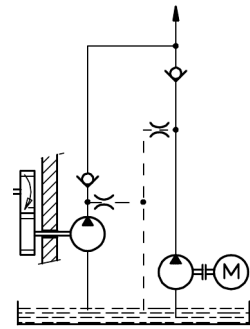

6.4.3 Pressure line

When designing the line, take the following points into consideration:

- Select the nominal width of the pressure line so that the maximum permissible pressures are not exceeded.
- If necessary, provide a vent nozzle to prevent suction problems.

6.4.4 Mounting Connection lines

- a) Clean all lines.
 - ⇒ Do not use cleaning wool.
 - ⇒ Pickle and flush welded pipes.
- b) Remove the protective plugs.
- c) Mount the lines.
 - ⇒ Comply with the manufacturer's information.
 - ⇒ Do not use any sealing materials such as hemp, Teflon tape or putty.



TIP

Position of the device connections: **Rotation and delivery direction** [▶ 12]

6.5 Change of the direction of rotation

A change in the direction of rotation is not possible.

7 Operation start-up

7.1 Safety instructions for start-up



⚠ DANGER

Hazardous fluids

Danger to life when handling hazardous fluids.

- a) Comply with the safety data sheets and regulations on handling the hazardous fluids.
- b) Collect and dispose of hazardous fluids so that no hazard is created for persons or the environment.



⚠ WARNING

Failure of load-carrying parts due to overload

Danger of injury from flying parts.

Danger of injury from spurting fluids.

- a) Do not operate the device against closed shut-off devices.
- b) Do not operate the device in the false direction of rotation.



⚠ CAUTION

Hot surfaces

Burn injury to skin if touched.

- a) Wear protective gloves at temperatures ≥ 48 °C.

7.2 Preparation

- a) Before starting the product, make sure that a sufficient quantity of the service fluid is extant to avoid dry running. This must be taken into account especially with large line volumes.
- b) Check all fastening screws on the product.
- c) Fill pump and the suction line with medium.

7.3 Further operation start-up

- a) Open existing shut-off elements upstream and downstream of the device.
 - b) Adjust pressure relief valves in the system installed for lowest opening pressure.
 - c) Allow the device start without or with a low pressure load (jog mode).
 - ⇒ Flow should have developed after 30 s at the latest.
 - d) Run the device for a few minutes depressurised or with low pressure.
 - e) Vent the system at the highest possible point.
 - f) Gradually increase the pressure load up to the desired operating pressure.
 - g) Operate the system for so long until the final operating state is achieved.
 - h) Check the operating data.
 - ⇒ **Maintenance table** [▶ 36]
 - i) Document the operating data of the initial start-up for later comparison.
 - j) Check the level of the operating medium in the system.
 - k) Check the filling level of the liquid seal (if existing).
 - l) Check the device for leaks.
 - m) Check all threaded connections for leaks and retighten if necessary.
-



TIP

In order to ensure a constant and reliable function of the product, an initial maintenance of the product is recommended after several hours warm-up time (max. 24 h). This allows faults to be detected at an early stage.

8 Removal

8.1 Safety instructions for removal



DANGER

Hazardous fluids

Danger to life when handling hazardous fluids.

- a) Comply with the safety data sheets and regulations on handling the hazardous fluids.
- b) Collect and dispose of hazardous fluids so that no hazard is created for persons or the environment.



DANGER

Rotating parts!

Danger of death due to body parts, hair or clothing getting trapped or entangled.

- a) Before all work, ensure that existing drives are voltage-free and pressure-free.
- b) Securely prevent restarting during all work.



WARNING

Unshielded gearwheels

Gearwheels can trap and crush fingers and hands.

- a) Do not engage gearwheels.



WARNING

Failure of load-carrying parts due to overload!

Danger of injury from flying parts.

Danger of injury from spurting fluids.

- a) Depressurise the device and all connection lines before doing any work.
- b) Securely prevent the restoration of pressure while working on the device.



CAUTION

Hot surfaces

Burns of the skin on contact.

- a) At temperatures $\geq 48^{\circ}\text{C}$ the product must be allowed to cool down first.

 **ATTENTION****Blocking of the product due to curing media**

Curing media can mechanically block the product and make it unusable.

- a) Clean the product immediately after operation with curing media.

8.2 Removal

- a) Depressurise and de-energize the system.
- b) Close existing shut-off elements upstream and downstream of the device.
- c) Open existing drain elements and loosen connection lines. Collect and dispose of discharging medium so that no hazard arises for persons or environment.
- d) Dismantle the device.
- e) Clean the device
- f) Close the device connections and lines to prevent dirt penetration.

**NOTICE**

The concrete procedure for cleaning depends on the media being used.

- a) See the safety data sheet of the media in use.

9 Maintenance

9.1 Important notes about explosion protection



⚠ DANGER

Hazardous fluids

Danger to life when handling hazardous fluids.

- a) Comply with the safety data sheets and regulations on handling the hazardous fluids.
- b) Collect and dispose of hazardous fluids so that no hazard is created for persons or the environment.



⚠ DANGER

Rotating parts!

Danger of death due to body parts, hair or clothing getting trapped or entangled.

- a) Before all work, ensure that existing drives are voltage-free and pressure-free.
- b) Securely prevent restarting during all work.



⚠ WARNING

Failure of load-carrying parts due to overload!

Danger of injury from flying parts.

Danger of injury from spurting fluids.

- a) Depressurise the device and all connection lines before doing any work.
- b) Securely prevent the restoration of pressure while working on the device.



⚠ CAUTION

Hot surfaces

Burns of the skin on contact.

- a) At temperatures $\geq 48^{\circ}\text{C}$ the product must be allowed to cool down first.

9.2 Maintenance work



TIP

Checking and documentation of the operating data

Regular checking and documentation of all operating data helps to detect faults at an early stage.

- Perform maintenance according to specification.
- Replace defective and worn components.
- If required, request spare parts lists and assembly drawings from the manufacturer.
- Document the type and scope of the maintenance work along with the operating data.
- Compare the operating data with the values of the first commissioning. Determine the cause in case of major non-compliances (> 10 %).
- Dispose of packing material and used parts in accordance with the local stipulations.



NOTICE

Protective equipment and notices

After maintenance and/or repair, reattach all protective devices and notices removed in the process to their original position.

9.3 Maintenance instructions

The following information provides recommendations for maintenance work and maintenance intervals for the product in use.

Depending on the actual loads occurring during operation, the type, scope and interval of the maintenance work may deviate from the recommendations. A mandatory maintenance plan must be drawn up by the installer/operating company.



TIP

In the course of preventive maintenance, it is advisable to replace wearing parts before the wear limit is reached.

With the appropriate expertise and sufficient equipment, the repair can also be carried out by the installer/operating company.

If necessary, request spare parts lists and assembly drawings from the manufacturer. Please consult the manufacturer for this purpose.



NOTICE

Warranty

Any warranty will be void if not executed properly.

9.4 Maintenance table

Maintenance table

		Firstly:after max. 24 h	Daily	3000 Operating hours	6000 Operating hours	As required	Additional information
9.4.1	Inspection: Discharge flow	2					
9.4.2	Inspection: Operating pressure	2					
9.4.3	Inspection: Media temperature	2					
9.4.4	Inspection: Device temperature	2					
9.4.5	Inspection: Add-on valve function (if existing)	2					
9.4.6	Inspection: Check the potential compensation (if existing)	2					
9.4.7	Inspection: Condition of operating fluid	2					
9.4.8	Audiometric monitoring: Unusual noise		1				
9.4.9	Cleaning		1				
9.4.10	Visual inspection: Leakages		1				
9.4.1	Inspection: Discharge flow			2			
9.4.2	Inspection: Operating pressure			2			
9.4.3	Inspection: Media temperature			2			
9.4.4	Inspection: Device temperature			2			
9.4.5	Inspection: Add-on valve function (if existing)			2			
9.4.6	Inspection: Check the potential compensation (if existing)			2			
9.4.7	Inspection: Condition of operating fluid			2			
9.4.11	Visual inspection: Condition gears				3		
9.4.12	Visual inspection: Condition of housing parts				3		
9.4.13	Visual inspection: Condition of plain bearings				3		
9.4.14	Visual inspection: Condition of shaft seal				3		
9.4.15	Visual inspection: Condition of outboard bearings				3		
9.4.16	Replacing: Outboard bearings					3	
9.4.18	Replacing: Shaft seal					3	
9.4.19	Replacing: Other seals					3	

1 - 0,1 h; 2 - 0,2 h; 3 - 0,75 h

9.4.1 Inspection: Discharge flow

The discharge flow is measured via the flow rate volume counters.

The values are displayed by the built-in controller in the electrical control system.

- If there is no discharge flow, check the individual components of the product.
- Comply with the product-specific data sheets/operating instructions.

9.4.2 Inspection: Operating pressure

The operating pressure is indicated by the pressure gauges

- If there is no operating pressure, check the individual components of the product
- Comply with the product-specific data sheets/operating instructions.

9.4.3 Inspection: Media temperature

The media temperature is measured through the temperature sensor.

The values are displayed by the built-in controller in the electrical control system.

- If the media temperature is too high or too low, check the product components.
- Comply with the product-specific data sheets/operating instructions.

9.4.4 Inspection: Device temperature

Measure the surface temperature in the area of the bearings.

9.4.5 Inspection: Add-on valve function (if existing)

Pressure relief valves must be actuated at regular intervals. This is the only way to ensure proper functioning.

9.4.6 Inspection: Check the potential compensation (if existing)

Check potential equalization for tight fit and function.

9.4.7 Inspection: Condition of operating fluid

Pay attention to colour (dark colouring), odour and milky turbidity.

- Replace operating fluid if necessary.

9.4.8 Audiometric monitoring: Unusual noise

In this case, attention must be paid to increased noise or uneven operation (pump unit).

- In case of unusual noises, check the individual components of the product, line attachments and the operating media for foam formation.
- Comply with the product-specific data sheets/operating instructions.

9.4.9 Cleaning

Remove dust deposits and dirt with a damp, clean cloth.

9.4.10 Visual inspection: Leakages

Care must be taken here to ensure that there is no leakage from the connections.

- In the event of leaks in the connections, the glands must be tightened and, if necessary, the seals replaced.

9.4.11 Visual inspection: Condition gears

Like shaft gear are wear items. In the event of excessive wear, the parts or the pump must be replaced.

Important control points are the mating surfaces of the shaft sealing ring and bearing bushes, the end faces of the shaft and pin wheels and the tooth flanks.

9.4.12 Visual inspection: Condition of housing parts

Important control points are the front sides of the wheel chamber.

9.4.13 Visual inspection: Condition of plain bearings

Like plain bearings are wear items. In the event of excessive wear, the parts or the pump must be replaced..

The wear limit of multi-layer plain bearings is reached when the bronze layer of the bearings is exposed to 50-70%.

The drive shaft and driven shaft are supported on the suction side under load in the bearings, so that the wear can be seen there first.

9.4.14 Visual inspection: Condition of shaft seal

Check on increased and impermissible temperature rises

- Small amounts of leakage, however, are indispensable for function.
- If there are excessive amounts of leakage, stop pump operation immediately.
Replace: Shaft seal.

9.4.15 Visual inspection: Condition of outboard bearings

Like outboard bearings are wear items.

The service life of the bearings depends primarily on the operating conditions.

The bearing should therefore be checked for damage after 4,000 hours at the latest. If the wear is unacceptable, the bearing must be replaced.

The beginning of wear or an imminent failure can become noticeable through increasing heating of the bearing, increased power consumption, imperfect running behavior or the development of noise.

9.4.16 Replacing: Outboard bearings

With corresponding expertise and sufficient equipment, the replacement can be carried out by the equipment builder/operator.

If required, request spare parts lists and assembly drawings from the manufacturer.

Use spare parts approved by the manufacturer only.

9.4.17 Replacing: Plain bearings (only by manufacturer)

The replacement is carried out only by the manufacturer.

Consult the manufacturer

9.4.18 Replacing: Shaft seal

With corresponding expertise and sufficient equipment, the replacement can be carried out by the equipment builder/operator.

If required, request spare parts lists and assembly drawings from the manufacturer.

Use spare parts approved by the manufacturer only.

9.4.19 Replacing: Other seals

With corresponding expertise and sufficient equipment, the replacement can be carried out by the equipment builder/operator.

If required, request spare parts lists and assembly drawings from the manufacturer.

Use spare parts approved by the manufacturer only.

10 Repairs

10.1 Safety instructions for repair



DANGER

Hazardous fluids

Danger to life when handling hazardous fluids.

- a) Comply with the safety data sheets and regulations on handling the hazardous fluids.
- b) Collect and dispose of hazardous fluids so that no hazard is created for persons or the environment.



DANGER

Rotating parts!

Danger of death due to body parts, hair or clothing getting trapped or entangled.

- a) Before all work, ensure that existing drives are voltage-free and pressure-free.
- b) Securely prevent restarting during all work.



WARNING

Failure of pressure bearing parts due to overload

Risk of injury from flying parts.

Risk of injury due to splashing fluids.

- a) Depressurize the system before all work.
- b) Securely prevent the pressure from being restored during work.



CAUTION

Hot surfaces

Burns of the skin on contact.

- a) At temperatures $\geq 48^{\circ}\text{C}$ the product must be allowed to cool down first.

10.2 General

The repairs covers:

1. Troubleshooting
Determination of damage, pinpointing and localisation of the damage cause.
2. Elimination of damage
Elimination of the primary causes and replacement or repair of defective components.
The repair is generally made by the manufacturer.

Repairs by manufacturer

Before returning the device, fill in the return notification form. The form can be filled in on-line and is available as a pdf file download.



NOTICE

Device contains hazardous material

If the device was operated with dangerous liquids, it must be cleaned before the return. If this should not be possible, the safety data sheet of the hazardous material is to be provided beforehand.

Repair by equipment builder/operator

If corresponding expertise and sufficient equipment is available, the equipment builder/operator can also make the repairs. Please consult the manufacturer about this.

- a) If required, request spare parts lists and assembly drawings from the manufacturer.
- b) Use spare parts approved by the manufacturer only
- c) Dispose of packing material and used parts in accordance with the local stipulations.



NOTICE

Warranty

Any warranty will be void if not executed properly.



NOTICE

Protective equipment and notices

After maintenance and/or repair, reattach all protective devices and notices removed in the process to their original position.

10.3 Detecting and eliminating failures

Fault	Potential causes	Possible measures
Increased noise		
Pump cavitation	Excessive negative pressure (not complete filling of the pump)	Check suction line design Use noise-optimised pump
	Suction line clogged	Clean the suction line
	Suction filter plugged or too small	Clean suction filter or use a larger filter
		Replace filter element
	Suction basket plugged or too small	Clean intake strainer or dimension larger
Fluid temperature too low	Adjust the temperature of medium	
Foaming or air in media	Pump does not suck	Check the oil level in the tank
		Check suction line
		Check the shaft seal
	Shaft seal defective	Replace seals
	Suction connection leaking	Tighten or replace the screw connections
		Replace seals
	System not vented	Vent the system
Return line ends above the fluid level	Extend return line	
Heavy foaming in the system, e.g. in gears	Use noise-optimised pump	
Mechanical vibrations	Incorrectly aligned and/or loose coupling	Correct the alignment of the coupling and secure the coupling halves
	Incorrectly and/or insufficient line fastening	Fixate lines with suitable fastening material (e.g. pipe clamps)
	Wobbling pressure relief valve	Increase valve opening pressure
	Not a noise-reducing setup	Use dampers
Pump does not suck		
	Dry run	Fill pump and the suction line with medium
	Minimum filling level in the reservoir tank undercut	Refill media
	Wrong direction of rotation	Correct the direction of rotation
	Throttled/closed shut-off element in the suction line	Open the shut-off element
	Suction line clogged	Clean the suction line
	The air in the suction line cannot be compressed in the pressure line	Reduce the start-up pressure
Vent the pressure line		

		Increase volume of the pressure line
	Speed of the pump is too low	Check the pump design
		During frequency inverter operation: Check the operation/line frequency
	Geodetic suction head too high	Check installation location
		Provide pre-filling pump
Insufficient pressure		
Insufficient pumping flow rate		
	Excessive negative pressure (not complete filling of the pump)	Check suction line design
	Too high media viscosity	Provide pre-filling pump
	Speed of the pump is too low	Check the pump design
		During frequency inverter operation: Check the operation/line frequency
	Throttled/closed shut-off element in the suction line	Open the shut-off element
	Suction line clogged	Clean the suction line
	Suction filter plugged or too small	Clean suction filter or use a larger filter
		Replace filter element
	Suction basket plugged or too small	Clean intake strainer or dimension larger
	Constant triggering of pressure relief valve (if existing)	Increase valve opening pressure
	Pump does not suck	Check the oil level in the tank
		Check suction line
		Check the shaft seal
	Wear	Replace the device
Excessive operating temperature		
	Cooling and heat dissipation insufficient	Increase the cooling capacity
	Not sufficient oil in the system	Check the container layout
	Excess fluid is being delivered into the supply tank via pressure relief valve under load	Check the pump design

Impermissible pump heating		
	Constant triggering of pressure relief valve (if existing)	Increase valve opening pressure
	Pressure too high in association with a media viscosity that is too low	Check the system design
	Speed too fast in connection with media viscosity that is too high	Check the system design
	Gland lid overtightened (for gland seal)	Unscrew gland lid and readjust leakage
	Suction pressure too high	Reduce the pressure
	Wear	Replace the device
Leakage		
Seal failure	Lack of maintenance	Comply with maintenance intervals Replace seals
	Mechanical damage	Replace seals
	Thermal overload	Check operating data Replace seals
	Pressure too high	Check operating data Replace seals
	Gas content in media too high	Check operating data Replace seals
	Corrosion/chemical degradation	Check material compatibility Replace seals
	Wrong direction of rotation	Correct the direction of rotation Replace seals
	Contaminated medium	Provide filtration Replace seals
	Gland lid not sufficiently tightened (for gland seal)	Retighten gland lid
	Loose screw connection	Tighten or replace the screw connections

Coupling		
Coupling wear	Alignment error	Correct the alignment of the coupling and secure the coupling halves
	Spider overloaded	Check operating data Use harder spider
Cam break	Spider wear Torque transmission due to metal contact	Adapt maintenance intervals Replace coupling
Premature spider wear	Alignment error	Correct the alignment of the coupling and secure the coupling halves Replace spider
	Spider failure due to chemical corrosion	Check material compatibility Replace spider
Motor protection switch tripped		
	Driving power too low	Check the drive design
	Motor incorrectly connected	Check motor connection
	Phase failure	Check feed/supply
	Current consumption too high	Check operating data
		Check direction of rotation
Motor circuit breaker incorrectly designed	Check operating data	
Consult the manufacturer in the event of unidentifiable faults		